

Installation Guide

Steritest® Symbio FLEX Pump



MilliporeSigma is the U.S. and Canada Life Science business of Merck KGaA, Darmstadt, Germany.

Contents

Introduction.....	5
System overview.....	5
Additional Features.....	5
About this Manual	6
Operator and Equipment Safety	6
Specifications and Operating Requirements	8
Overview of the FLEX Pump Assembly	10
Components of the Steritest® Symbio FLEX Pump	10
Steritest® Symbio FLEX Pump Configurations	12
In an Isolator: Low Integration Configuration on Round or Oval Cutouts	12
In an Isolator: High Integration Configuration on Round or Oval Cutouts	14
In an Isolator or a Vertical Laminar Flow Environment on Feet.....	16
Preparing to Install the Pump in the Isolator	18
Preparing the Isolator	18
For Low Integration Configuration.....	18
For High Integration Configuration.....	21
Installation Recommendations.....	24
Tools required.....	24
Tightening the screws	24
Precautions when Handling the Electronic Board	24
Unpacking the Equipment.....	25
Verifying that the Pump Functions Properly	27
Installing the Pump.....	31
Installing the Pump in an Isolator: Low Integration Configuration.....	31

Notice

The information in this document is subject to change without notice and should not be construed as a commitment by Millipore SAS, Molsheim, France. Millipore SAS assumes no responsibility for any errors that may appear in this document. This manual is believed to be complete and accurate at the time of publication. In no event shall Millipore SAS be liable for incidental or consequential damages in connection with or arising from the use of this manual.

Disassembling the Pump.....	31
Installing the Pump in the Isolator	42
Installing Using the Round Cutout.....	42
Installing Using the Oval Cutout	46
Reassembling the Pump Components	50
Installing the Communication Hub Under the Isolator: Low Integration	69
Installing the Communication Hub on the Side, High Version	69
Installing the Communication Hub on the Side, Low Version	71
Installing the Communication Hub below the Pump Housing	73
Installing the Pump in an Isolator: High Integration Configuration.....	74
Disassembling the Pump.....	74
Installing the Pump in the Isolator	76
Installing Using the Round Cutout.....	76
Installing Using the Oval Cutout	86
Tests After Installation	92
Installing the Communication Hub under the Isolator: High Integration.....	95
Installing the Communication Hub to the Left of the Pump	95
Installing the Communication Hub to the Right of the Pump	96
Installing the Communication Hub Centered under the Pump.....	97
Installing the Pump in an Isolator: on Feet.....	98
Using the Optional Carrying Handles	102
Installing the Pump in a Vertical Laminar Flow Environment: on Feet.....	103
Accessories and Replacement Parts.....	105
Symbols Referenced	107
Standard Product Warranty.....	108
Technical Assistance	109

Introduction

System overview

The Steritest® Symbio peristaltic pumps are used for sterility testing and are available in three versions: LFH, ISL, and FLEX. Combined with optional accessories, the pumps provide a wide range of installation possibilities for integration in all testing environments (laminar flow hood, biosafety cabinet, clean room, and isolator), including existing isolators without table rework. The Steritest® Symbio pumps have been designed to be used with Steritest® devices. Many types of sterile products can be tested with the Steritest® system, including:

- Large- and small-volume parenteral solutions in glass or plastic bottles, collapsible bags, ampoules, and vials
- Pre-filled syringes
- Lyophilized and other soluble products in ampoules or vials
- Antibiotics in ampoules or vials
- Medical devices
- Difficult-to-dissolve powders

The easy-load automatic pump head facilitates the Steritest® tubing placement in an isolator configuration and protects the user from the rotor.

A timer coupled with a rotor position compensation provides repeatability of small-volume sampling.

A pressure control system constantly monitors the pressure inside both canisters. An alarm signals pressure increases above the specifications. In regulation mode, the pump decreases the pump speed automatically until the pressure returns to normal.

The microorganisms present in the sample are captured on the Steritest® canisters microporous membrane. Appropriate medium is pumped into each canister separately to promote the growth of the captured organisms. The canisters are incubated and examined for contamination in accordance with the relevant pharmacopoeia.

Additional features

Tests can be run in either the Standard Mode, in which filtration parameters are chosen manually, or in the Test Method Mode, in which every step of the method appears on the screen with preloaded parameters for speed and time to ensure there is no deviation from the approved test protocol. The test methods are created with the Steritest® Symbio Software and transferred to the Steritest® Symbio pump through a network cable or with USB flash drive.

The pump and test method PC software can be used in ten languages (German, English, Spanish, French, Italian, Portuguese, Japanese, Simplified Chinese, Russian, and Turkish). The drain tray and bottle holder are ergonomically positioned around the pump head for easy access in limited-space environments.

A wide range of optional accessories are available to improve the sterility testing workflow:

- A footswitch with two operation modes
- A glass ampoule breaker
- A support rod extension for hanging sterile bags or the Steridilutor® vent chamber
- A syringe support to facilitate the handling of pre-filled syringes (with or without needles), and to provide an automatic rinsing function
- A liquid waste overflow sensor that signals an alarm on the pump screen when the waste container is nearly full
- A holder to attach the communication hub to one of the bench or hood feet
- A holder to attach the communication hub below the isolator table
- A tray that carries up to 5 Steritest® canisters and an optional rack to hold up to 4 carrying trays

NOTE

Go to www.sigmaaldrich.com to check the latest version of the Steritest® Symbio Pumps User Guide and get information about Steritest® Symbio Pump optional accessories.

About this Manual

This manual details the procedure for the installation of the Steritest® Symbio FLEX pump. All screen shots and drawings in this manual are examples and may vary depending on the pump version.

All dimensions indicated in the Steritest® Symbio pumps pictures are in millimeters (mm).

Operator and Equipment Safety

All employees who will operate and/or be near the Steritest® Symbio pump must comply with the following:

- Read and understand this user guide before starting the installation of the pump. Failure to follow installation and operating instructions could result in user injury or damage to the instrument.
- Read and understand all maintenance instructions in this user guide before performing maintenance on the pump. Failure to follow instructions could result in user injury or damage to the instrument.
- Any alteration of the pump from factory specification may cause unsafe conditions and will void the product warranty.
- Any attempt to use the pump in a manner not specified in this user guide may result in damage to the instrument, operator injury, and will void the product warranty.
- Do not attempt to repair the pump. Service should be performed by trained and authorized personnel only.
- Place the pump on a clean, flat, stable, horizontal surface, away from any source of excessive heat and close to an easily accessible, properly grounded power supply outlet.
- Do not expose the pump or the communication hub to liquid. If this happens, immediately switch off and disconnect the pump from the power outlet, and then decontaminate the pump and communication hub surfaces. For cleaning instructions, see the Steritest Symbio Pump User Guide.
- Never expose the equipment to extreme temperatures. Operating temperature must be between 15 °C and 40 °C (59 and 104 °F).
- Use only accessories and replacement parts designed for the pump. See Accessories and Replacement Parts. For additional accessories and replacement parts, see the Steritest Symbio Pumps User Guide. Using accessories not designed for the pump could result in user injury or damage to the instrument.
- The Steritest® Symbio Pump has been designed to be used with the Steritest® devices and accessories.
- When filtrating hazardous liquids, wear and use proper protective clothing and equipment for the handling and the disposal of the liquid to be filtrated.
- In case of skin contact with the filtrated liquid, refer to the safety datasheet of the filtrated liquid for first aid measures.
- Dispose the filtrated liquids according to local regulations.
- Do not use the Steritest® Symbio Pump to filtrate flammable products.
- Never touch the display or control panel with a sharp object.
- Before cleaning, shut down the the Steritest® Symbio Pump and switch off and disconnect the communication hub from the power source.
- The power supply must be protected by a fuse below the main connection.
- The electrical installation must comply with local standards.
- Use an electrical surge protector to prevent damage to the system.

Specifications and Operating Requirements

Parameter	Value/Range	
Dimensions and weight: as received without accessories	Width	326 mm (12.8 in.)
	Depth	355 mm (14.0 in.)
	Height	301 mm (11.8 in.)
	Weight	17.9 kg (39.5 lb)
	Pump head height	197 mm (7.8 in.)
Performance specifications	Rotation speed	up to 240 rpm
	Timer	from 0.5 to 999
Materials of construction	Pump housing	316L Stainless steel
	Pump housing flat seal	Silicone foam
	Pump housing screws	A2 Stainless steel
	Pump head protective cover housing	316L Stainless steel
	Pump head protective cover tubing guide	Polyphenylsulfone (PPSU)
	Pump head	316L Stainless steel
	Seal plate (closing system seal)	Polyoxymethylene (POM)
	Pump supports for drain tray and bottle holder	316L Stainless steel
	Screen pane/window	Toughened glass
	Screen housing	316L Stainless steel
	Screen housing seals	Ethylene propylene diene monomer (EPDM)
	Screen seal	Silicone
	Pump control panel/key pad	Polyester
	Rotary control knob	316L Stainless steel
	Rotary control knob seals	Ethylene propylene diene monomer (EPDM)
	Pump power inlet	Chrome-plated brass
	Pump feet	Polyvinyl chloride (PVC)
	Pump feet screws	A2 Stainless steel
	Drain tray	
	Drain tray container	Polyphenylsulfone (PPSU)
Drain tray support	316L Stainless steel	
Drain tray support seal	Ethylene propylene diene monomer (EPDM)	
Steritest® canisters carrying trays	Polyphenylsulfone (PPSU)	
Bottle holder		
Bottle holder support rod	316L Stainless steel	
Bottle holder basket	316L Stainless steel	
Bottle holder fastening system screw clip	Polyphenylsulfone (PPSU)	
Communication hub		
Housing	316L Stainless steel with epoxy paint	
Feet	Nylon and ethylene vinyl acetate (EVA)	
USB port	Nickel-plated brass and polybutylene terephthalate (PBT)	
Fuse holder	Thermoplastic+tin-plated copper alloy	
Ethernet port	Nickel-plated brass and polybutylene terephthalate (PBT)	
Communication ports (for footswitch, etc...)	Nickel-plated brass and polybutylene terephthalate (PBT)	
Power inlet	Polyamide 6.6 and nickel-plated steel	
Pump connection cable	Polyvinyl chloride (PVC)	
Pump connection cable grommet	Nickel-plated brass	
Pump connection cable connector	Chrome-plated brass	

Accessories for installation	Threaded stems	A2 stainless steel
	Flat seal	Silicone
Installation on Feet:		
	Feet for use in isolator	Polyphenylsulfone (PPSU)
	Carrying handles	316L stainless steel
High integration installation on round cutout:		
	Upper adapter ring	316L stainless steel
	Upper adapter ring screws	A2 stainless steel
	Lower adapter ring	316L stainless steel
	Lower adapter ring screws	A2 stainless steel
	Bottom plate	316L stainless steel
	Bottom plate screws	A2 stainless steel
High integration installation on oval cutout:		
	Adapter ring	316L stainless steel
	Adapter ring screws	A2 stainless steel
Electrical Specifications	Power supply voltage	100 to 240 Volt AC, 50/60 Hz
	Input to pump	24 Volt DC
	Power	Max 150 W
Operating Requirements	Ambient temperature	15 to 40 °C (59 to 104 °F)
	Relative humidity	<90%
	Altitude	<2000 meters (6561 feet)
	Filtration units	Compatible with all Steritest®, Sterisolutest®, Steridilutor® and liquid transfer kits
	Protection type (IEC 60529-2004)	IP64 for the pump
	Sound intensity	<70 dB
Regulatory information	<p>Millipore SAS certifies that the Steritest® Symbio Pump is designed and manufactured in application of:</p> <ul style="list-style-type: none"> • The following European Council directives: <ul style="list-style-type: none"> - Electromagnetic compatibility 2014/30/EU - Low voltage directive 2014/35/EU - Restriction of the use of certain Hazardous Substances in electrical equipment (RoHS) 2011/65/EU, supplemented by the new Delegated Directive 2015/863/EU. • The following standards: <ul style="list-style-type: none"> - IEC 61010-1 (Ed. 3) Safety requirements for electrical equipment for measurement, control and laboratory use—Part 1: General requirements - IEC 61326-1 (Ed. 2) Electrical equipment for measurement, control and laboratory use -EMC requirements—Part 1: General requirements. These standards include the national deviations as appropriate for the relevant countries: USA, Canada, Australia, Argentina, Brazil, China, India, Japan, Mexico, Russia, Saudi Arabia, South Africa, South Korea, Singapore • The Federal Communications Commission (FCC) standard and test method: <ul style="list-style-type: none"> - Standard: <ul style="list-style-type: none"> FCC part 15: 2014 Code of federal regulations Title 47—Telecommunication chapter 1—Federal Communication Commission. Part 15—Radio frequency devices Subpart B—Unintentional Radiators Limits and Methods of measurement of radio disturbance. - Test method: <ul style="list-style-type: none"> Section 15 .107—Information to the user Section 15 .109—Conducted limits • The European Union Directive 2012/19/EU on Waste Electrical and Electronic Equipment (WEEE) • UK Statutory Instruments and their amendments: <ul style="list-style-type: none"> - 2016 No 1101 The Electrical Equipment Safety Regulations 2016 - 2016 No 1091 The Electromagnetic Compatibility Regulations 2016 - 2017 No.1206 The Radio Equipment Regulations 2017 - 2012 No 3032 The Restriction of the Use of Hazardous Substances in Electrical and Electronic Equipment Regulations 2012 	

Overview of the FLEX Pump Assembly

Components of the Steritest® Symbio FLEX Pump

The Steritest® Symbio FLEX pump assembly consists of:

- The pump, including:
- A control panel on the front
- An adjustable color display at the back
- A pump head located below a protective cover on the top
- A bottle holder (mounted on the left side of the pump)
- A drain tray (mounted on the right side of the pump)
- A communication hub equipped with the cable dedicated to connect it to the pump
- A power cord

Some additional accessories are also delivered with the pump:

- A network cable (for connection of the pump to a network or directly to a computer) for the transfer of test methods from a computer to the pump
- A USB flash drive for the transfer of test methods from a computer to the pump
- Silicone drain tubing for the liquid disposal
- 2 threaded stems
- A flat seal
- 2 Steritest® canisters carrying trays (Coming soon. Check our website for availability.)

WARNING

Do not discard the Steritest® canisters carrying trays. Deliver them to the final user of the

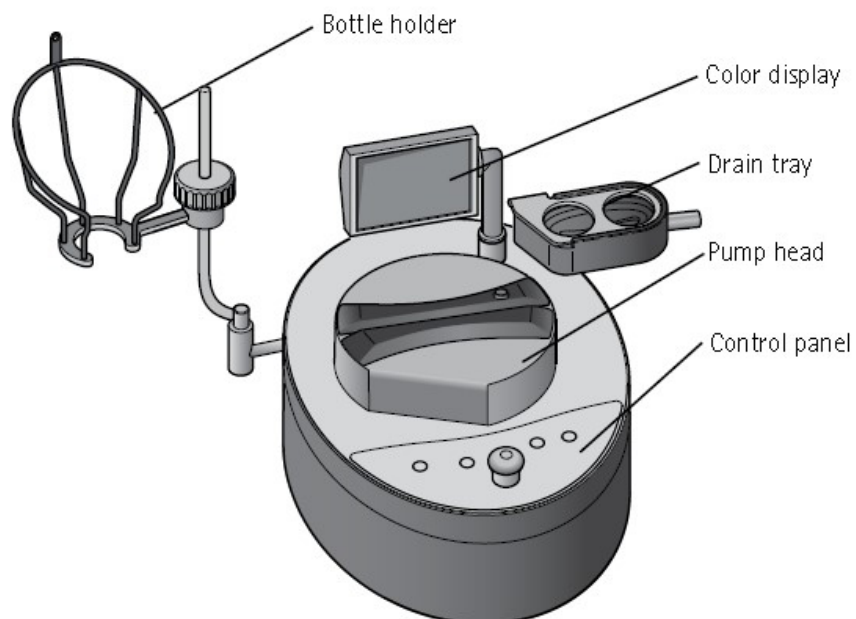

Communication hub—front view:

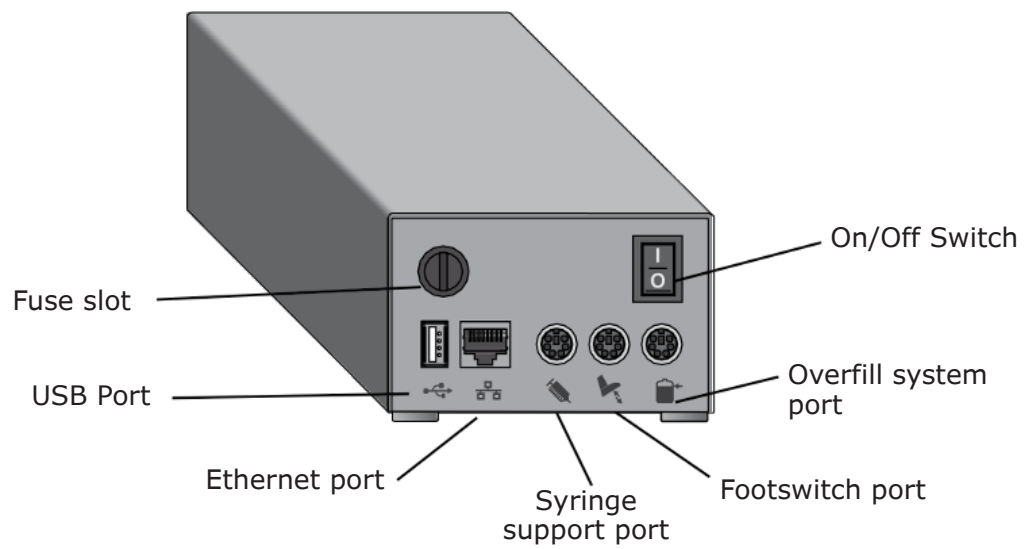

Communication hub—rear view:

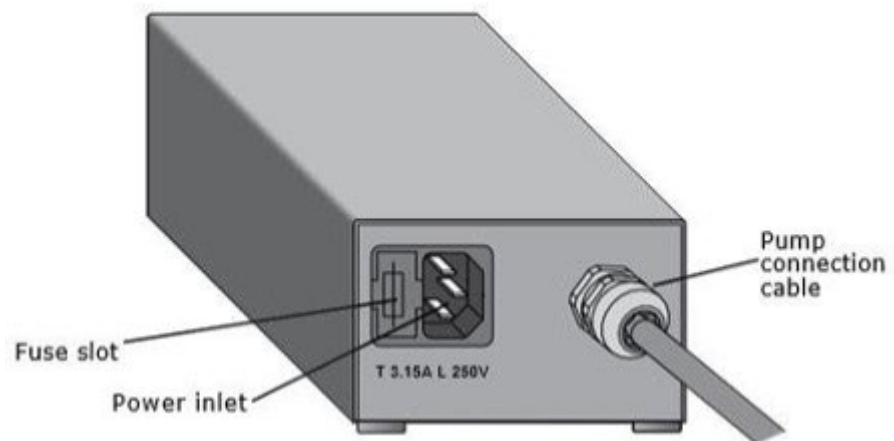

Steritest® Symbio FLEX Pump Configurations

NOTE

Dimensions are in millimeters

The Steritest® Symbio FLEX Pump can be used in multiple configurations:

In an Isolator: Low Integration Configuration on Round or Oval Cutouts

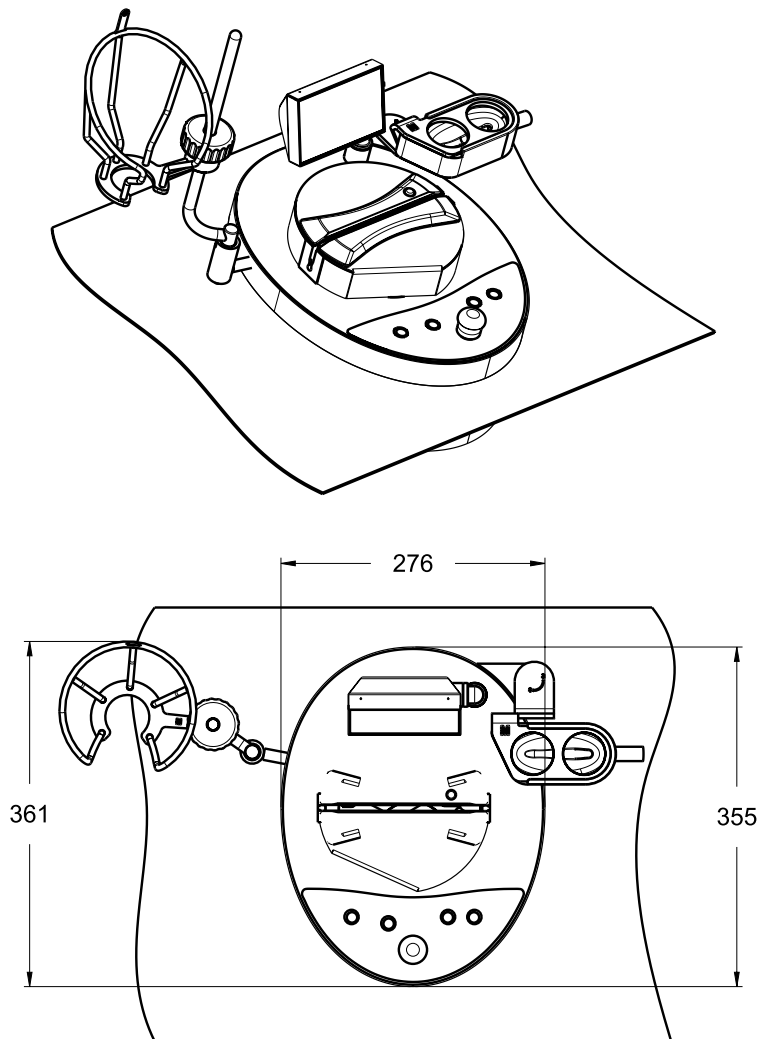

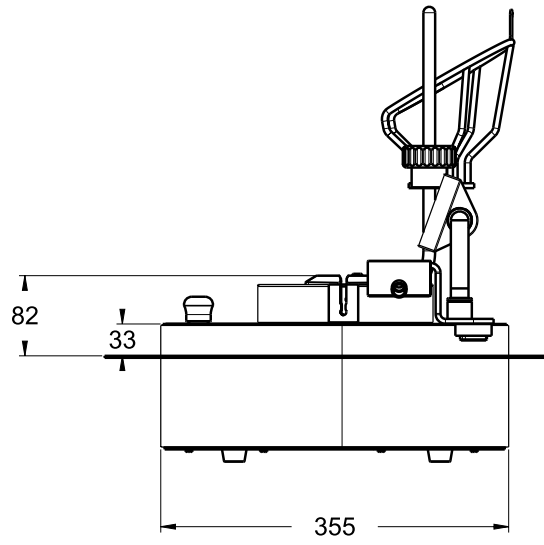
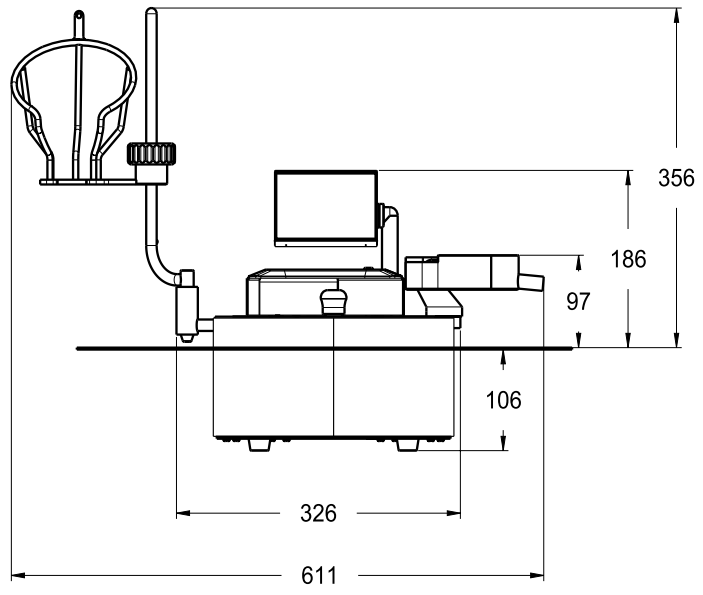

In an Isolator: High Integration Configuration on Round or Oval Cutouts

To install the pump in an isolator in high integration configuration, a special integration kit (sold separately) is required (see Installing the Pump in an Isolator: High Integration Configuration). There are two integration kits, one for a round cutout and one for an oval cutout. The following drawings below show the dimensions of the pump when installed in an isolator equipped with the standard round cutout.

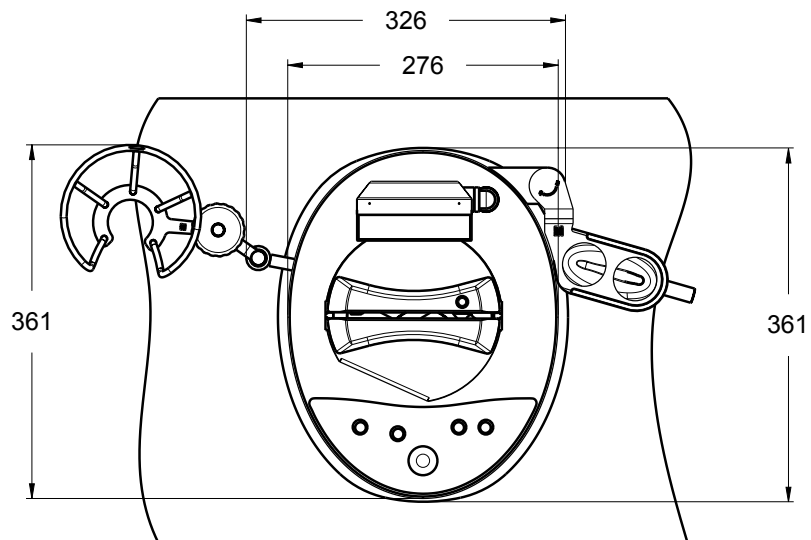
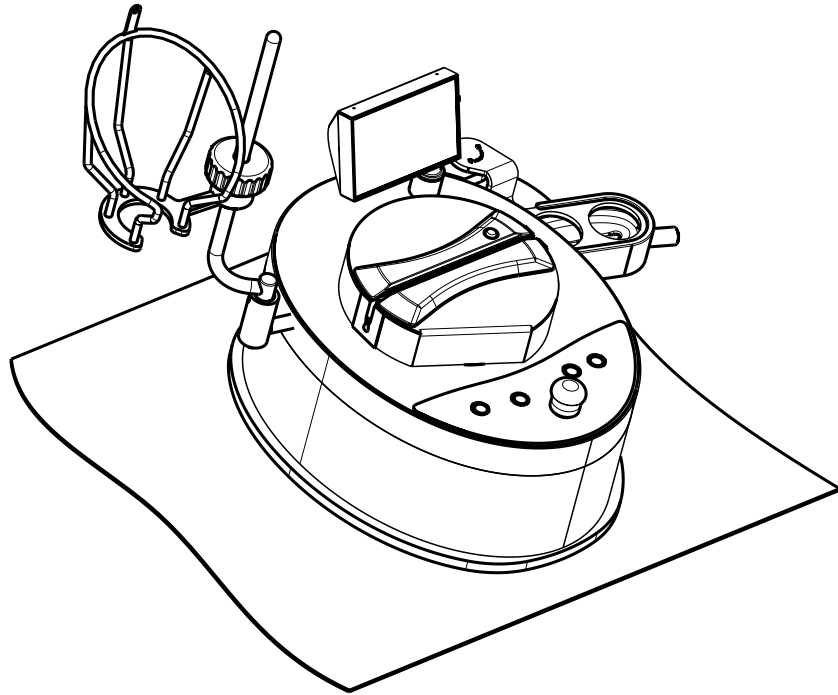

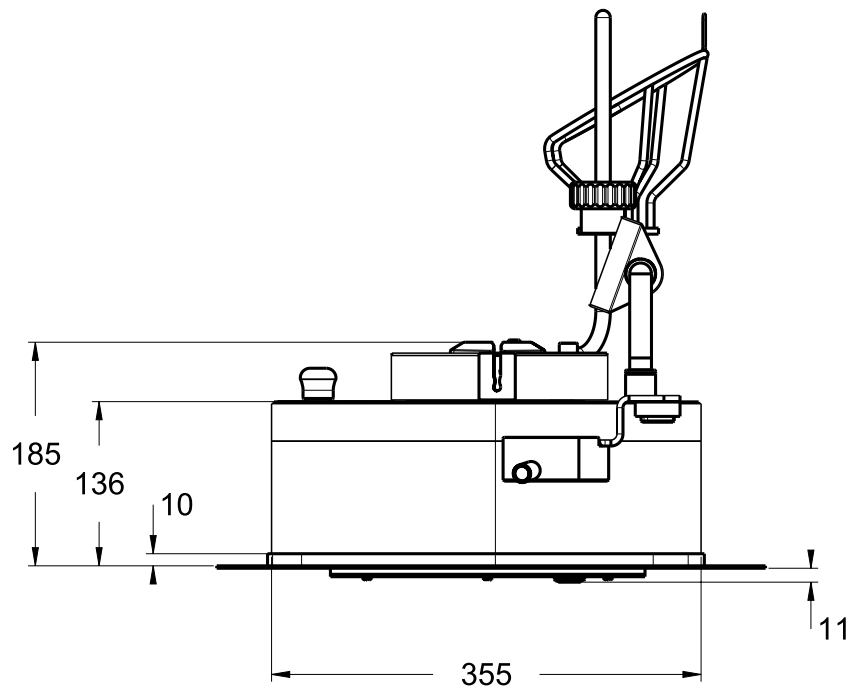
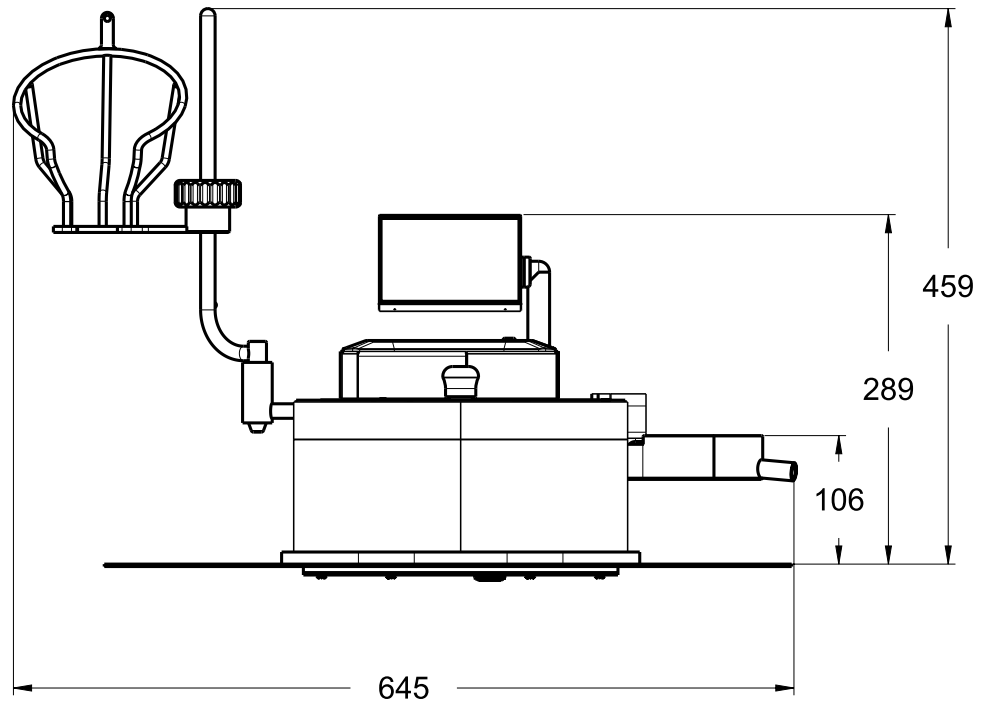

In an Isolator or a Vertical Laminar Flow Environment on Feet

The Steritest® Symbio FLEX pump can be used on feet in an isolator, or in a vertical laminar flow environment.

To install the pump on feet, some optional accessories may be necessary (see Installing the Pump in an Isolator: On feet or Installing the Pump in a Laminar Flow Hood: On feet).

The following drawings show the dimensions of the pump when installed on special feet for use in an isolator.

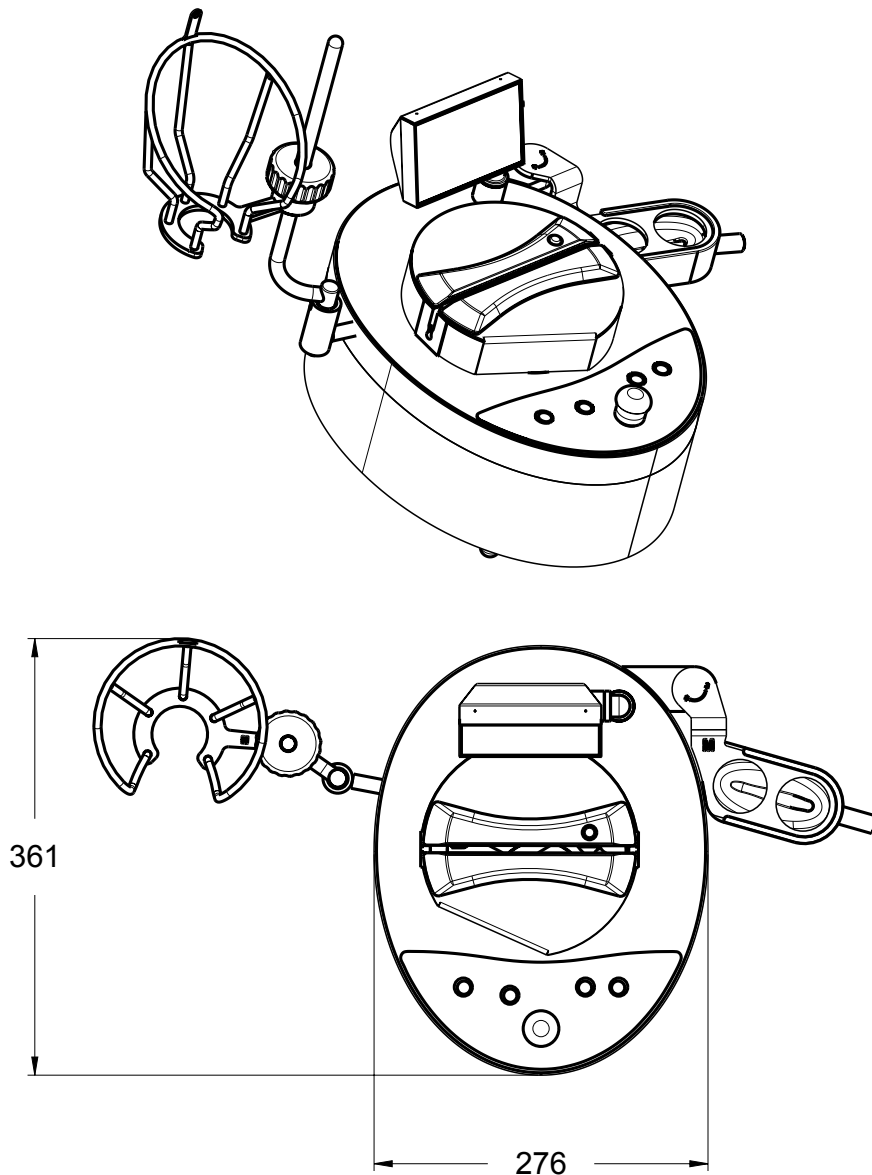

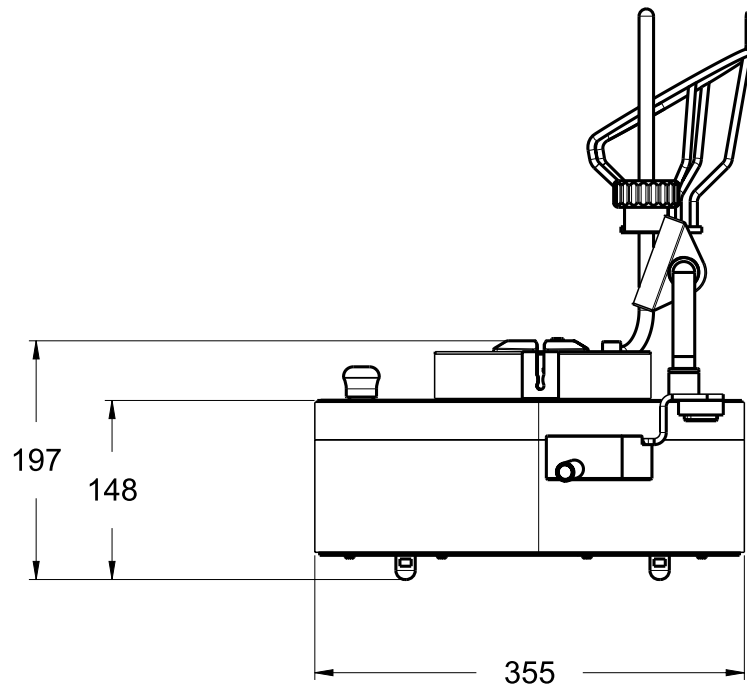
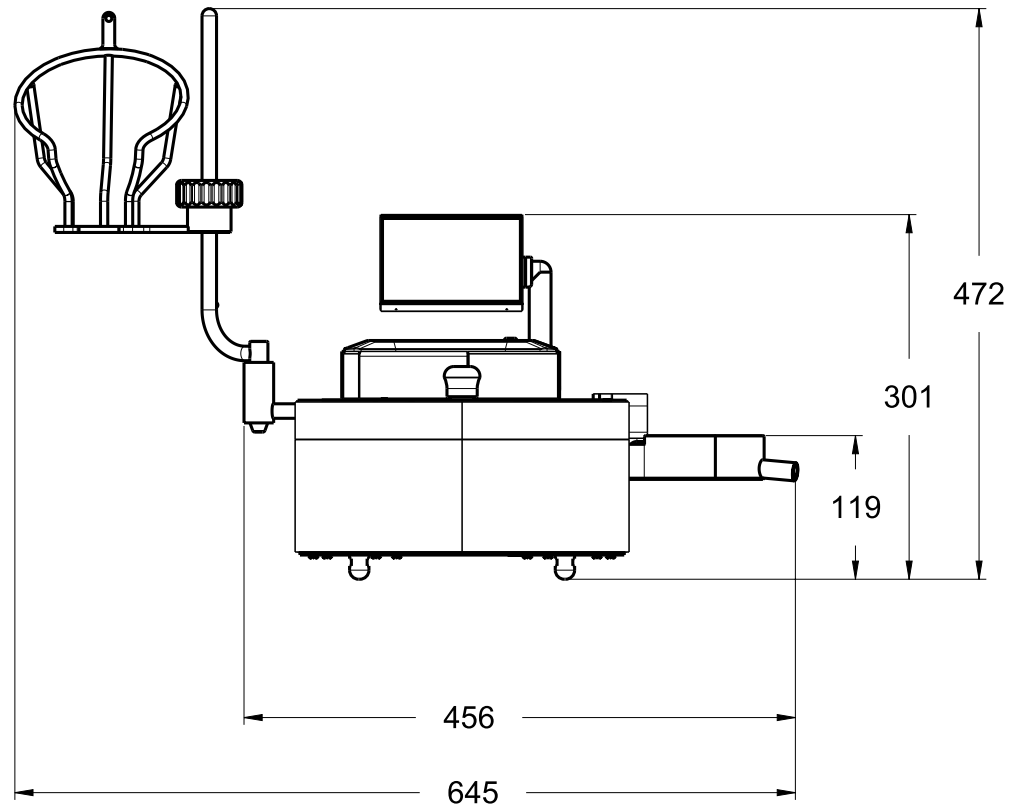

The standard feet that are delivered with the pump are 12.5 mm (0.49 in.) high.
 The special feet that must be installed on the pump for use in an isolator are 20 mm (0.79 in.) high.

Preparing to Install the Pump in the Isolator

Preparing the Isolator

To install the Steritest® Symbio FLEX pump in an isolator, a specific cutout must be made in the table. Depending on the integration configuration (low or high), the position of this cutout in relation to the drain and the isolator front wall is different.

For Low Integration Configuration

The cutout details and the recommended position of the drain in relation to the cutout are indicated in the following drawing.

NOTE

The e-drawing file (.dxf) for this cutout is available at www.sigmaldrich.com.

The Steritest® Symbio FLEX pump is compatible with the cutout for the Steritest® Integral Pump, the Steritest® Equinox Isolator TQNXISL01 pump, and the Steritest® Equinox Isofit pump. If a Steritest® Symbio FLEX pump replaces any of these pumps, no modification of the isolator table cutout is required.

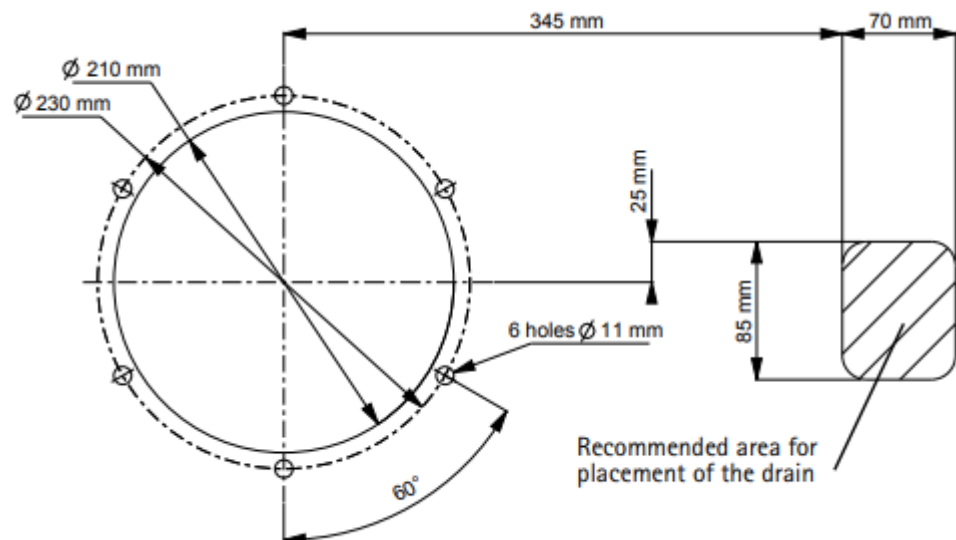

To ensure good flow of the liquid to the drain, the isolator table should be equipped with an elbow piece (oriented to the drain tray) to which the drain tubing can be connected.

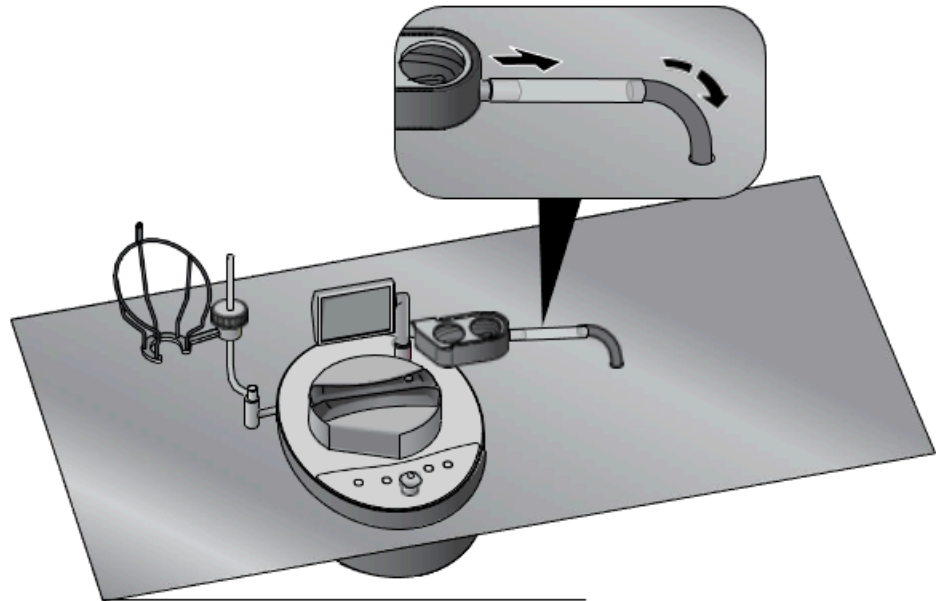

The height of the elbow piece should not exceed 50 mm to ensure that the drain tray is higher than this elbow piece.

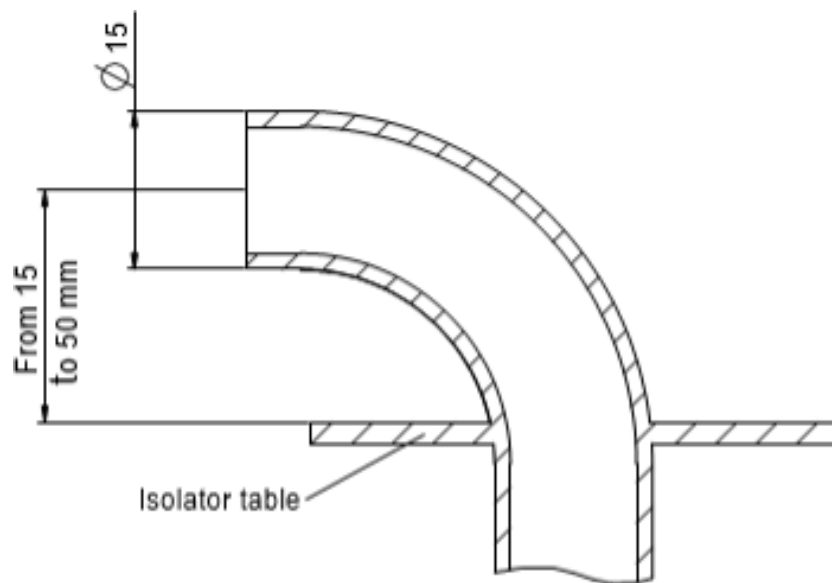

The position of the cutout on the isolator table must be defined according to the dimensions and contents of the isolator in order to avoid any interference and improve ergonomics.

The following drawing shows the size of the pump upper part (the part that is on the top of the isolator table), with its accessories, in relation to the cutout.

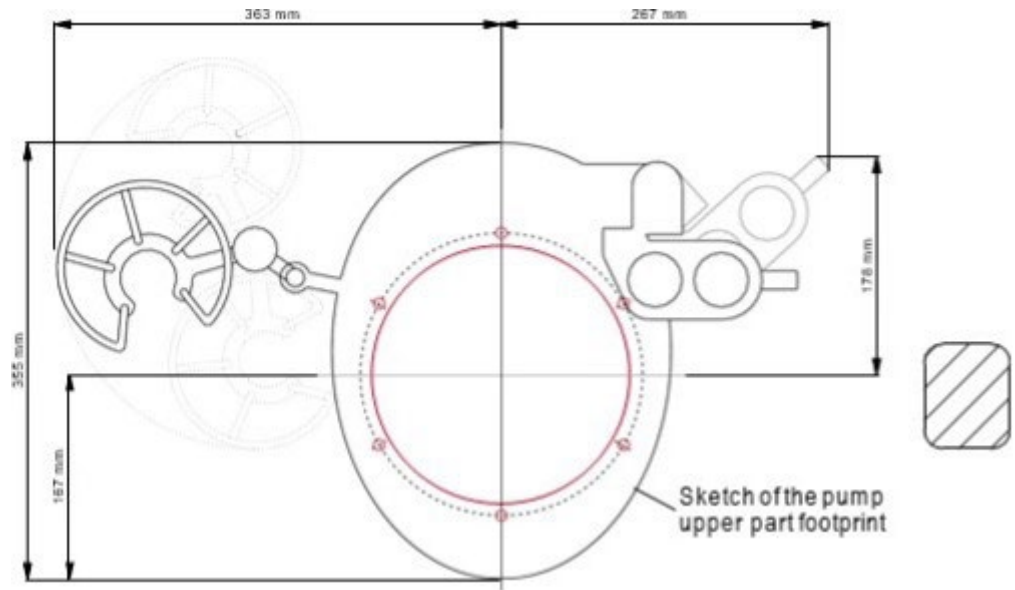

The following drawing shows the size of the pump bottom part (the part that is under the isolator table), with the drain position recommendation, in relation to the cutout. The height of the pump bottom part under the isolator table is 106 mm.

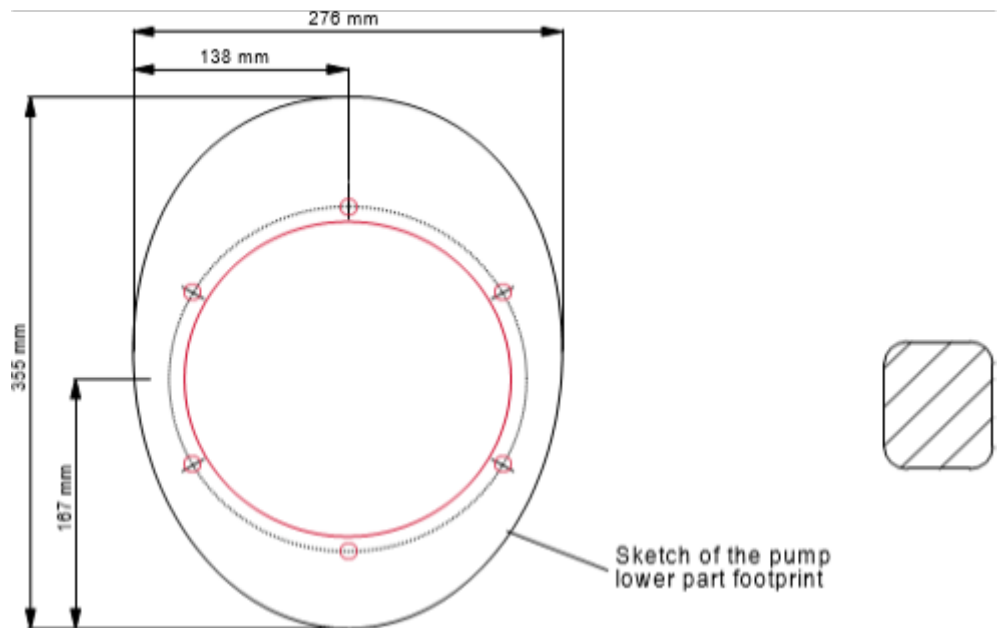

NOTE

The communication hub is not represented on this drawing. It can be attached in multiple positions under the isolator table using the optional Steritest® Symbio communication hub holder for isolators (see Installing the Communication Hub Under the Isolator: Low Integration Configuration and Accessories and Replacement Parts). It can also be fixed to one of the isolator feet, using the optional communication hub holder for hoods (see Accessories and Replacement Parts.)

To ensure good working ergonomics, it is recommended that the center of the cutout be positioned between 278 and 303 mm from the isolator wall.

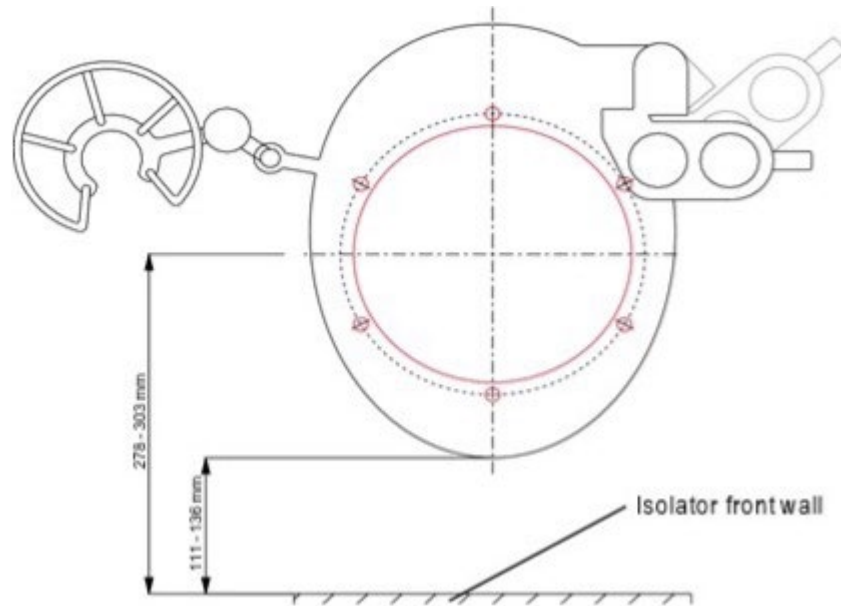

For High Integration Configuration

The cutout details and the recommended position of the drain in relation to the cutout are indicated in the following drawing.

NOTE

The e-drawing file (.dxf) for this cutout is available at www.sigmaldrich.com.

The Steritest® Symbio FLEX pump is compatible with the cutout for the Steritest® Integral Pump, the Steritest® Equinox Isolator TQNXISL01 pump, and the Steritest® Equinox Isofit pump. If a Steritest® Symbio FLEX pump replaces any of these pumps, no modification of the isolator table cutout is required.

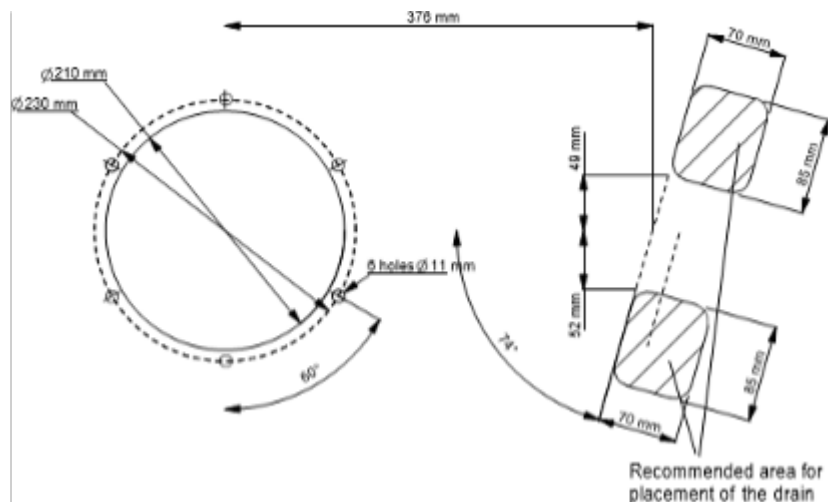

To ensure good flow of the liquid to the drain, the isolator table should be equipped with an elbow piece (oriented to the drain tray) to which the drain tubing can be connected.

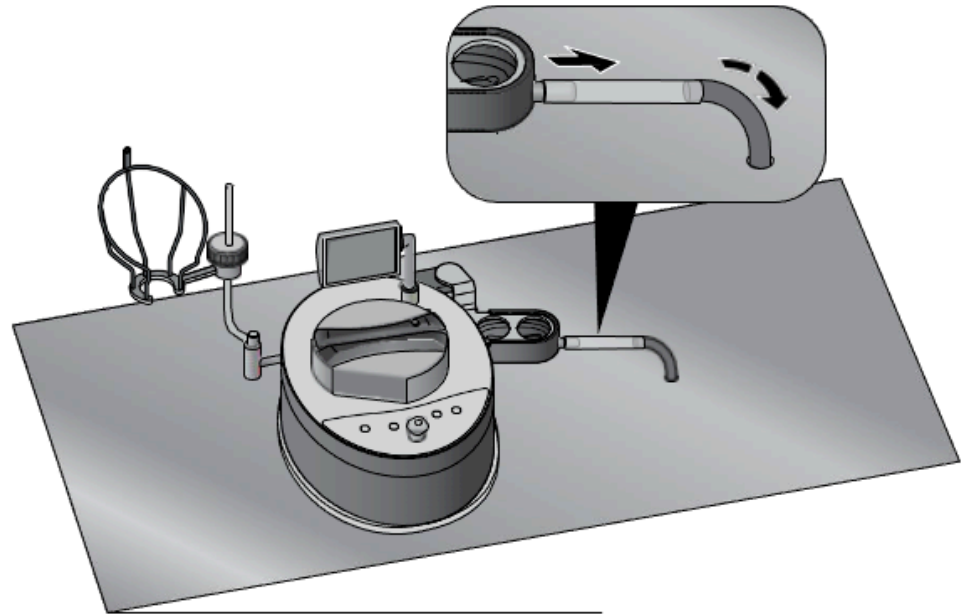

The height of the elbow piece should not exceed 50 mm to ensure that the drain tray is higher than this elbow piece.

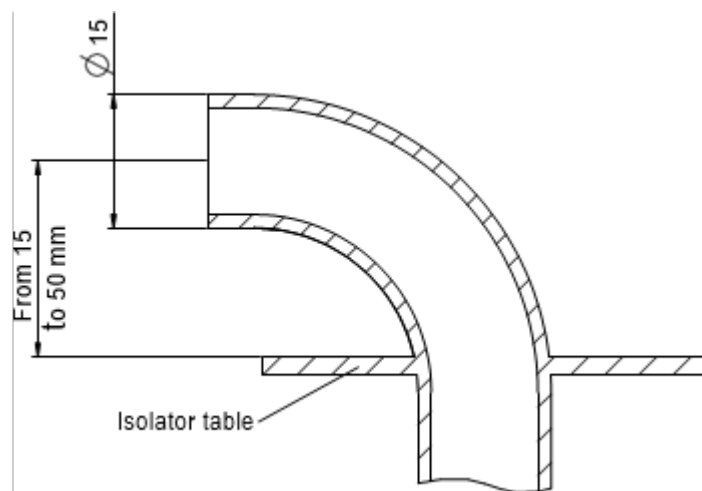

The position of the cutout on the isolator table must be defined according to the dimensions and contents of the isolator in order to avoid any interference and improve ergonomics.

The following drawing shows the size of the pump, with its accessories, in relation to the cutout.

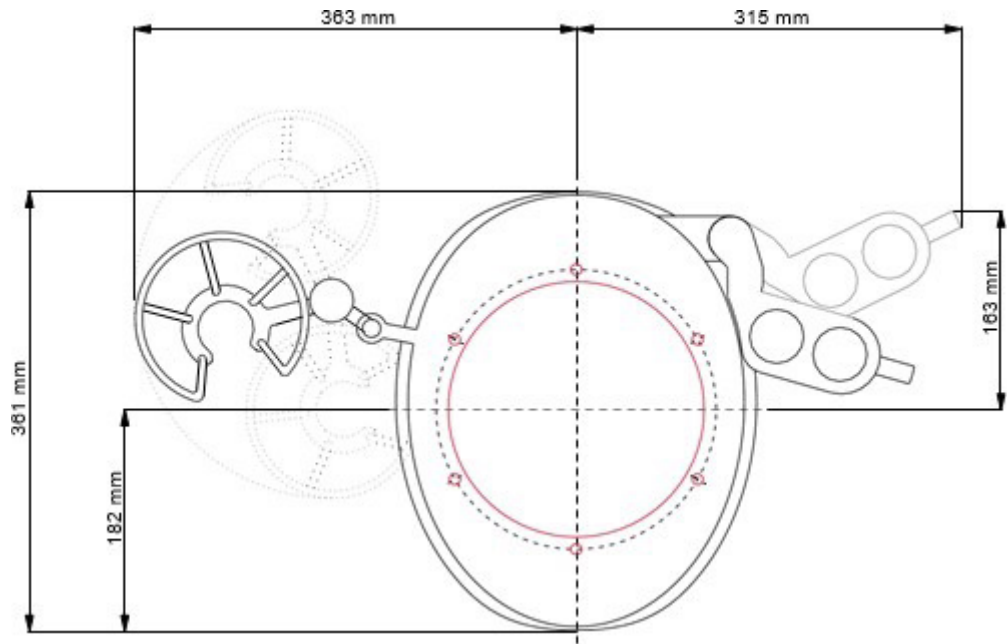

NOTE

The communication hub is not represented on this drawing. It can be attached in multiple positions under the isolator table using the optional Steritest® Symbio communication hub holder for isolators (see Installing the Communication Hub under the Isolator: High Integration Configuration and Accessories and Replacement Parts). It can also be fixed to one of the isolator feet, using the optional communication hub holder for hoods (see Accessories and Replacement Parts.) It can also be fixed to one of the isolator feet, using the optional communication hub holder for hoods (see Accessories and Replacement Parts.)

To ensure good working ergonomics, it is recommended that the center of the cutout be positioned between 290 and 315 mm from the isolator wall.

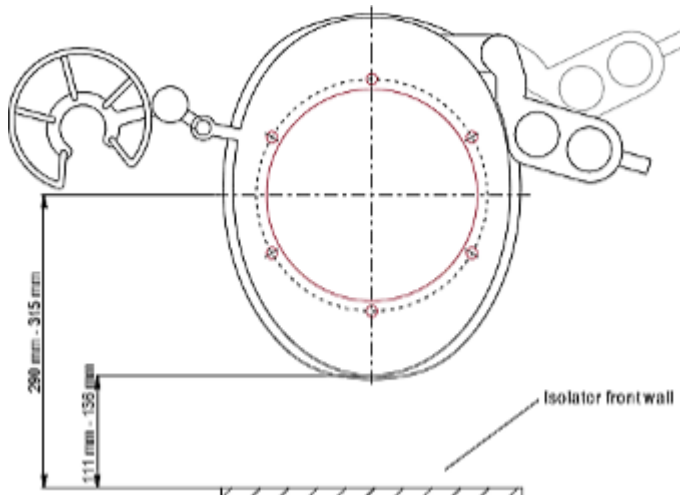

Installation Recommendations

Warning:

The pump must be opened to proceed to the installation. This operation does not void the warranty. However, to preserve this warranty, it is mandatory to execute the short test cycles (before and after installation) described in this installation guide.

Use the Steritest® Symbio Pumps Isolator Installation Checklist (PF17360) to document the proper execution of the installation steps and test cycles.

(Download the checklist at www.sigmaaldrich.com)

Deliver this document to the end user of the pump.

Tools Required

The following tools are required for the installation of the pump:

- A T20 star screwdriver
- A #3 hex key
- A #5 hex key
- A #6 hex key (used only for high integration installation of the pump on a round cutout)
- A #4 hex key (used only for the installation of the optional carrying handles, which can be used when the pump is installed on feet in a laminar flow hood or in an isolator)
- A #13 wrench (used only for the installation of the special feet for use in an isolator.)

Tightening the Screws

To ensure the tightness of the system, each time screws are installed throughout the installation procedure, tighten them evenly and equally.

Precautions when Handling the Electronic Board



The electronic board is electrostatic sensitive. Observe precautions for handling.

Unpacking the Equipment

The Steritest® Symbio FLEX Pump is delivered in two boxes that are strapped together.

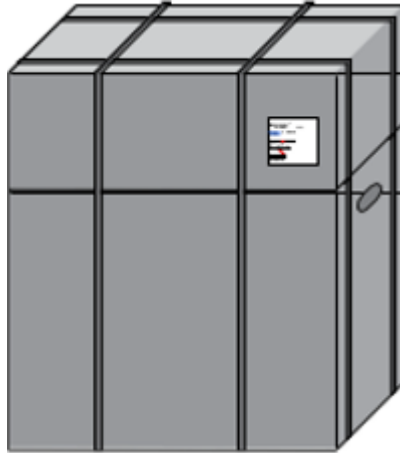

The larger box contains:

- The Steritest® Symbio FLEX Pump
- The communication hub
- The pump Certificate of Quality
- Operator and equipment safety instructions (in ten languages)
- 2 Steritest® canisters carrying trays (Coming soon. Check our website for availability.)
- User quick guide for the Steritest® canisters carrying trays and rack

WARNING

Do not discard the Steritest® canisters carrying trays. Deliver them to the final user of the pump.

The smaller box contains the pump accessories:

- A bottle holder (support rod and basket, not assembled)
- A drain tray (support and container, not assembled)
- 2 threaded stems
- A flat seal
- Silicone drain tubing (1.5 meter)
- A network cable
- A power cord
- A USB flash drive

- Quick guides (in German, English, Spanish, French, Italian, Portuguese, Japanese, Simplified Chinese, Russian, and Turkish):
 - Steritest® Symbio Pump Startup Quick Guide
 - Steritest® Symbio Pump User Interface Quick Guide
 - Steritest® Symbio Software Quick Guide

To unpack the boxes:

1. Using the carrying handles on the larger box, place the package on a flat, stable, and horizontal surface.
2. Cut the plastic straps to separate the two boxes.
3. Put the smaller box aside.
4. Open the larger box.
5. Retrieve the pump Certificate of Quality and the safety instructions.
6. Remove the communication hub from the top wedging system.
7. Remove the top wedging system.
8. Place hands below the pump, take it out of the box, and place it on a flat and stable surface.
9. Remove the 2 Steritest® canisters carrying trays and deliver them to the user of the pump. Open the smaller box that contains the accessories.

NOTE

Store all packaging materials in a dry area for future use. The pump and the communication hub must be packaged in this certified packaging if shipment back to a service center is required. The pump and the communication hub can also be packaged in the Steritest® Symbio pumps shipment case (see Accessories and Replacement Parts).

The top wedging system is also required for use in pump installation (see Installing the Pump).

10. Open the smaller box that contains the accessories.
11. Remove the power cord from the smaller box.

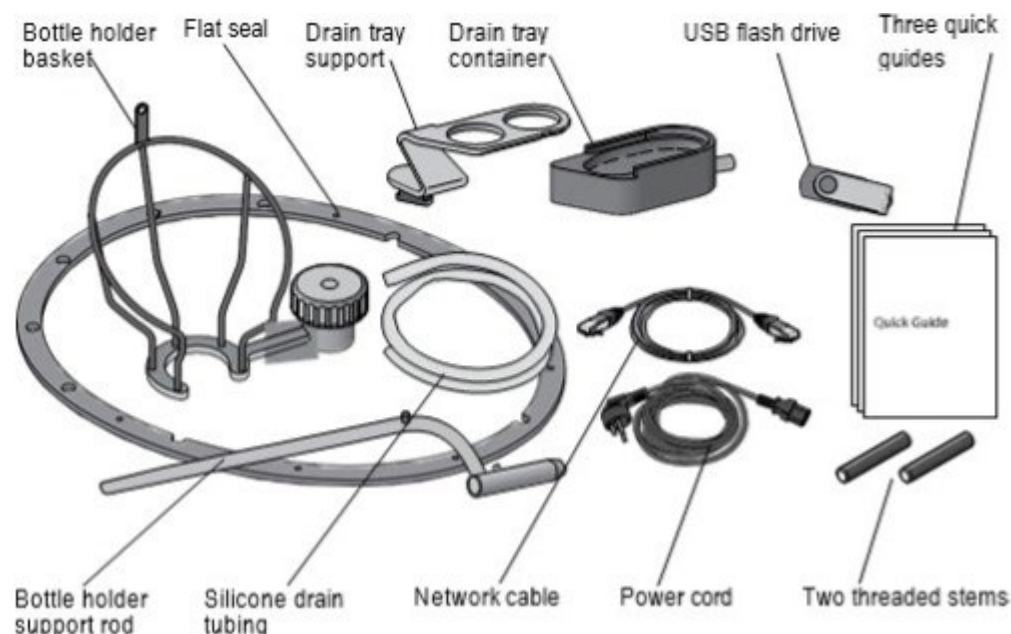

NOTE

The Steritest® Symbio Pumps User Guide, this installation guide for the FLEX pump version, and the Steritest® Symbio Software User Guide are available at www.sigmaaldrich.com.

Verifying that the Pump Functions Properly

Before installing the pump, verify that it is functioning properly.

1. Place the pump on its side and connect the communication hub pump connection cord to the pump power inlet. Return the pump to the upright position.

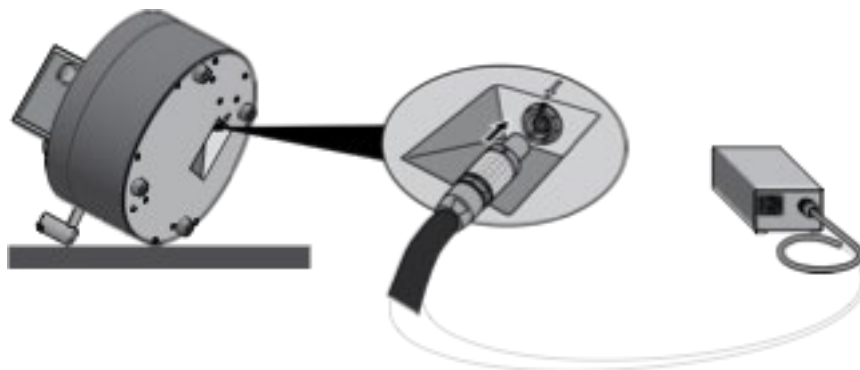

2. Connect the communication hub to the power source using the power cord delivered with the pump.
3. Switch on the communication hub by pressing the on/off switch (position I).

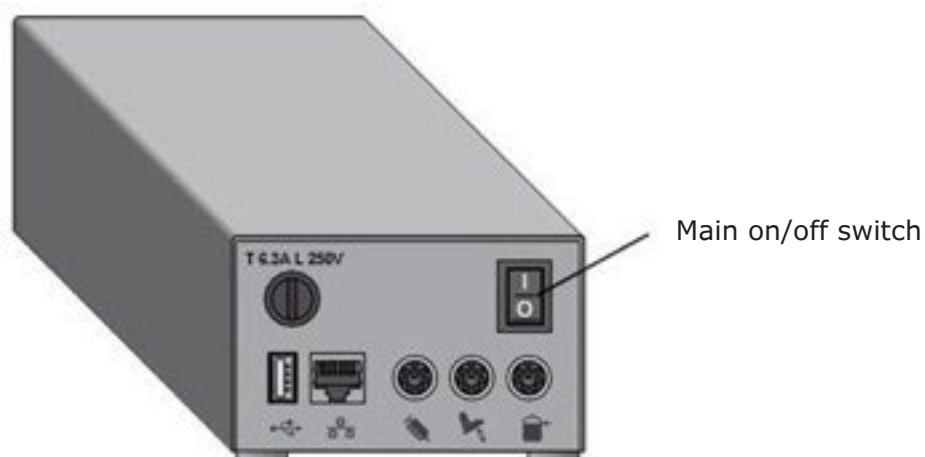

4. Simultaneously press and hold the pump on/off  and the open/close  buttons. The welcome screen displays



5. After a few seconds, the following screen displays:



6. When the autotest is complete, the following screen displays. A ✓ symbol in a check box indicates that an accessory or data source is connected to the communication hub.

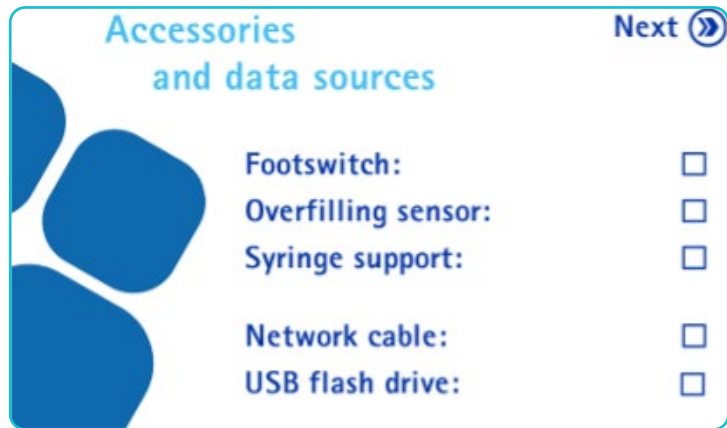

7. Press the » button. The installation menu displays.

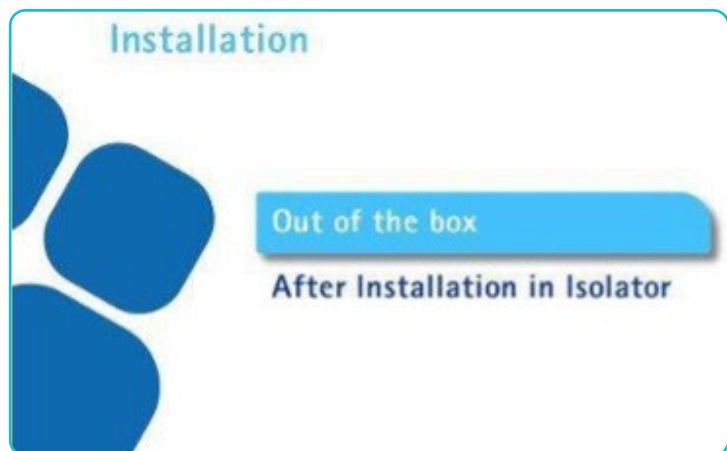

8. Press the control knob to select Out of the box. The Out of the box screen displays.

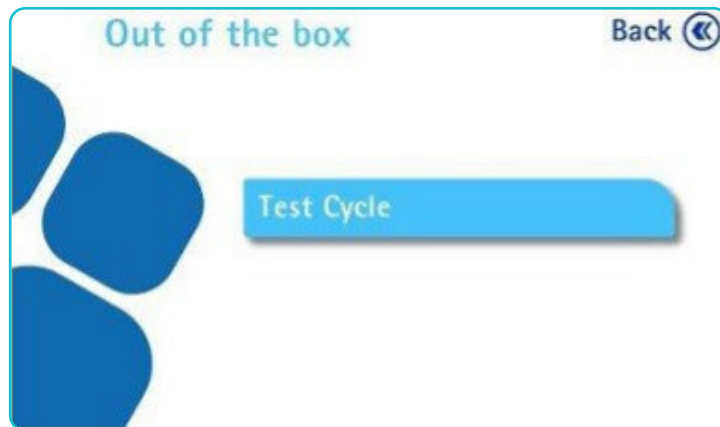

9. Press the control knob to begin the test cycle. Only one cycle will be performed.



10. After pump head closes, the pump starts automatically, and 1 test cycle is performed.



11. When the Test Cycle completes with no error, the following screen displays.

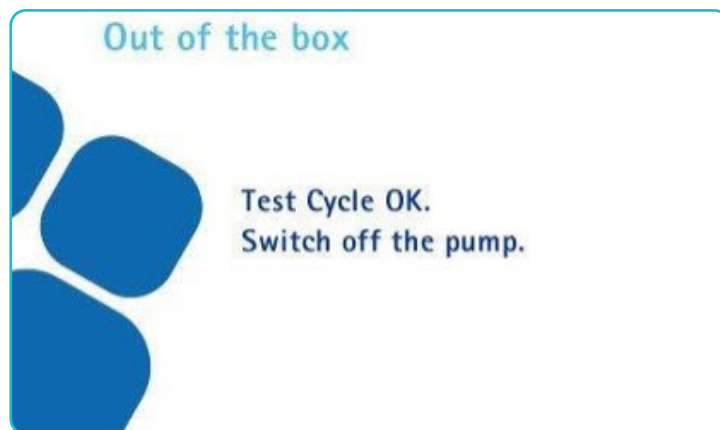

12. Switch off the communication hub by pressing the on/off switch (position O). The Shutdown screen displays.



13. Disconnect the communication hub pump connection cord from the pump power inlet.
14. Proceed to the installation of the pump (see Installing the Pump).

Installing the Pump

Four installation configurations are possible:

- In an isolator: low integration configuration on a round or oval cutout
- In an isolator: high integration configuration on a round or oval cutout
- In an isolator: on feet
- In a laminar flow hood: on feet

Installing the Pump in an Isolator: Low Integration Configuration

NOTE

This procedure applies to isolator tables that are up to 7 mm thick. For thicker isolator tables, an adaptation kit is required. Contact our sales representative for more information.

Disassembling the Pump

1. Verify that the pump functions properly and verify that the pump head is in its closed position (see Verifying that the Pump Functions Properly).
2. Retrieve the top wedging system from the packaging materials and place it on a flat, stable horizontal surface with the face in which the communication hub was located against the surface.
3. Turn the pump display to its transportation position (horizontal).
4. Turn the pump upside-down and place it on the top wedging system.

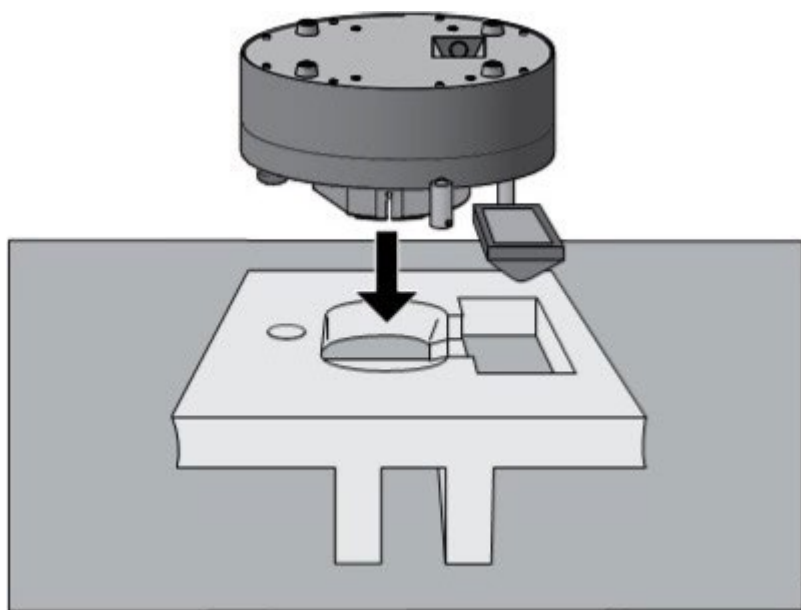

5. Locate the 8 screws that secure the pump bottom plate to the pump housing.

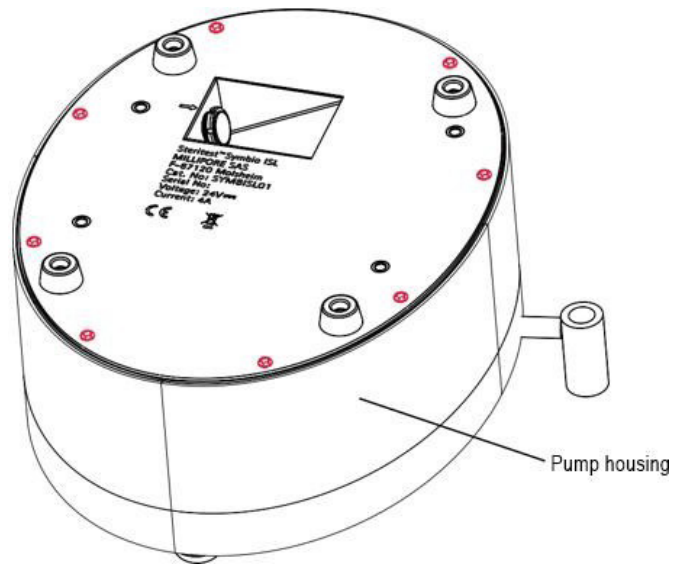

6. Use a T20 star screwdriver to remove the 8 screws.

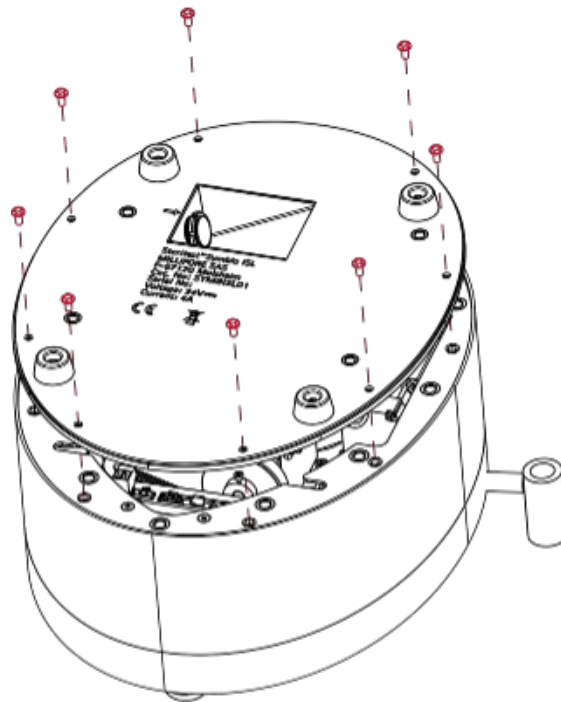

NOTE

The cable that connects the pump power inlet to the electronic board is attached to the pump bottom plate. It must be disconnected in order to remove the pump bottom plate.

7. Gently lift the pump bottom plate off the pump (1), disconnect the cable (2), and completely remove the bottom plate (3).

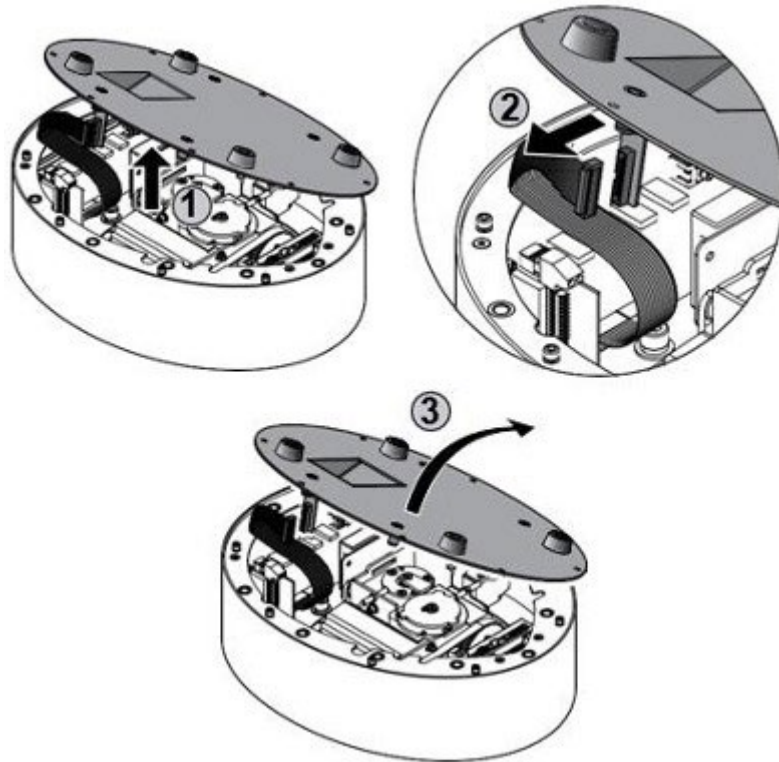

8. Locate the main components of the pump and all the cables from the main electronic board (located at the rear of the pump) and the cables from the rotor motor reducer driver (located at the front of the pump).

NOTE

In the following drawings, the cables are not represented in order to simplify the drawings.

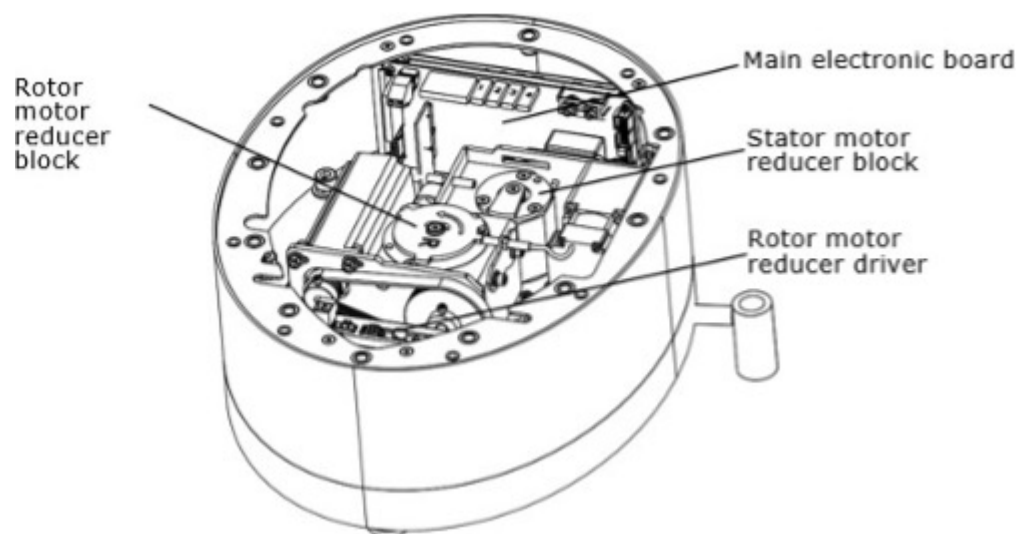

Electronic board simplified view:

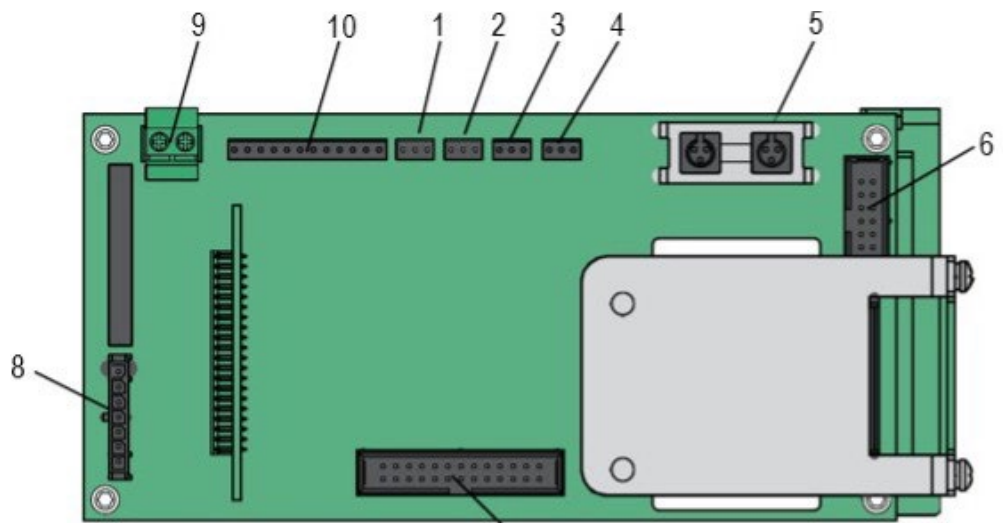

Rotor motor reducer driver view:

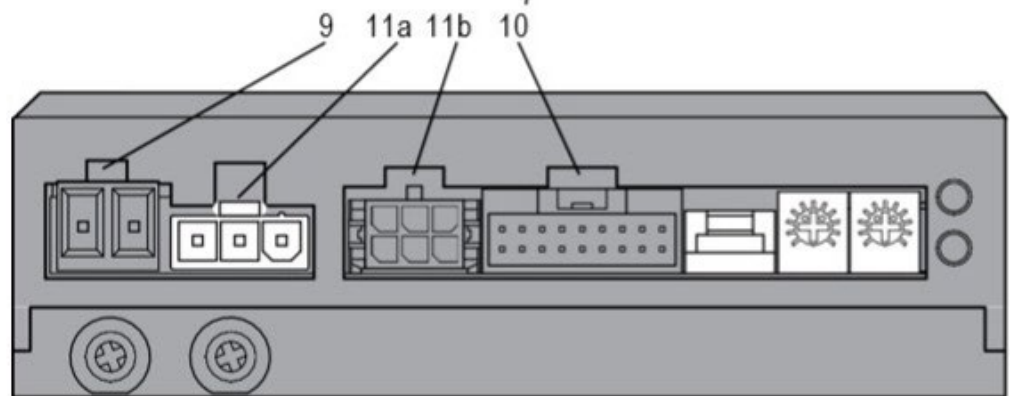

9. Disconnect the 3-pin connector (11a) and the 6-pin connector (11b) from the rotor motor reducer driver.
10. Locate the cable holder that is attached to the pump case at the right of the electronic board. Gently pull this cable holder and release the cables.

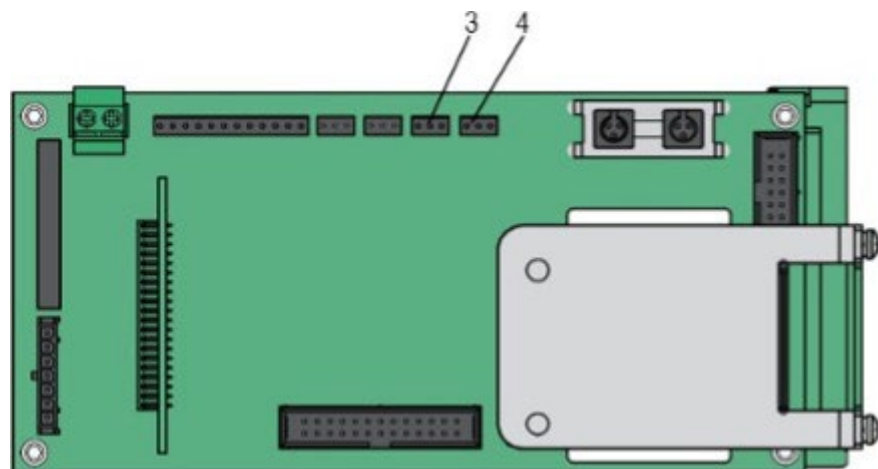

11. Locate the cable holder fixed to the pump housing at the right of the electronic board. Gently pull this cable holder and release cables 3 and 4.
12. Locate the 3 screws on the rotor motor reducer block that secure the block to the pump.

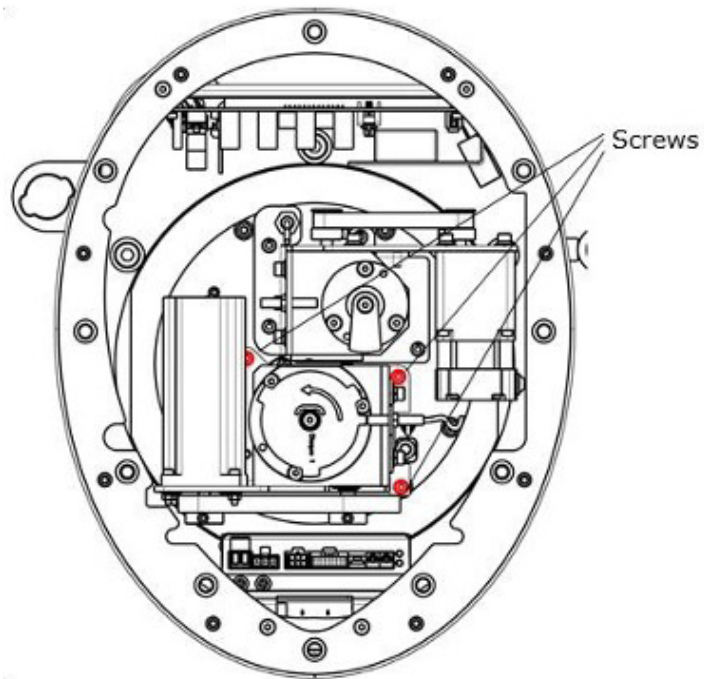

13. Use a #3 hex key to unscrew and remove the 3 screws and washers.
14. Remove the rotor motor reducer block from the pump.

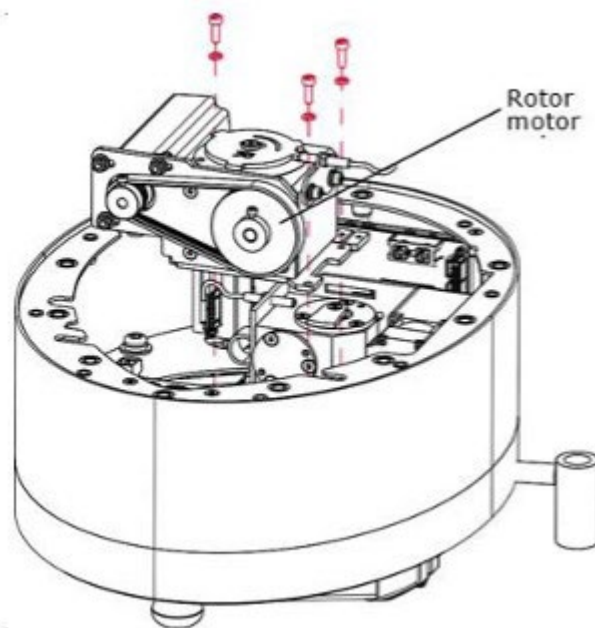

NOTE

To facilitate the installation in the isolator, do not modify the position of the rotor motor reducer belt.

15. Locate the cable holder attached to the pump housing.

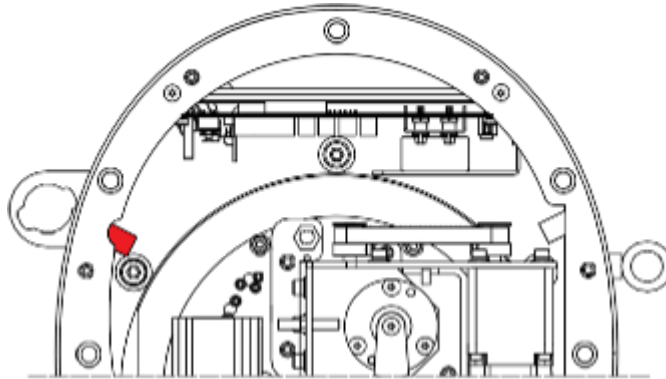

16. Gently pull this cable holder and release the cables.
17. Disconnect cables 1, 2, and 8 from the main electronic board.

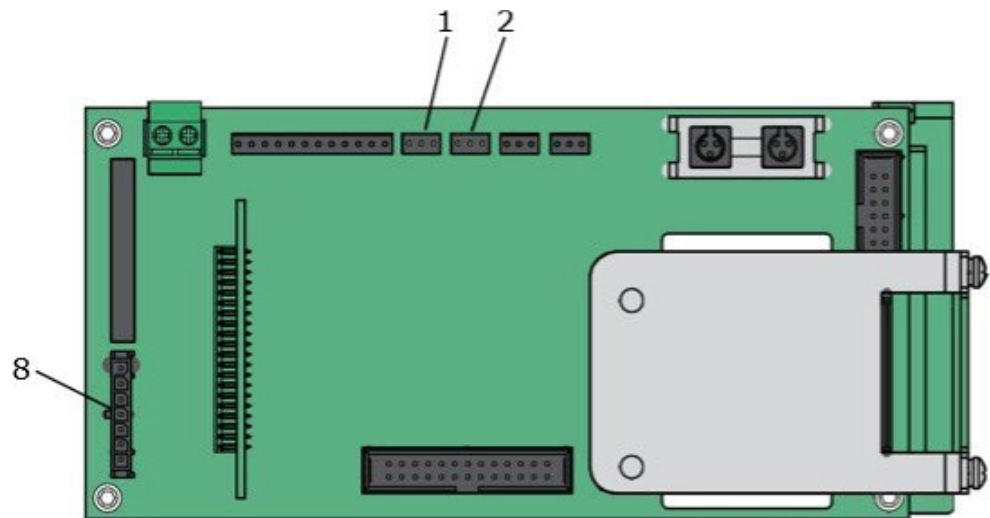

18. Locate the 4 screws on the stator motor reducer block that secure it to the pump (see previous drawing).
19. Use a #3 hex key to unscrew and remove the 4 screws and washers.

20. Remove the stator motor reducer block from the pump.

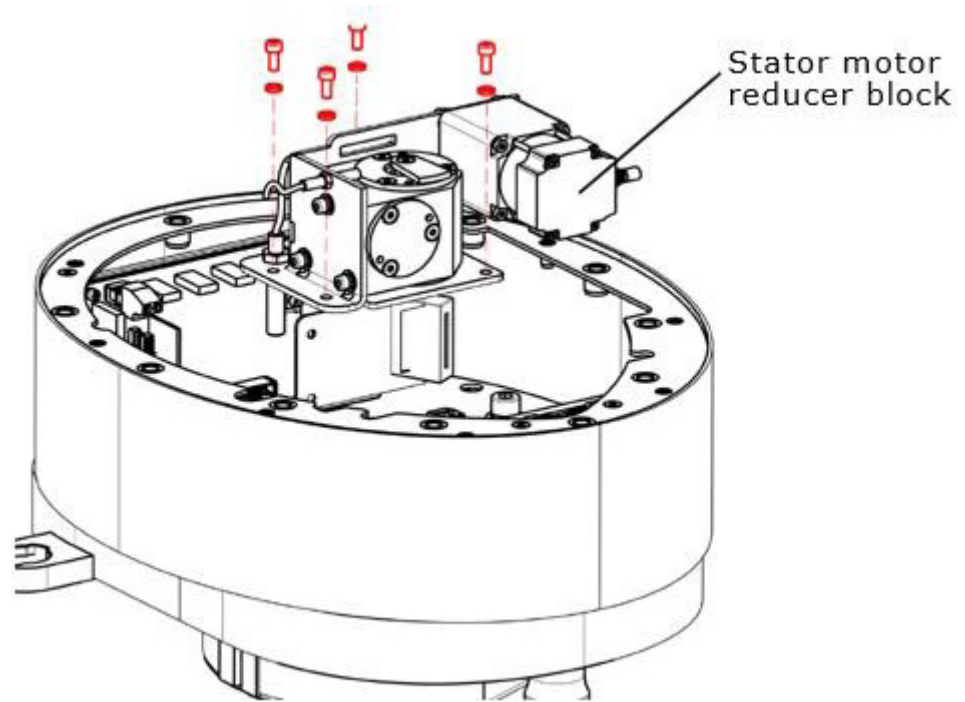

NOTE

To facilitate the installation in the isolator, do not modify the position of the stator motor reducer belt.

21. Disconnect cables 5, 6, 9, and 10 from the main electronic board (see Electronic board simplified view).

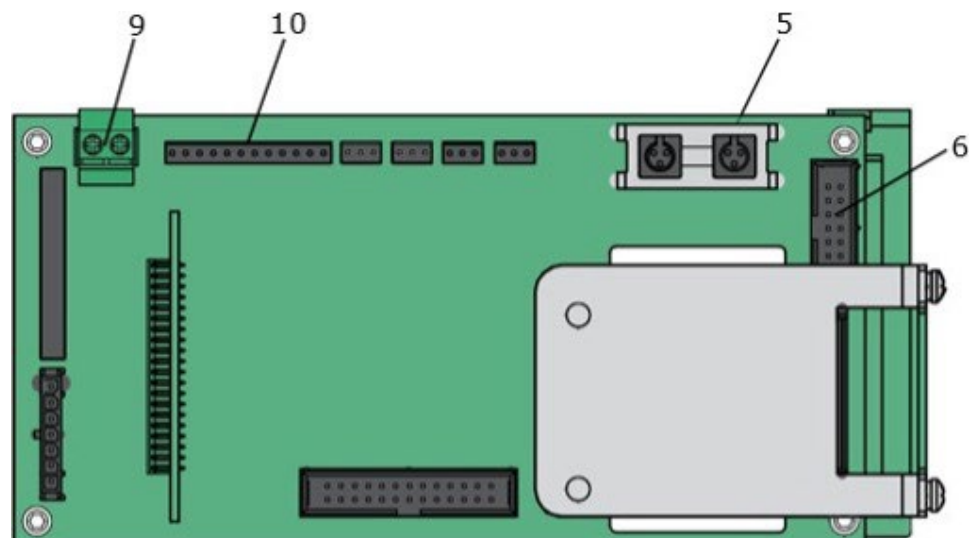

22. Locate the 2 screws that secure the electronic board to the pump housing.

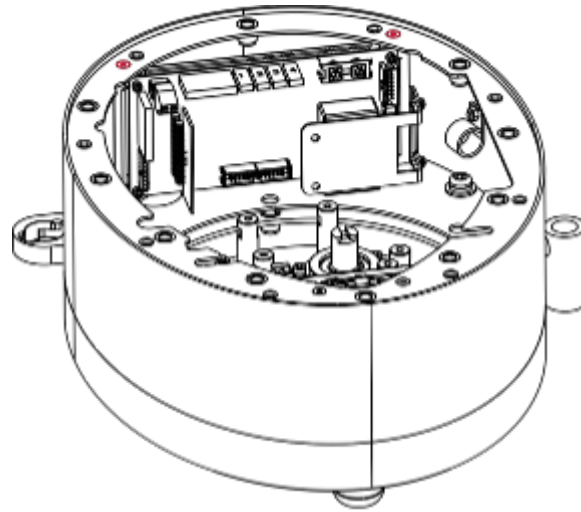

23. Use a T20 star screwdriver to unscrew the 2 screws and then remove the electronic board from the pump housing.

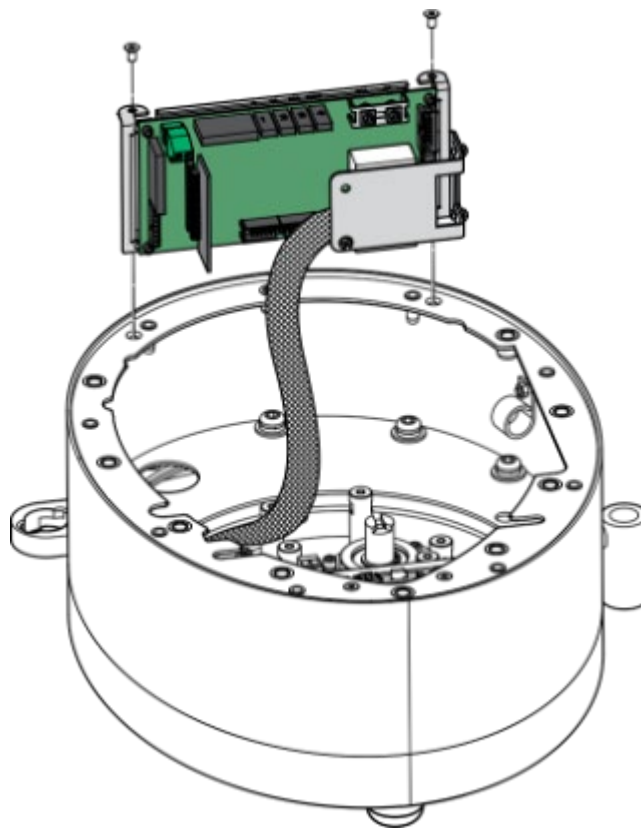

NOTE

The electronic board remains attached to the pump upper part.
Be careful not to damage it.



The electronic board is electrostatic sensitive.
Observe precautions for handling.

24. Locate the 2 screws that secure the rotor motor reducer driver to the pump housing.

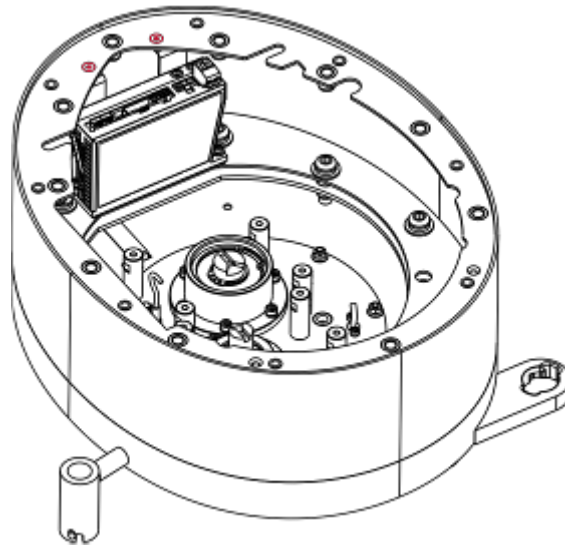

25. Use a T20 star screwdriver to unscrew the 2 screws and then remove the rotor motor reducer driver from the pump housing.

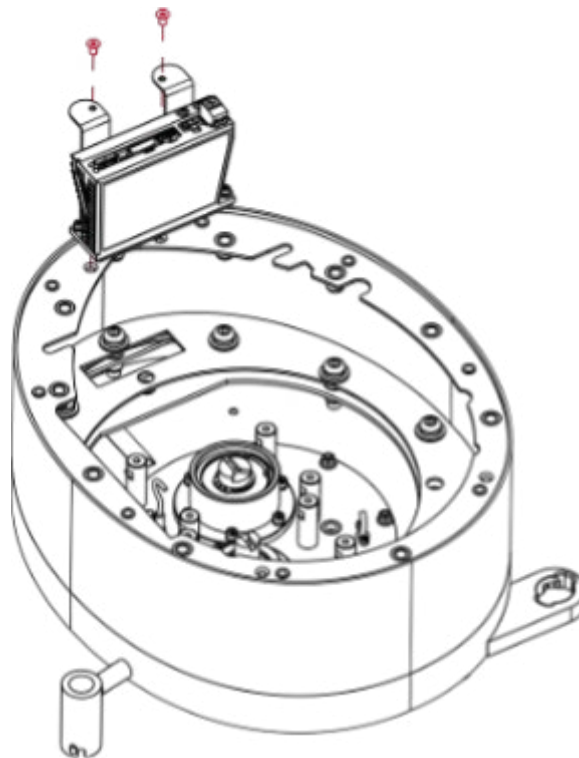

26. Locate the 11 screws on the pump housing that secure it to the pump upper part.
27. Use a #5 hex key to unscrew and remove the 11 screws and washers.

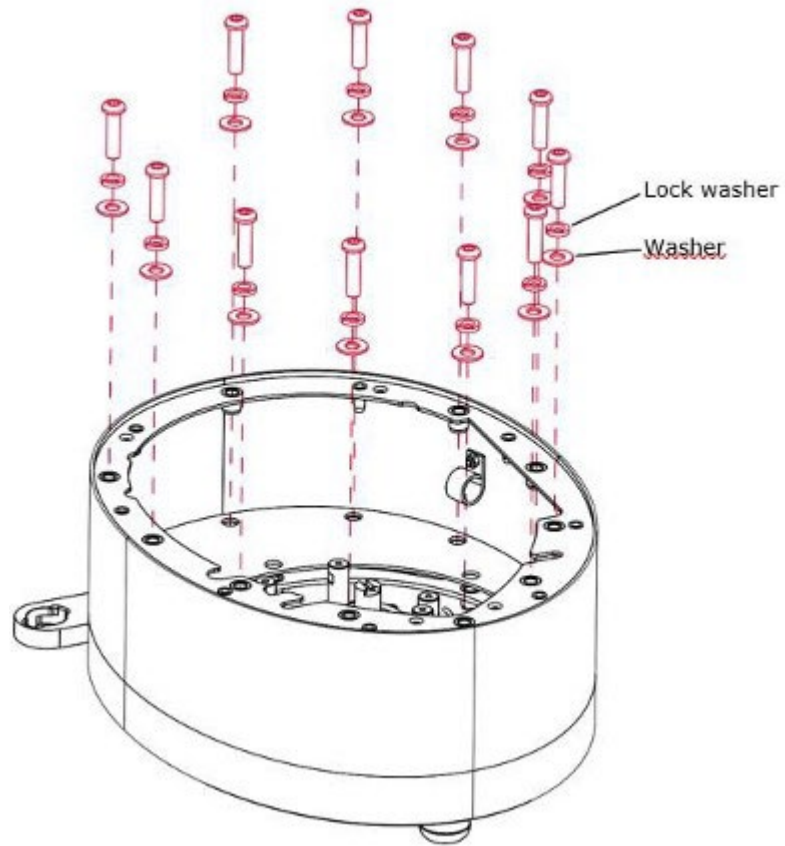

28. Remove the pump housing.

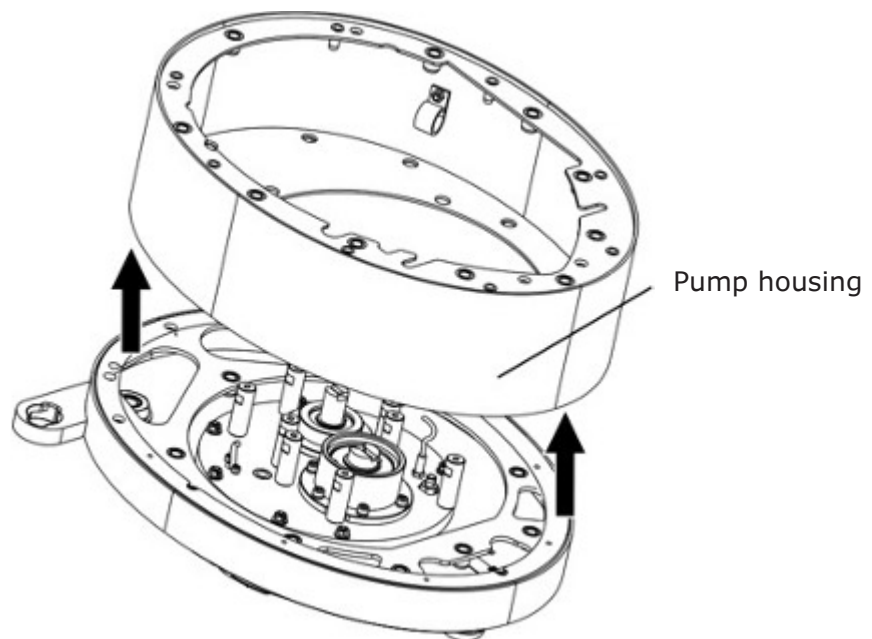

29. Remove the flat seal located on the upper part of the pump.

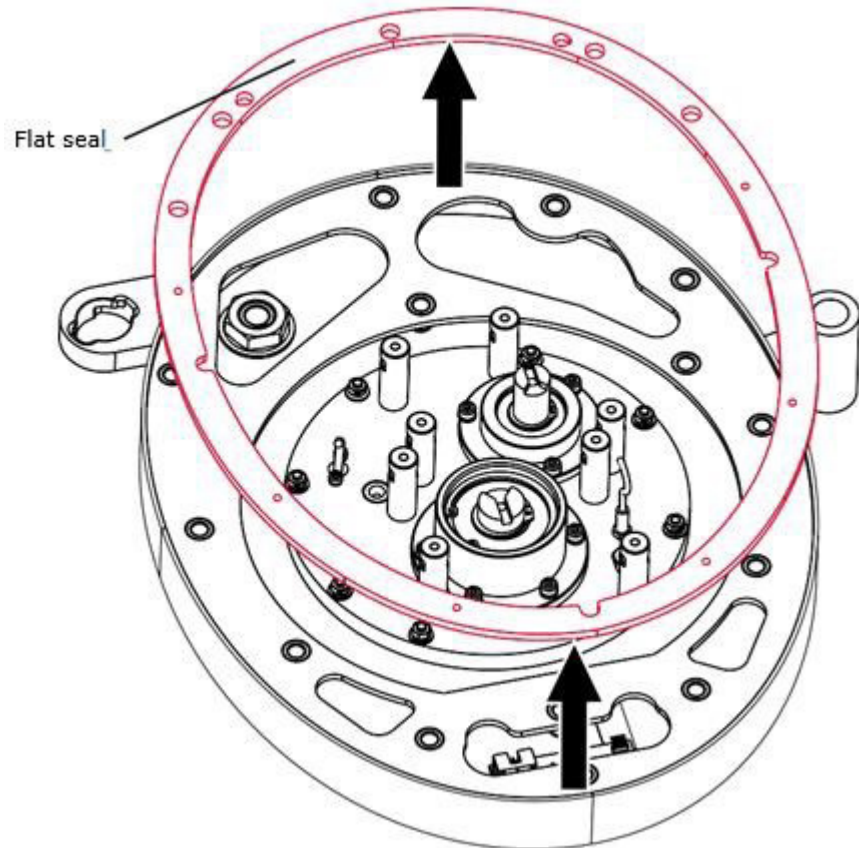

30. Retrieve the flat seal delivered in the accessories package.

31. Ensure that the flat seal is not damaged. If it is damaged, replace it with a new one (see Accessories and Replacement Parts).

32. Remove the adhesive protector and install the flat seal in place of the one removed in step 29.

33. Continue to the next section, Installing the Pump in the Isolator.

Installing the Pump in the Isolator

The Steritest® Symbio FLEX pump is compatible with standard round cutout (formerly used for the Steritest® Integral Pump and the Steritest® Equinox Isolator TQNXISL01 pump) and oval cutout (formerly used for the Steritest® Equinox Isofit pump).

Installing Using the Round Cutout

This procedure applies for the installation of a Steritest® Symbio FLEX pump on a new or existing standard round cutout. It also applies when the Steritest® Symbio FLEX pump replaces a Steritest® Integral Pump or a Steritest® Equinox Isolator TQNXISL01.

1. Place the pump case under the isolator table. To center the pump case, make sure the two threaded stems go through the corresponding pump case holes, as shown in the illustrations.

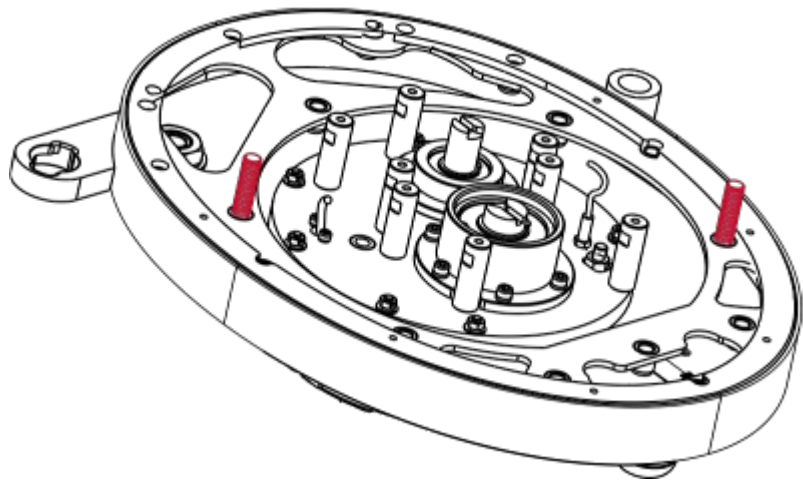

2. Turn the pump upper part right side up and place it above the isolator cutout. Make sure that all the cables and the electronic board go through the cutout.

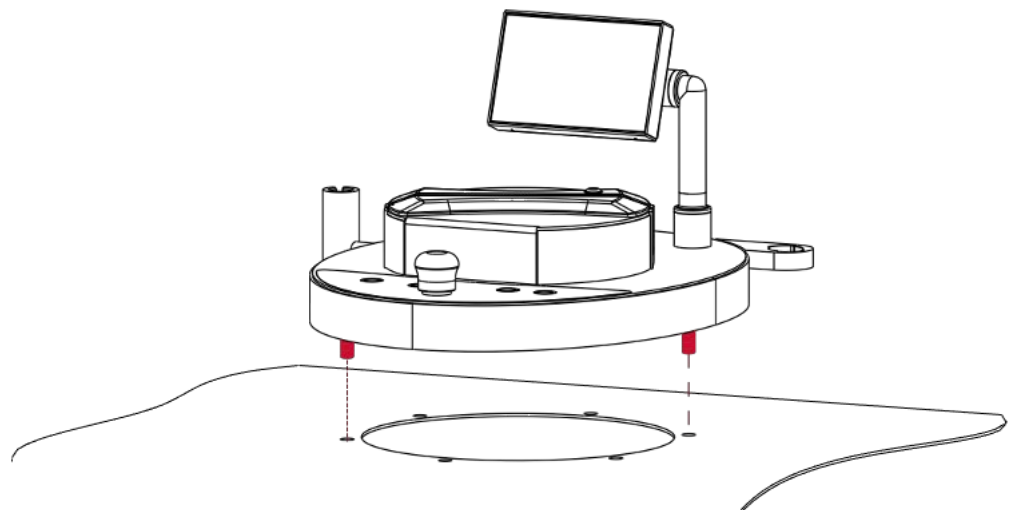

- Center the pump by placing the two threaded stems in the dedicated holes of the cutout.

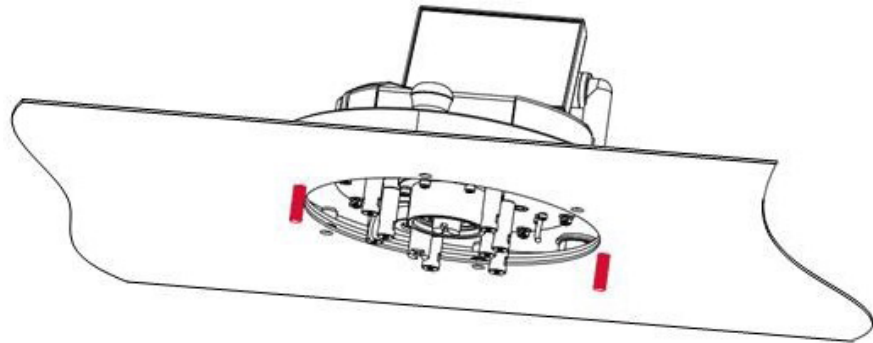

- Place the pump housing under the isolator table. To center the pump housing, make sure the two threaded stems go through the corresponding pump housing holes, as shown in the following drawings.

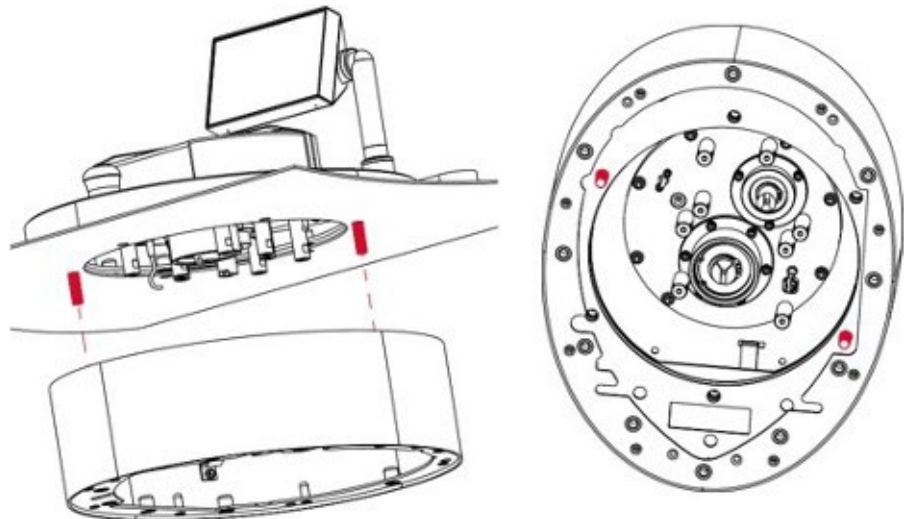

- While holding the pump housing in place, use a #5 hex key to install the 2 pump housing screws, with 2 washers each, as shown in the following drawing:

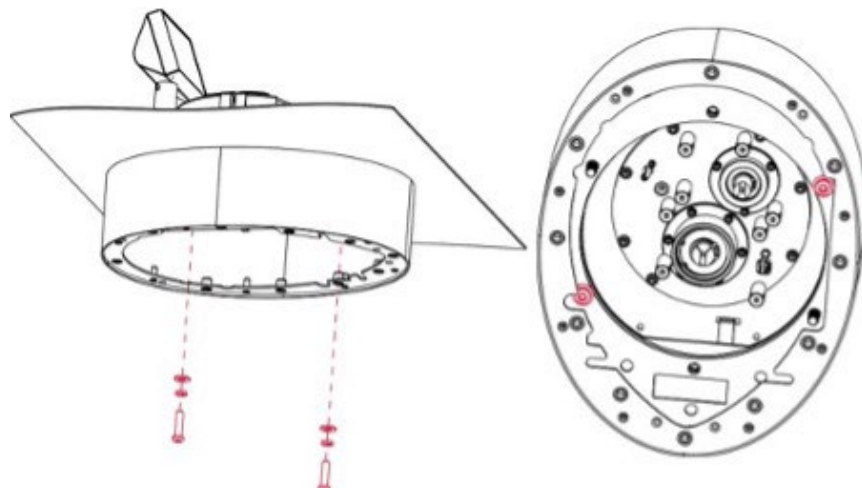

6. Remove the 2 threaded stems.

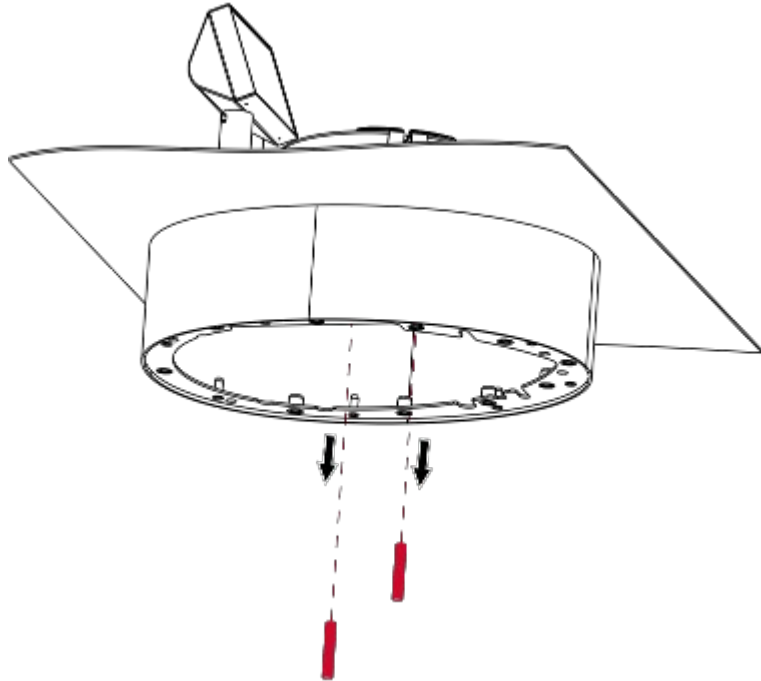

7. Place the rotor motor reducer driver in its housing. Use a T20 star screwdriver to install the two screws that secure it to the pump housing.

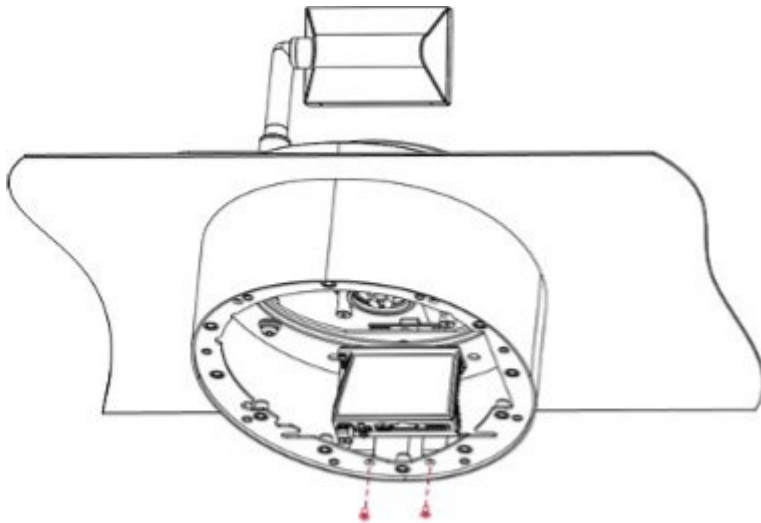

- Place the electronic board in its housing. Use a T20 star screwdriver to install the two screws that secure it to the pump housing.

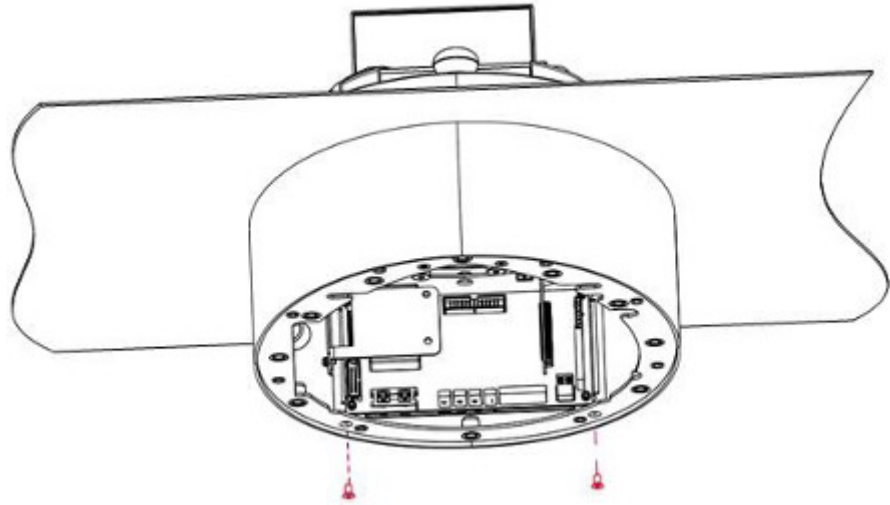

- Use a #5 hex key to install the 3 other pump housing screws, each with a washer, as shown in the following drawings.

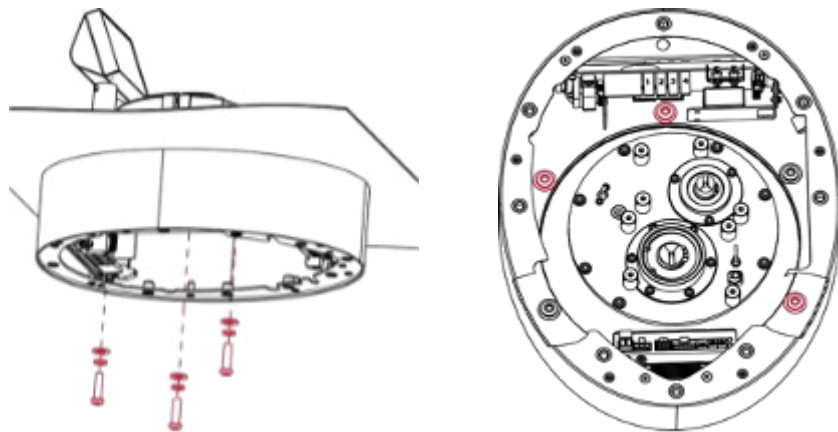

NOTE

In this configuration, 6 screws remain unused at the end of the installation.

- Perform a tightness test of the isolator before proceeding. If this test fails, ensure that all the 5 screws on the pump housing are properly installed.
- To continue, go to Reassembling the Pump Components.

Installing Using the Oval Cutout

This procedure applies when the Steritest® Symbio FLEX pump replaces a Steritest® Equinox Isofit pump.

1. Insert the two threaded stems delivered with the pump (in the accessories package) into the two M8 holes indicated in the following drawing:

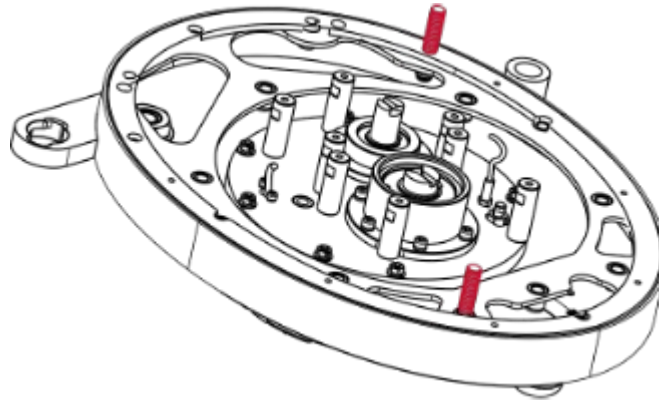

2. Turn the pump upper part right side up and place it above the isolator cutout. Make sure that all the cables, the rotor motor reducer driver, and the electronic board go through the cutout.

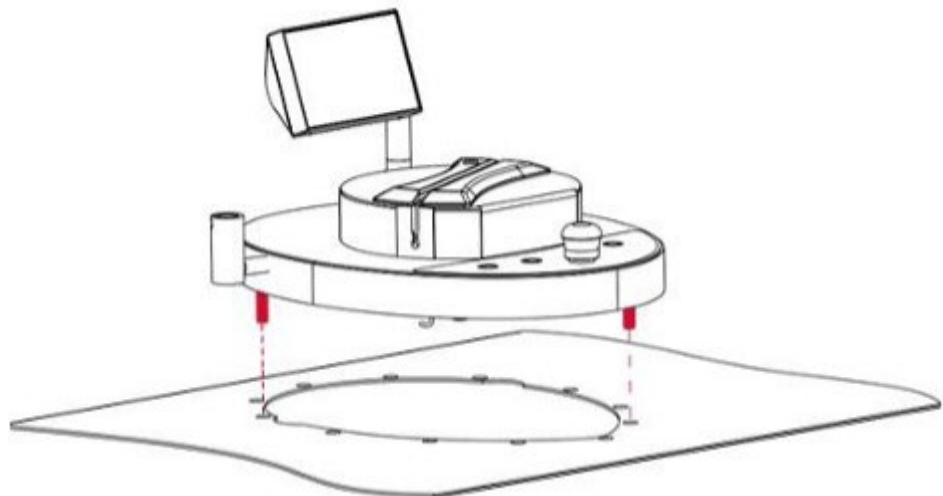

- Center the pump by placing the two threaded stems in the dedicated holes of the cutout.

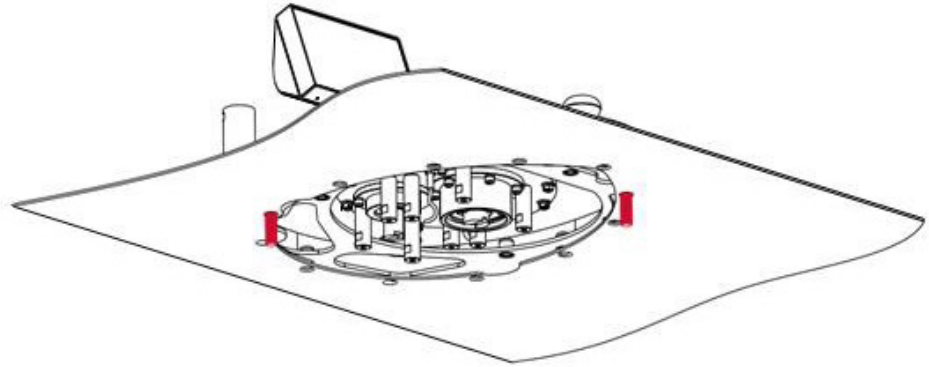

- Place the pump housing under the isolator table. To center the pump housing, make sure the two threaded stems go through the corresponding pump housing holes, as shown in the following drawings:

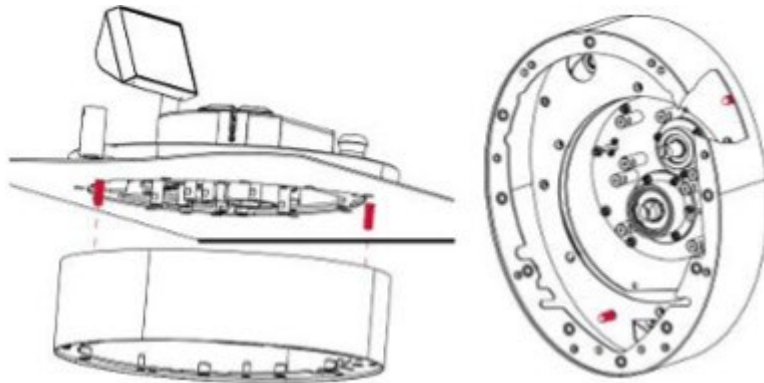

- While holding the pump housing in place, use a #5 hex key to install the 2 pump housing screws, with 2 washers each, as shown in the following drawing:

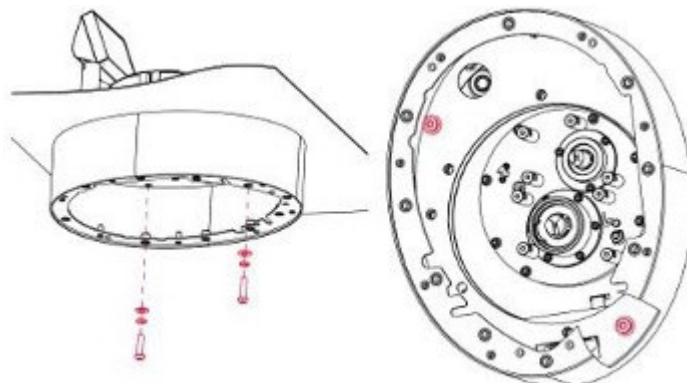

6. Remove the 2 threaded stems.

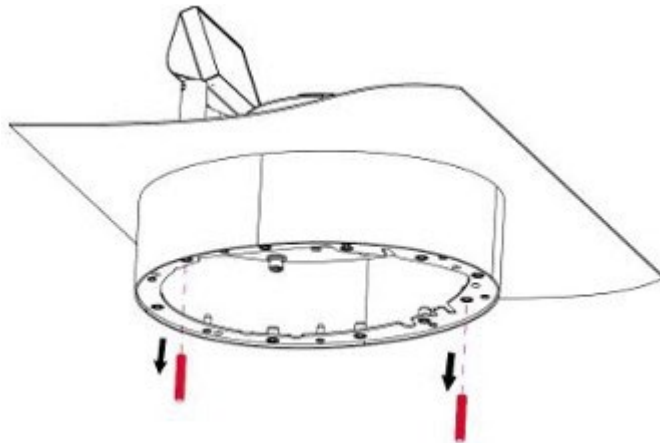

7. Use a #5 hex key to install the 7 additional pump housing screws, with 2 washers each, as shown in the following drawing:

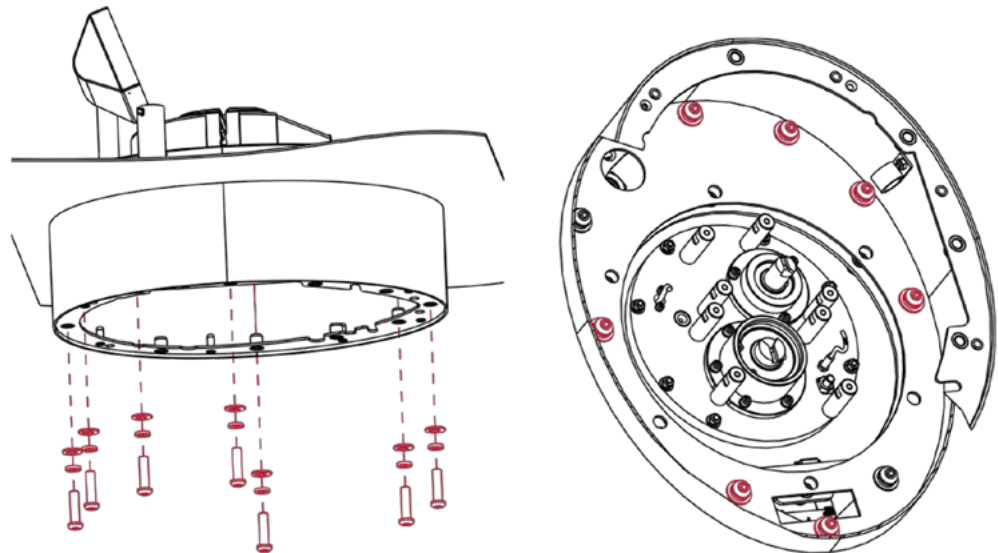

NOTE

In this configuration, 2 screws remain unused at the end of the installation.

8. Perform a tightness test of the isolator before proceeding.

If this test fails, ensure that all the 9 screws on the pump housing are properly installed.

9. Place the rotor motor reducer driver in its housing. Use a T20 star screwdriver to install the two screws that secure it to the pump housing.

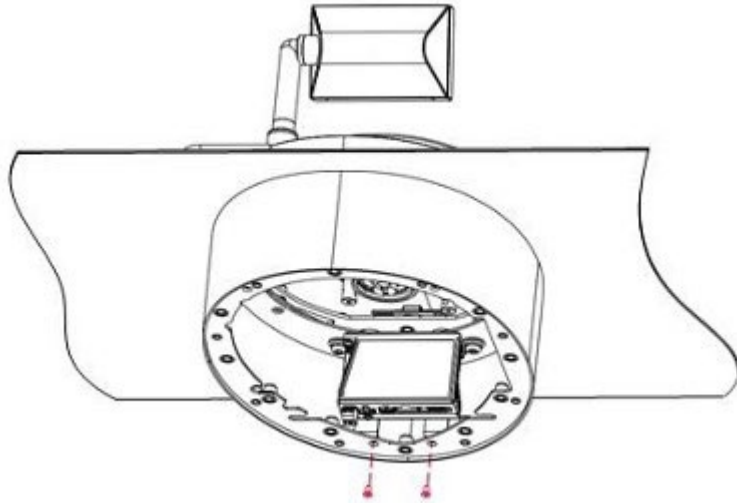

10. Place the electronic board in its housing. Use a T20 star screwdriver to install the two screws that secure it to the pump housing.

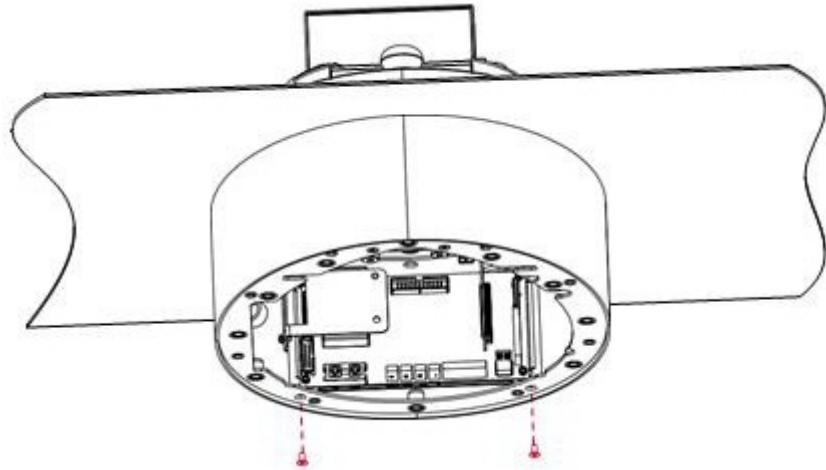

11. Continue to the next section, Reassembling the Pump Components.

Reassembling the Pump Components

NOTE

This procedure applies for both round and oval cutouts.

1. Connect cable 6 to the electronic board.

This ribbon cable is permanently attached to the pump upper part. It goes to the right of the stator motor reducer block, goes through the cable holder located at the right of the electronic board, and is connected to the electronic board.

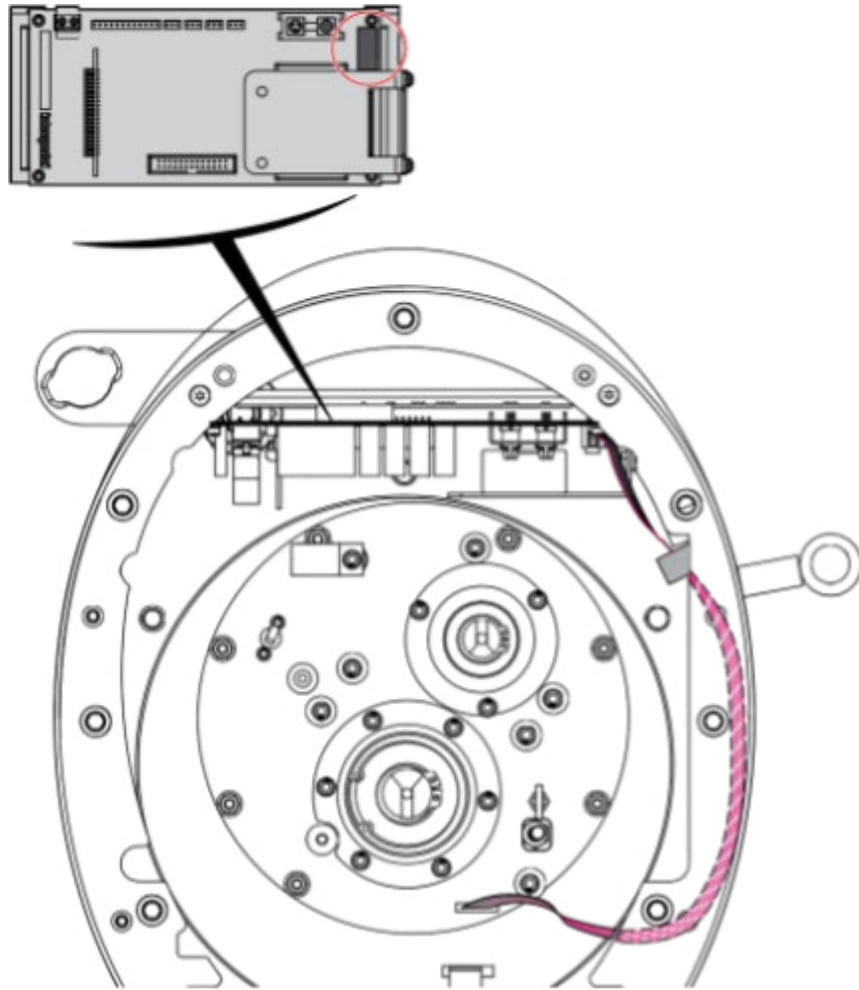

2. Bring the stator motor reducer block under the pump housing and connect cable 8 to the electronic board.

This cable comes from the stator motor reducer block. It goes to the right of this motor reducer block, goes through the cable holder located at the right of the electronic board, then goes behind the electronic board, and is finally connected to the electronic board.

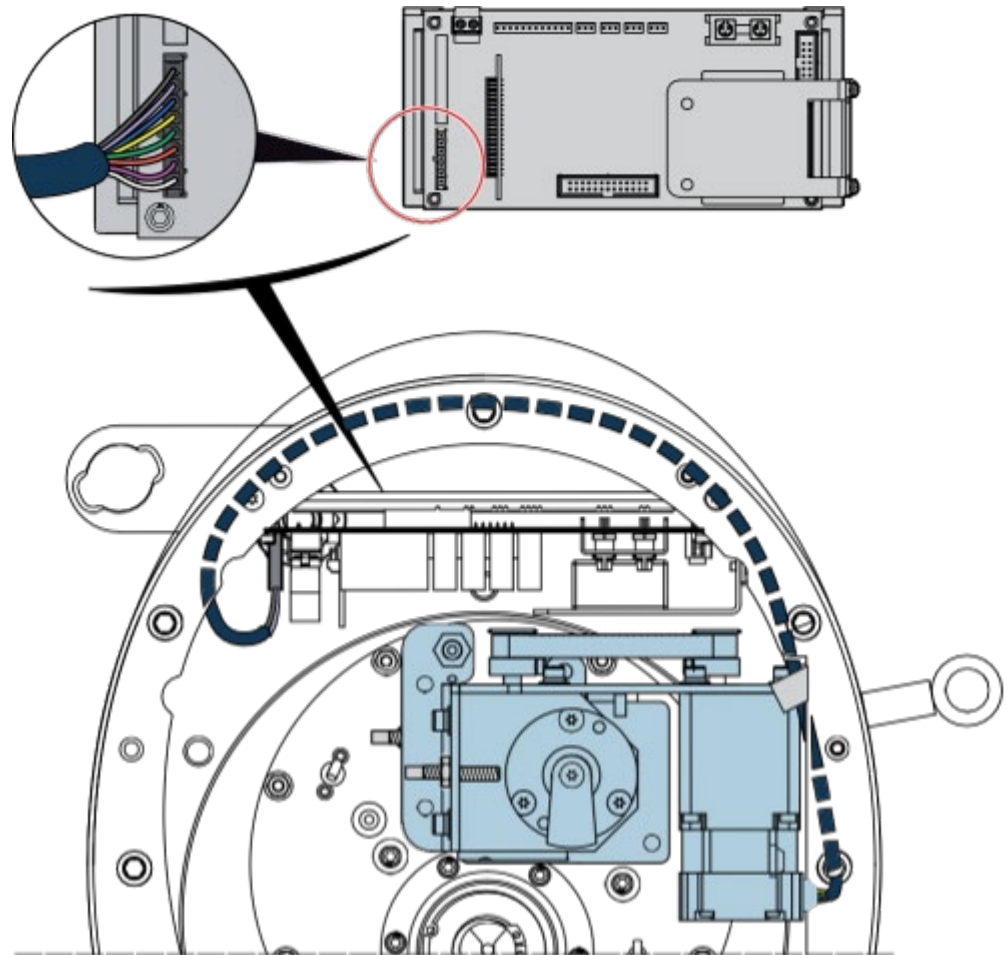

3. Place the stator motor reducer block in its housing by aligning the coupling pieces located on the stator motor reducer block and at the bottom of the pump upper part.

NOTE

Do not turn the coupling piece located at the bottom of the pump upper part. If the position of the stator motor reducer belt has not been modified during the disassembly step, the alignment should be okay. If necessary, turn the stator motor reducer belt to adjust the orientation of the coupling piece located on the stator motor reducer block.

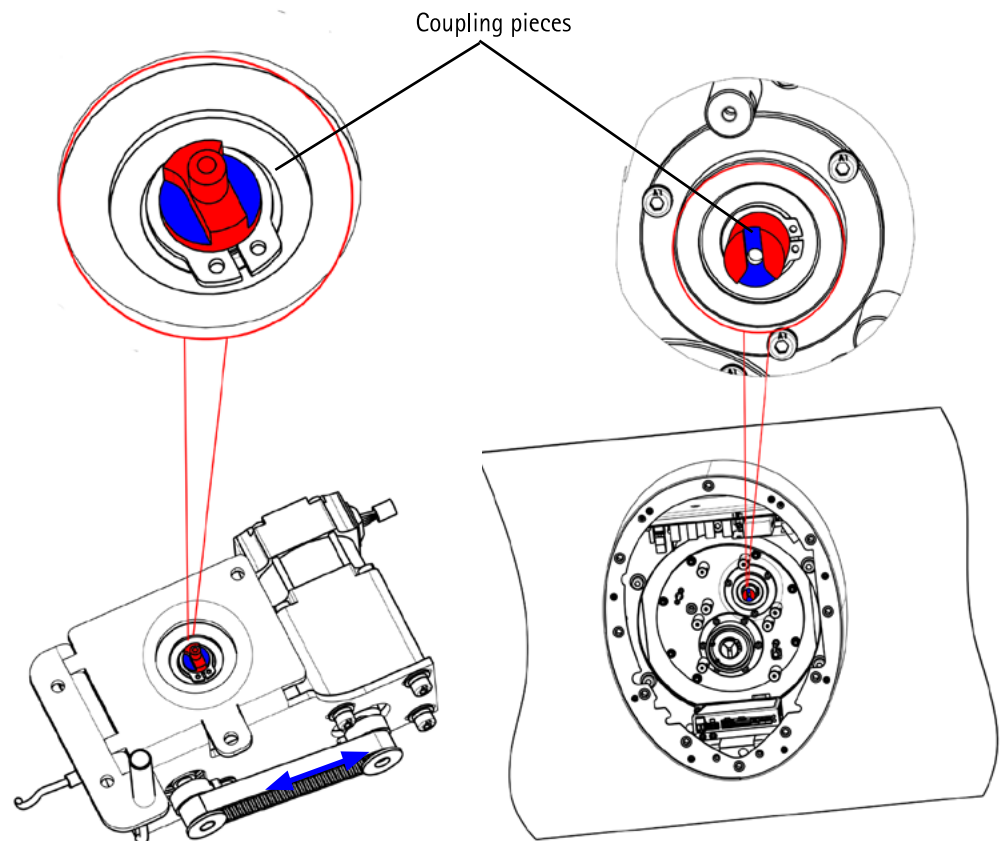

4. Use a #3 hex key to install the 4 screws and washers and the cable holder to secure the

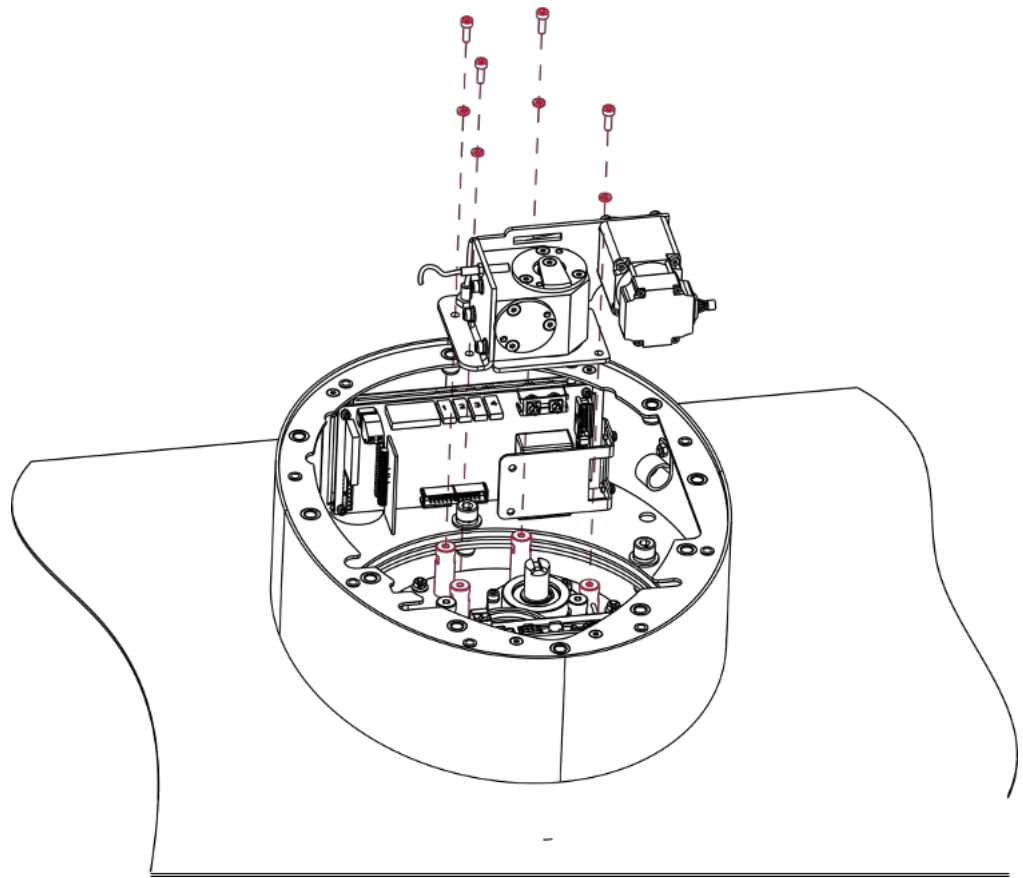

5. Connect cable 1 to the electronic board.

This cable is permanently attached to the pump upper part. It loops in the cable holder attached to one of the stator motor reducer screws and is connected to the electronic board.

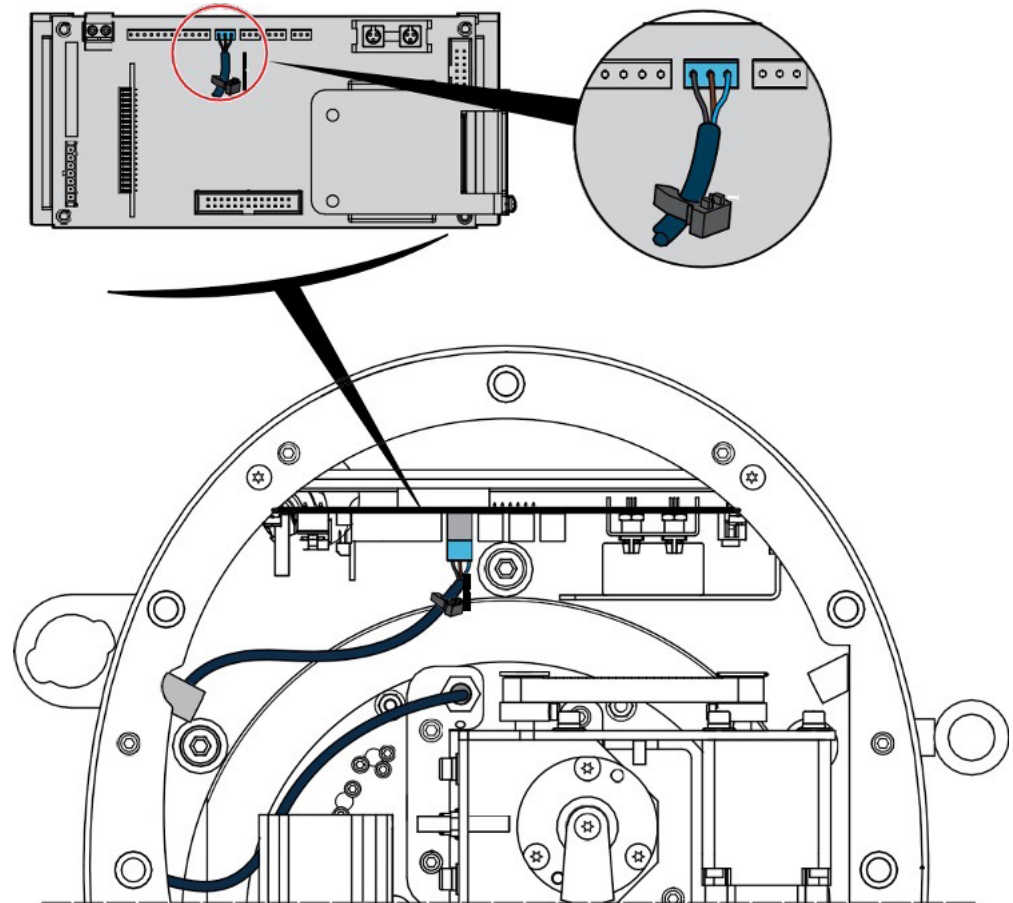

6. Connect cable 2 to the electronic board.

This cable comes from the stator motor reducer block. It loops in the cable holder attached to one of the stator motor reducer screws and is connected to the electronic board.

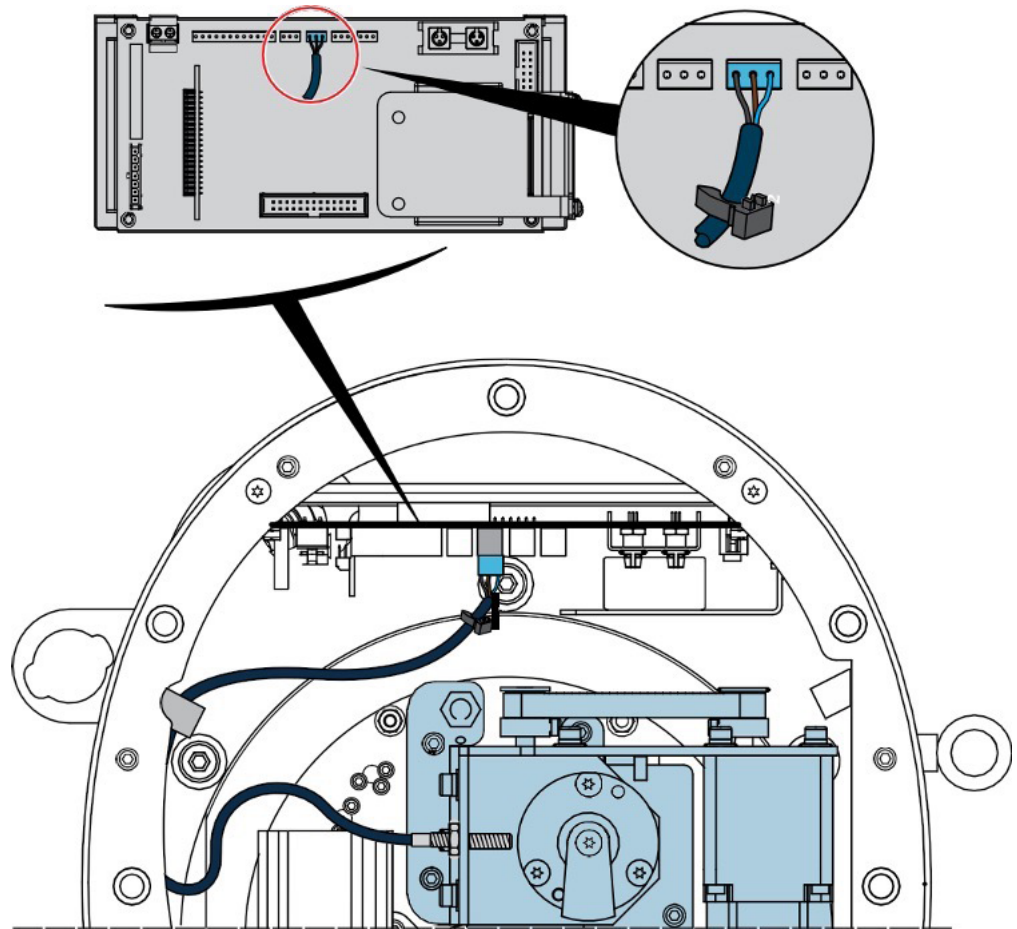

7. Connect cable 5 to the electronic board.

This cable is permanently attached to the pump upper part. It double loops in the cable holder attached to one of the stator motor reducer screws, and is connected to the electronic board.

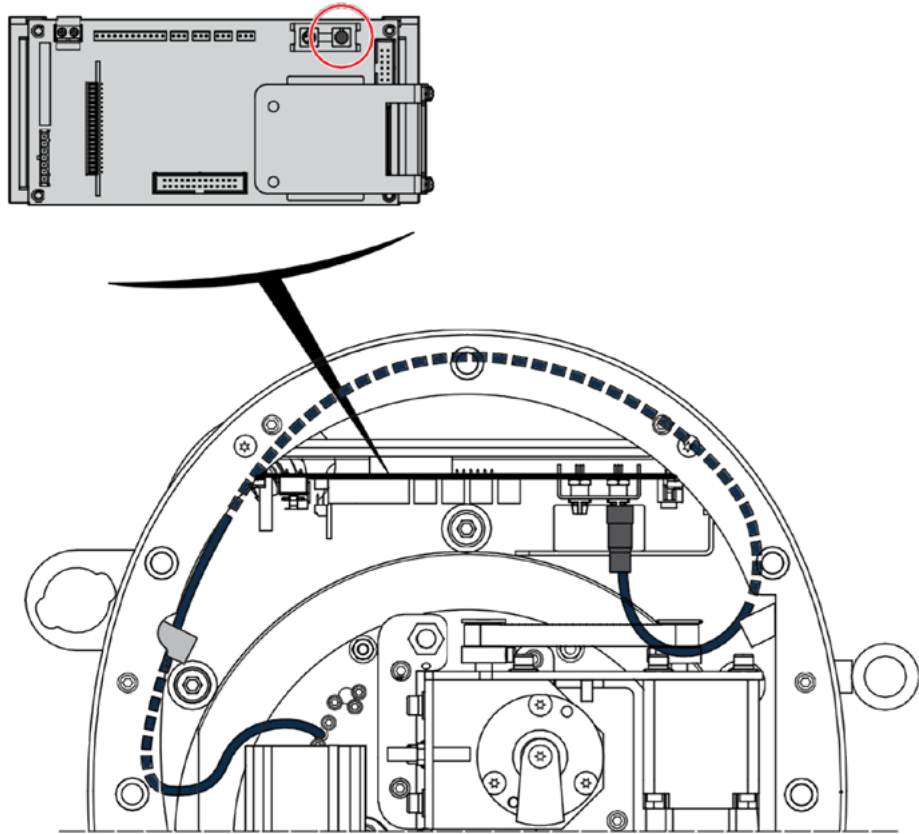

- Place the rotor motor reducer block in its housing by aligning the coupling pieces located on the rotor motor reducer block and at the bottom of the pump upper part.

NOTE

Do not turn the coupling piece located at the bottom of the pump upper part. If the position of the rotor motor reducer belt has not been modified during the disassembly step, the alignment should be okay. If necessary, turn the rotor motor reducer belt to adjust the orientation of the coupling piece located on the rotor motor reducer block.

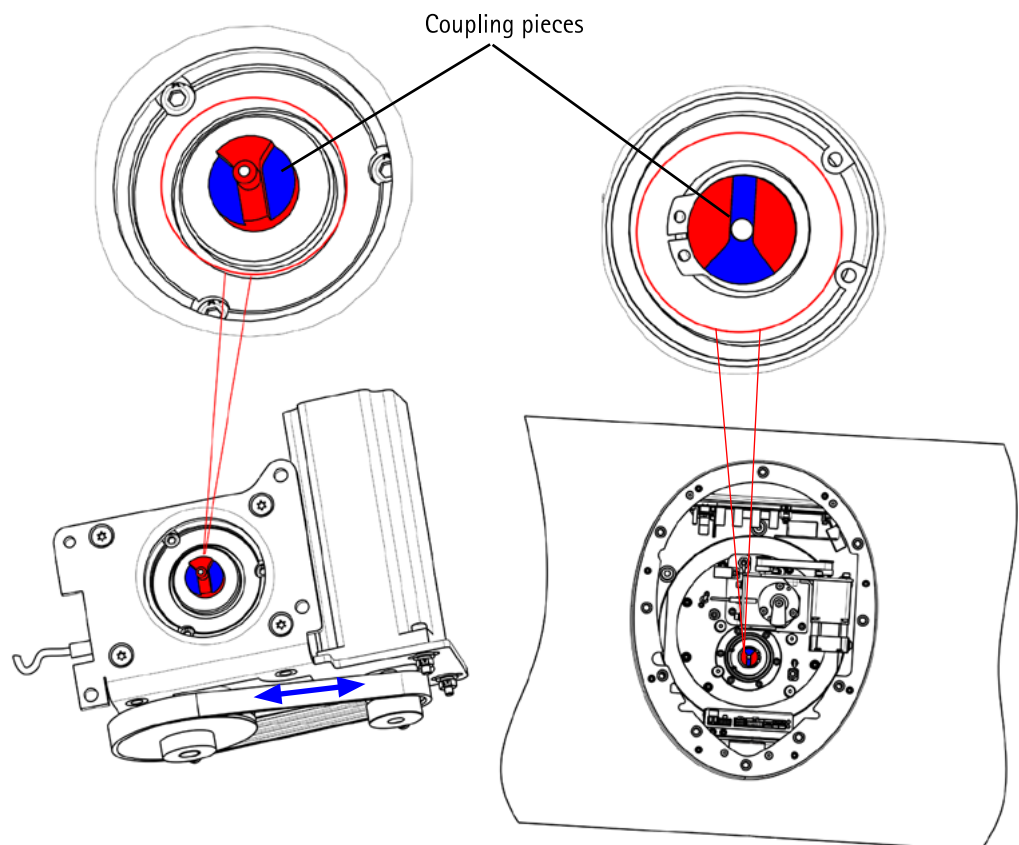

9. Use a #3 hex key to install the 3 screws and washers to secure the rotor motor reducer block to the bottom of the pump upper part.

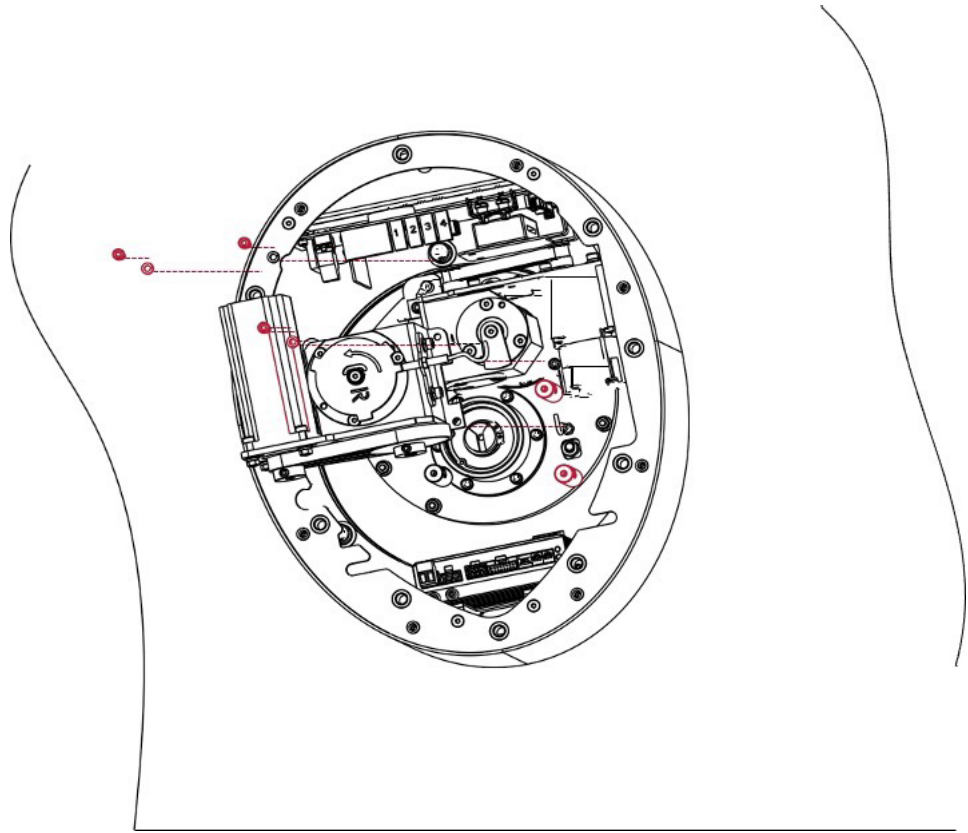

10. Connect cable 9 to the electronic board.

This cable links the rotor motor reducer driver to the electronic board. From the motor reducer driver (2-pin connector), the cable goes behind this rotor motor reducer driver, then to the left of the rotor motor reducer block, then through the cable holder attached to one of the stator motor reducer screws and is connected to the electronic board.

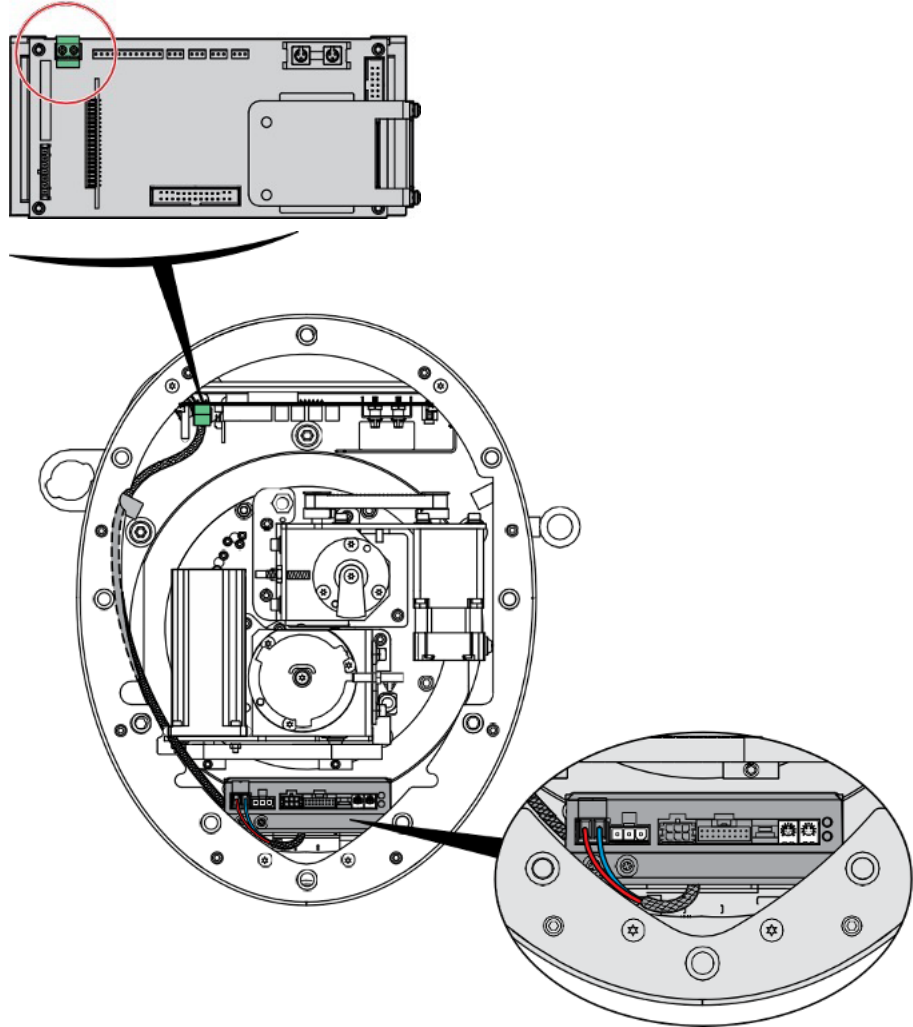

11. Connect cable 10 to the electronic board.

This cable links the rotor motor reducer driver to the electronic board. From the motor reducer driver (18-pin connector), the cable goes behind this rotor motor reducer driver, then to the left of the rotor motor reducer block, then through the cable holder attached to one of the stator motor reducer screws and is connected to the electronic board.

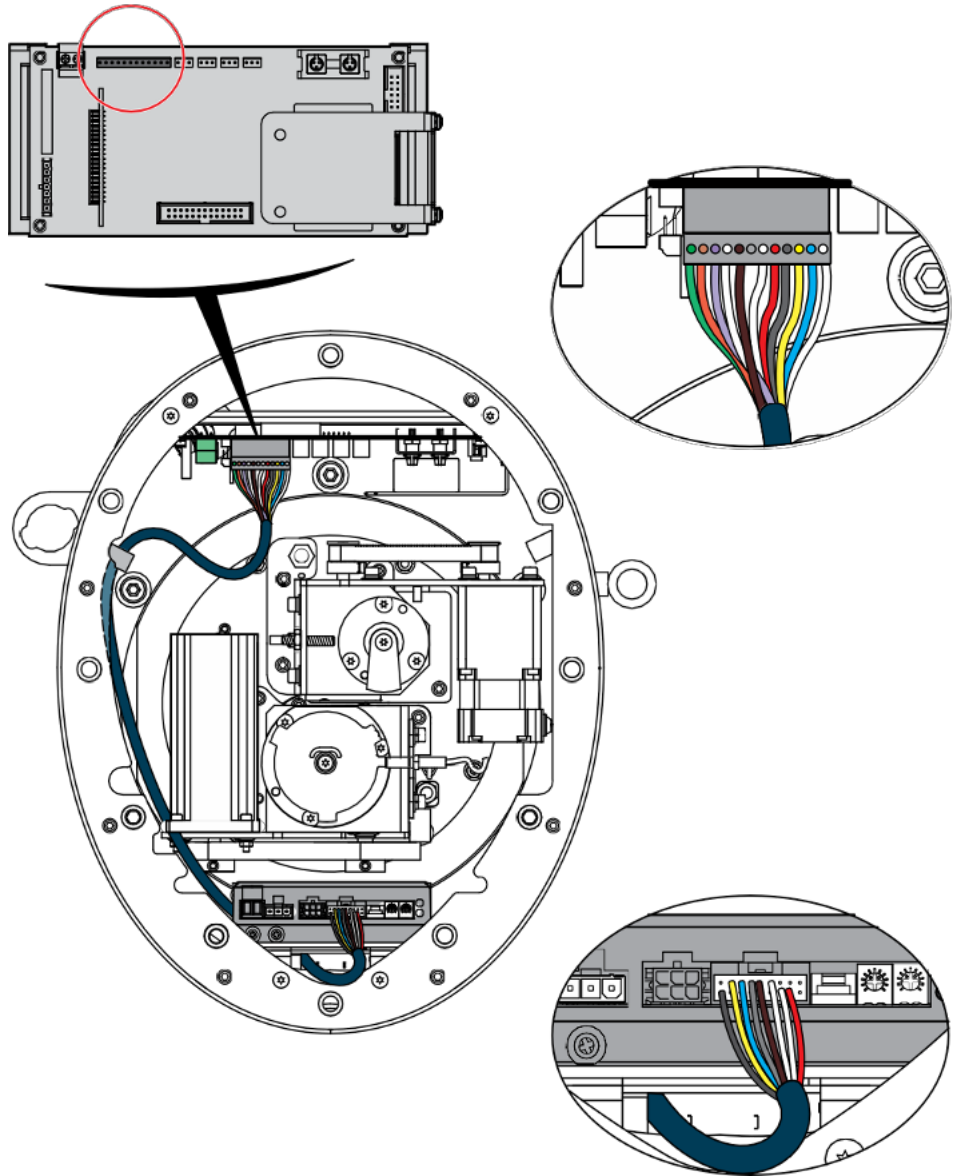

12. Connect the 3-pin connector (11a) and the 6-pin connector (11b) to their bases on the motor reducer driver.

Cable 11 comes from the rotor motor reducer block, goes to the left of this motor reducer block, then goes behind the rotor motor reducer driver to which it is finally connected.

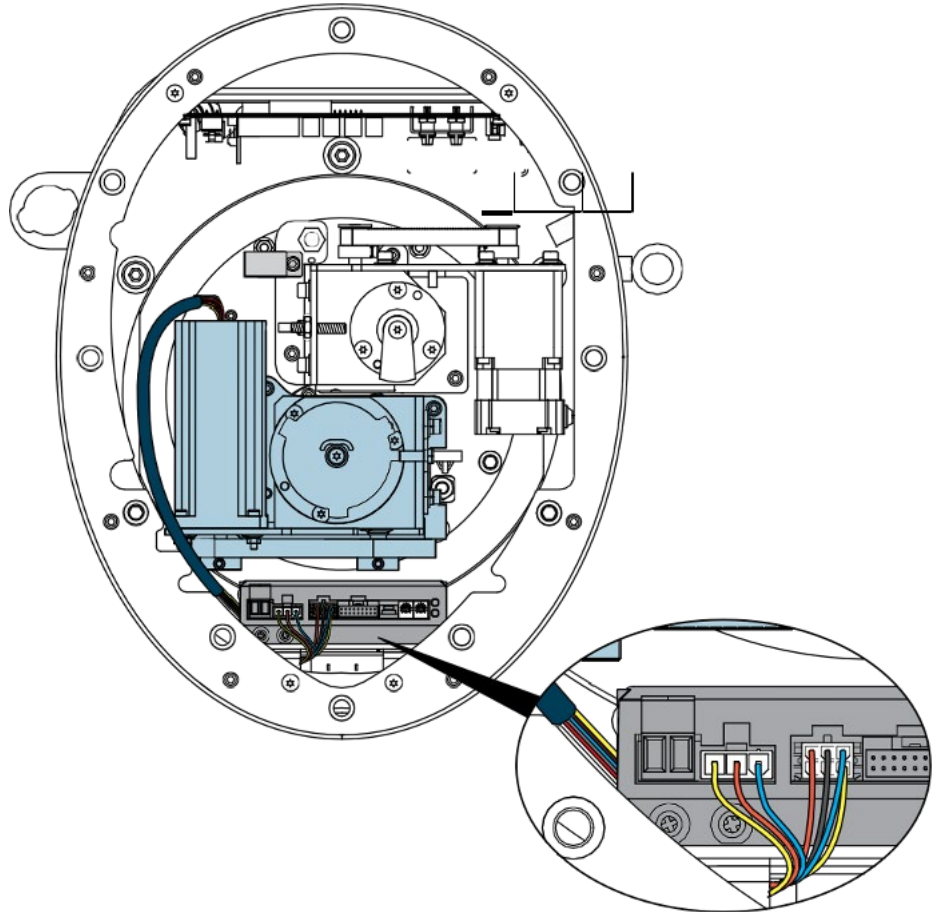

13. Connect cable 3 to the main electronic board.

This cable is permanently attached to the pump upper part. It goes to the right of the stator motor reducer block, then through the cable holder located at the right of the electronic board and is connected to the electronic board.

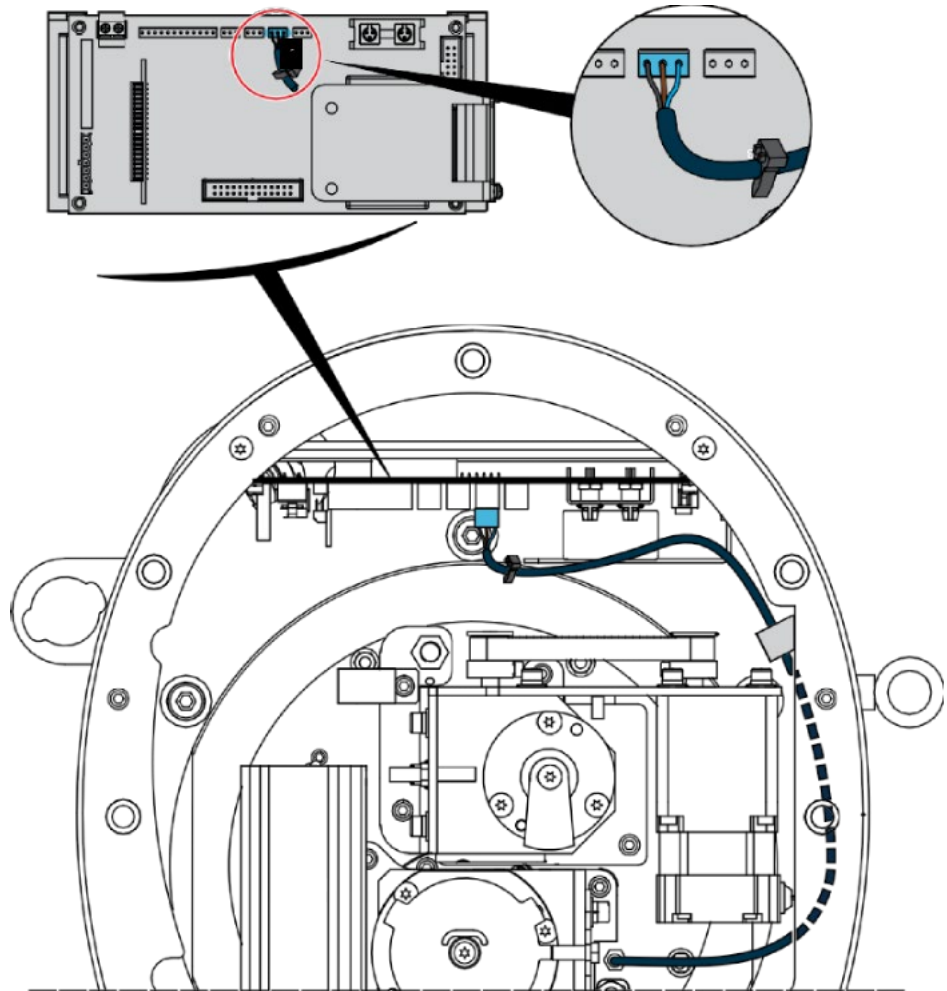

14. Connect cable 4 to the main electronic board;

This cable comes from the rotor motor reducer block, goes to the right of the stator motor reducer block, then through the cable holder located at the right of the electronic board, and is connected to the electronic board.

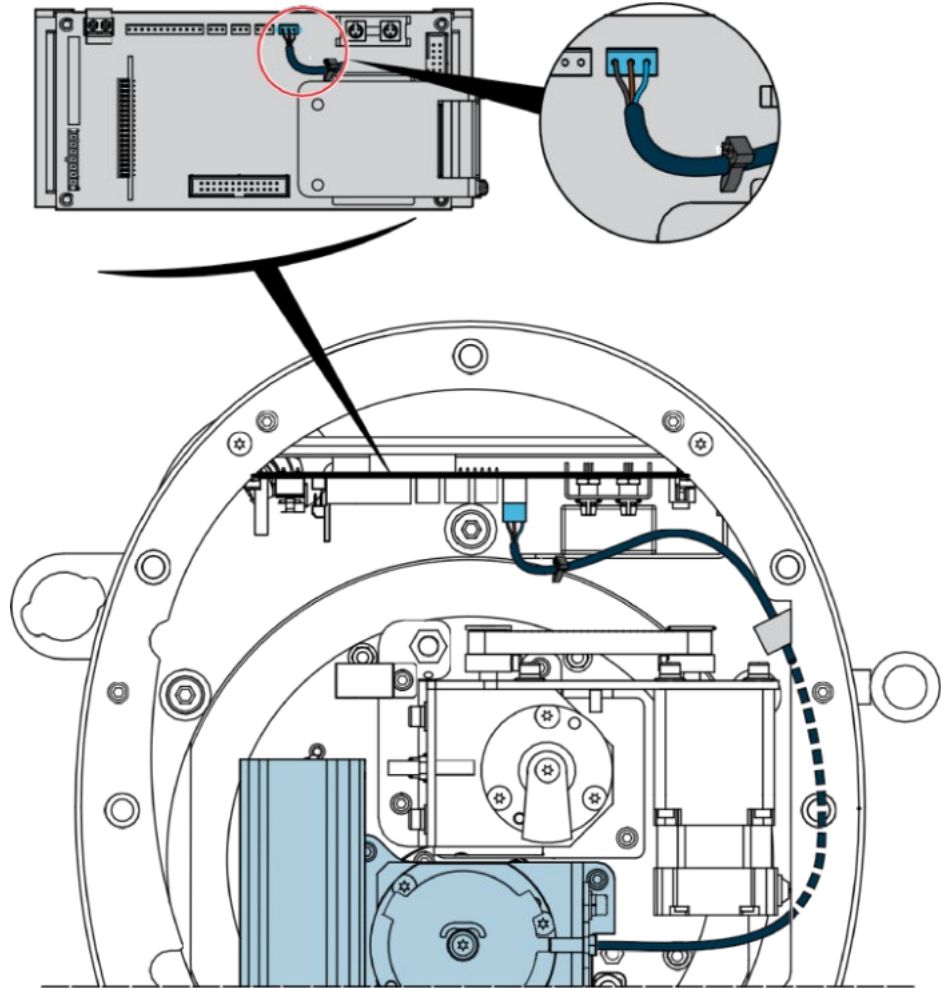

15. Ensure that no cable passes near the belts of the two motor reducer blocks or under the two motor reducer blocks.

16. Position the pump bottom plate underneath the pump housing.
17. Connect the power connector cable to the power connector located on the pump bottom plate, and then place the bottom plate under the pump housing.

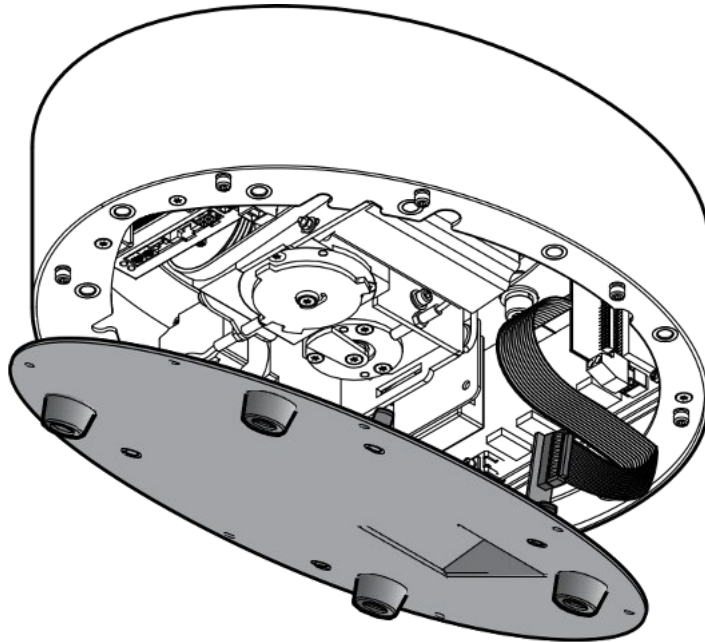

18. Use a T20 star screwdriver to install the 8 screws that attach the bottom plate to the pump housing.

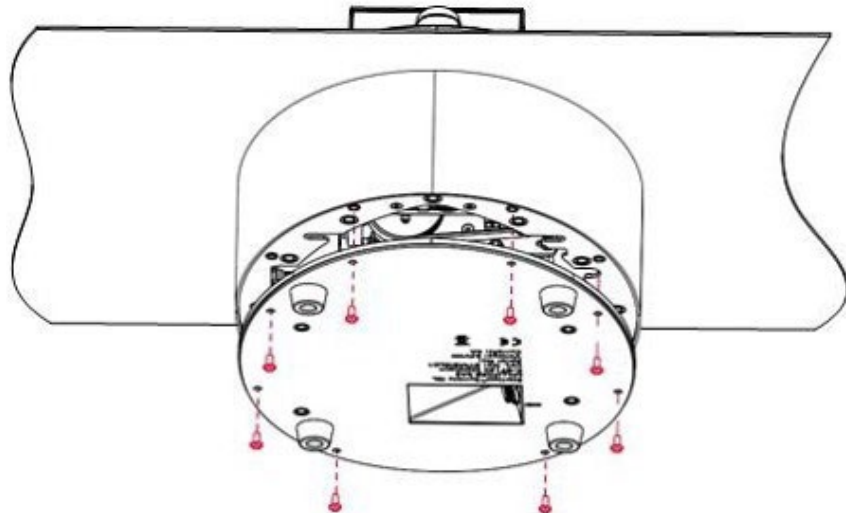

19. Connect the communication hub pump connection cord to the pump power inlet.
20. Connect the communication hub to power source using the power cord delivered with the pump.



NOTE

The communication hub can be installed under the isolator using the optional communication hub holder for isolator (see *Installing the Communication Hub Under the Isolator: Low Integration*). It can also be fixed to one of the isolator feet, using the optional communication hub holder for hoods (see *Accessories*

and Replacement Parts).

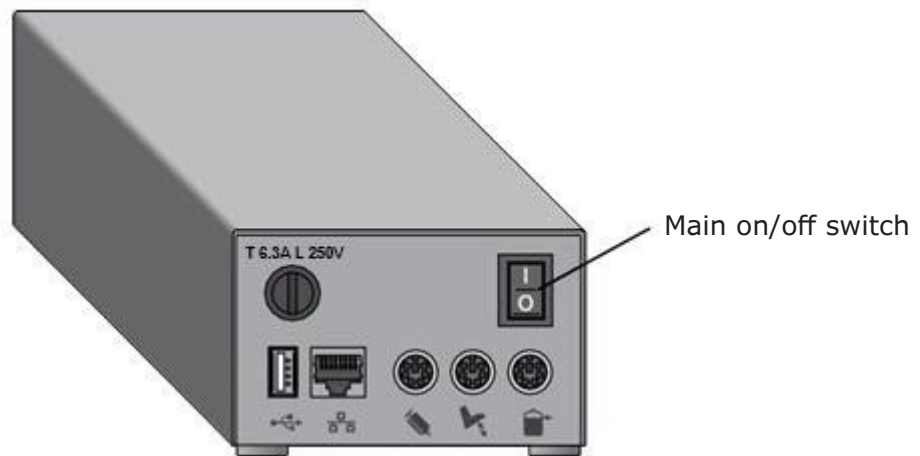
21. Switch on the communication hub by pressing the on/off switch (position I).



22. Simultaneously press and hold the pump on/off  and the open/close  buttons. The screen displays the range of Steritest® devices. This is followed by the welcome screen:



23. After a few seconds, the following screen displays:



24. When the autotest is complete, the following screen displays. A ✓ symbol in a check box indicates that an accessory or data source is connected to the communication hub.

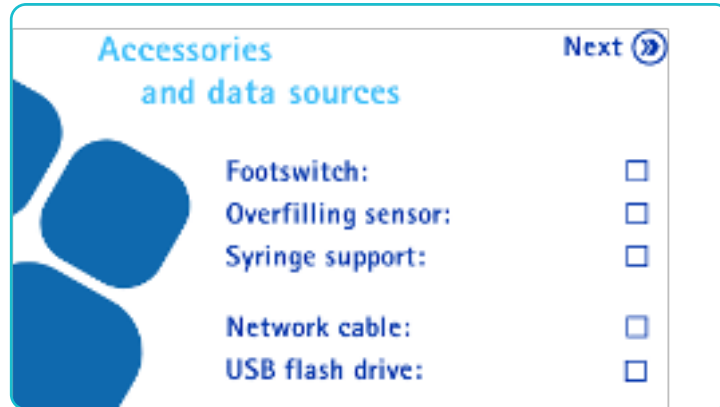

25. Press the  button. The installation menu displays.

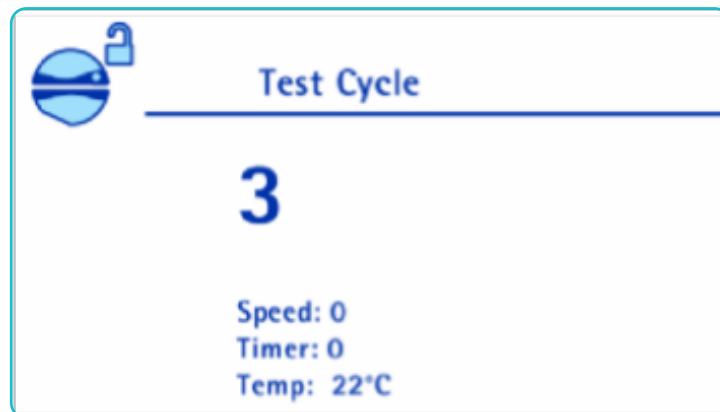

26. Turn the control knob to select **After Installation in Isolator**.

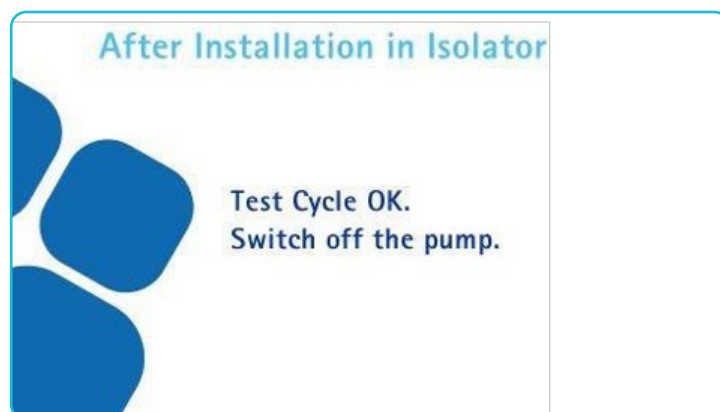

27. Press the control knob. The **After Installation in Isolator** screen displays.

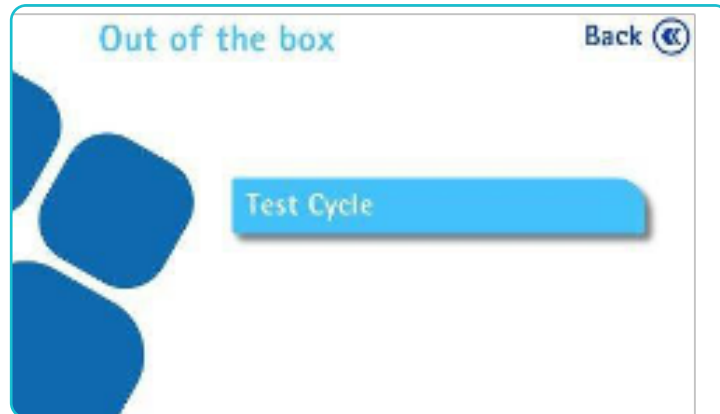

28. Press the control knob to begin the test cycles. Three cycles will be performed.



29. After the pump head closes, the pump starts automatically, and 3 test cycles

are performed.

30. When all 3 test cycles complete with no error, the following screen displays.

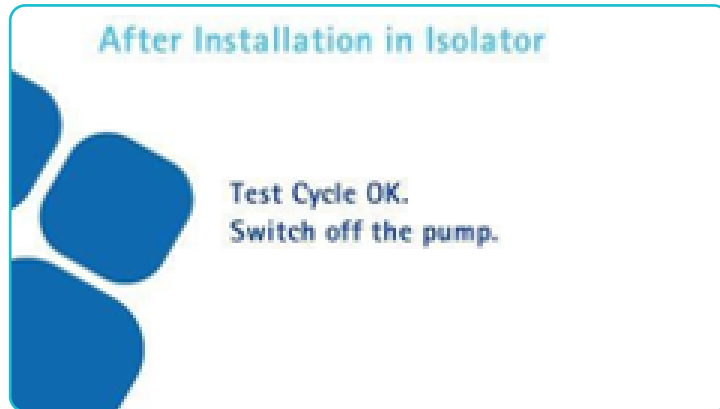

31. Switch off the communication hub by pressing the on/off switch (position O). The Shutdown screen displays.



32. Disconnect the communication hub pump connection cord from the pump power inlet.

Installing the Communication Hub under the Isolator: Low Integration

Use the optional communication hub holder for isolators to install the communication hub under the isolator table (see Accessories and Replacement Parts). Multiple configurations are possible.

Installing the Communication Hub on the Side, High Version

Installing to the Left of the Pump

1. Use the small screws and washers to attach the holder to the bottom of the communication hub.

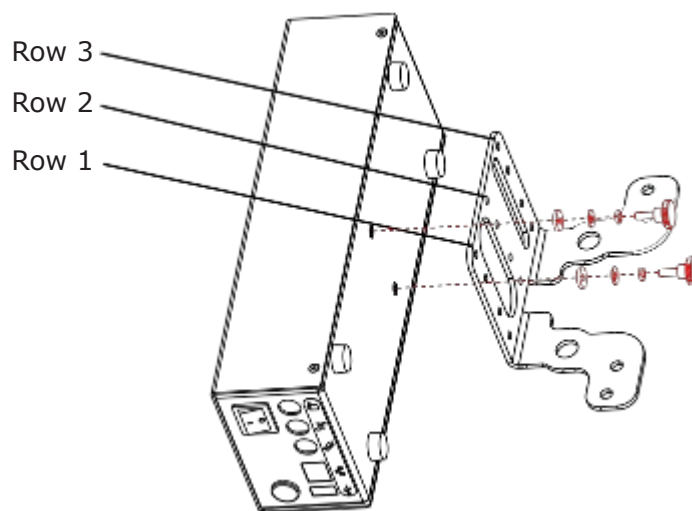

NOTE

To install the communication hub in alignment with the pump housing (the default position), use the holes in row 2. To install the hub toward the front of the isolator, use the holes in row 1. To install the hub toward the rear of the isolator, use the holes in row 3.

2. Use the large screws and washers to attach the holder to the bottom of the pump housing.

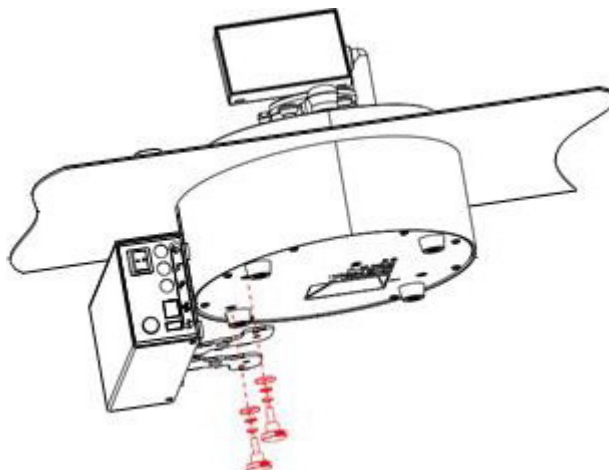

Installing to the Right of the Pump

1. Use the small screws and washers to attach the holder to the bottom of the communication hub.

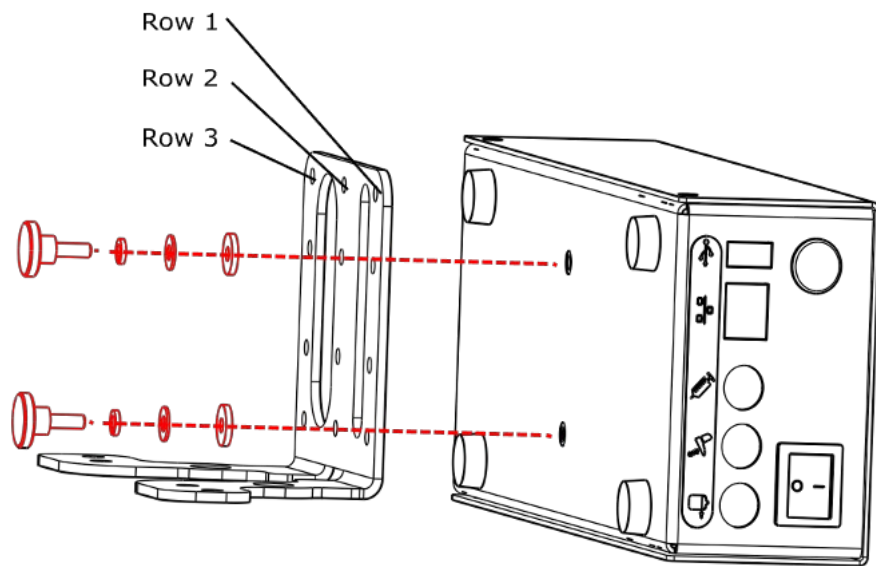

NOTE

To install the communication hub in alignment with the pump housing (the default position), use the holes in row 2. To install the hub toward the front of the isolator, use the holes in row 1. To install the hub toward the rear of the isolator, use the holes in row 3.

2. Use the large screws and washers to attach the holder to the bottom of the pump housing.

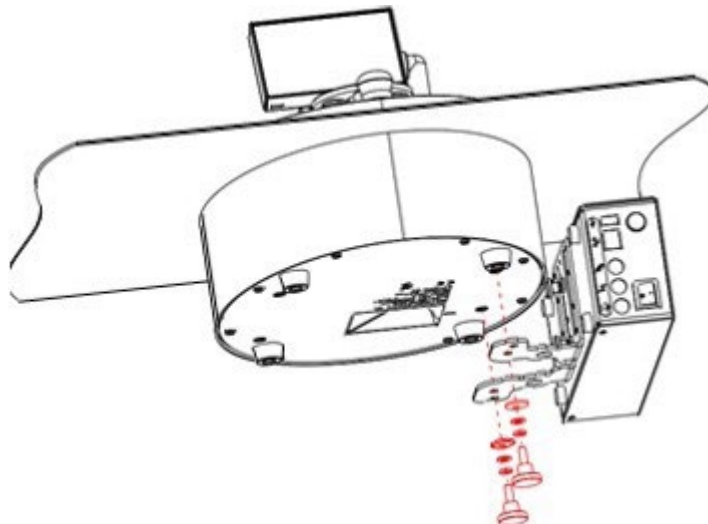

Installing the Communication Hub on the Side, Low Version

Installing to the Left of the Pump

1. Use the small screws and washers to attach the holder to the bottom of the communication hub.

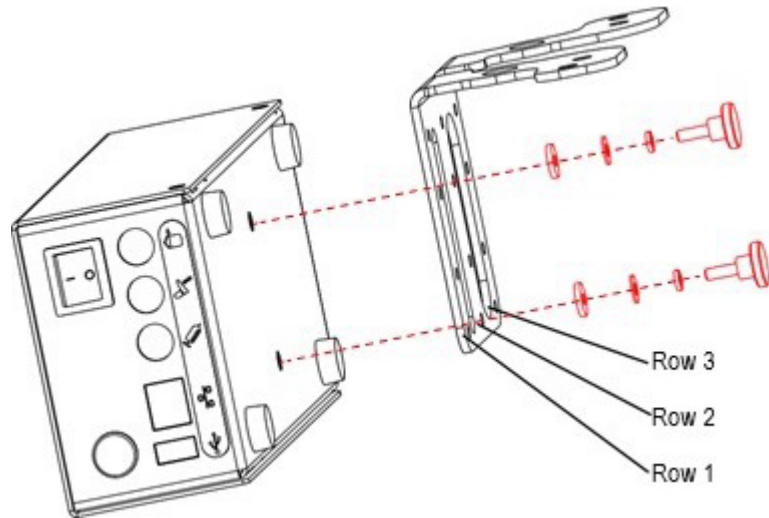

NOTE

To install the communication hub in alignment with the pump housing (the default position), use the holes in row 2. To install the hub toward the front of the isolator, use the holes in row 1. To install the hub toward the rear of the isolator, use the holes in row 3.

2. Use the large screws and washers to attach the holder to the bottom of the pump housing.

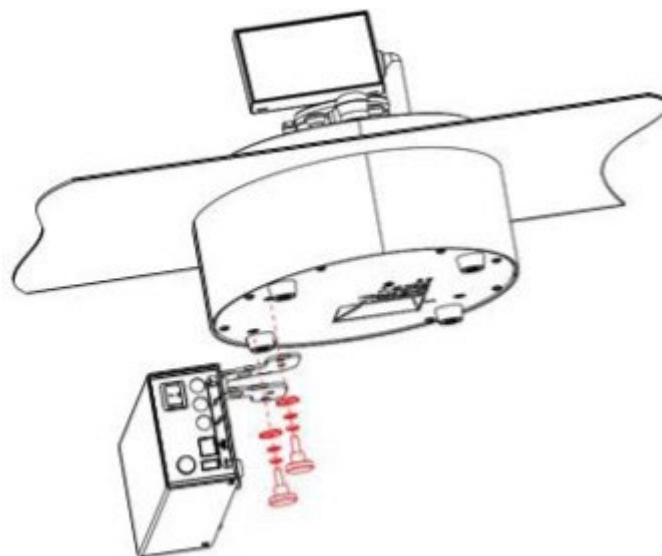

Installing to the Right of the Pump

1. Use the small screws and washers to attach the holder to the bottom of the communication hub.

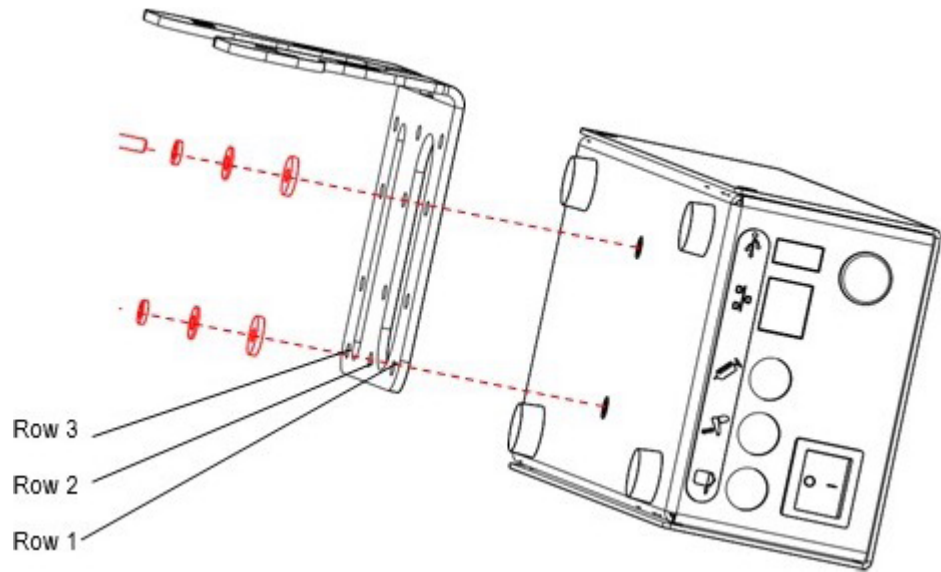

NOTE

To install the communication hub in alignment with the pump housing (the default position), use the holes in row 2. To install the hub toward the front of the isolator, use the holes in row 1. To install the hub toward the rear of the isolator, use the holes in row 3.

2. Use the large screws and washers to attach the holder to the bottom of the pump housing.

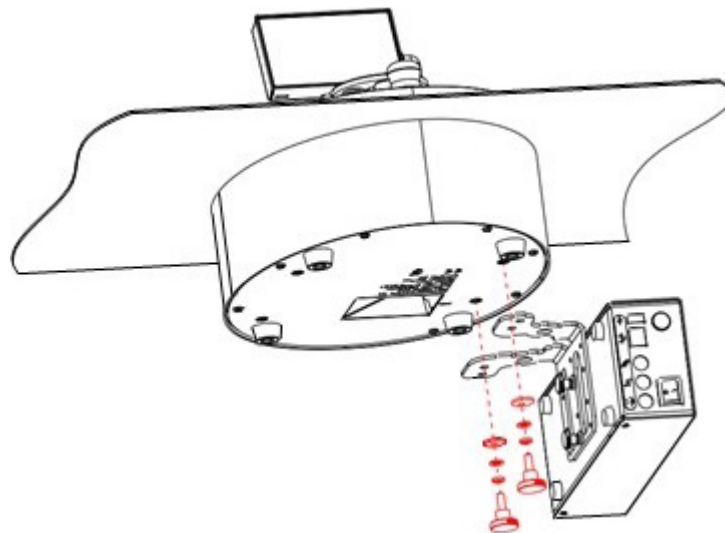

Installing the Communication Hub below the Pump Housing

1. Use the small screws and washers to attach the holder to the bottom of the communication hub.

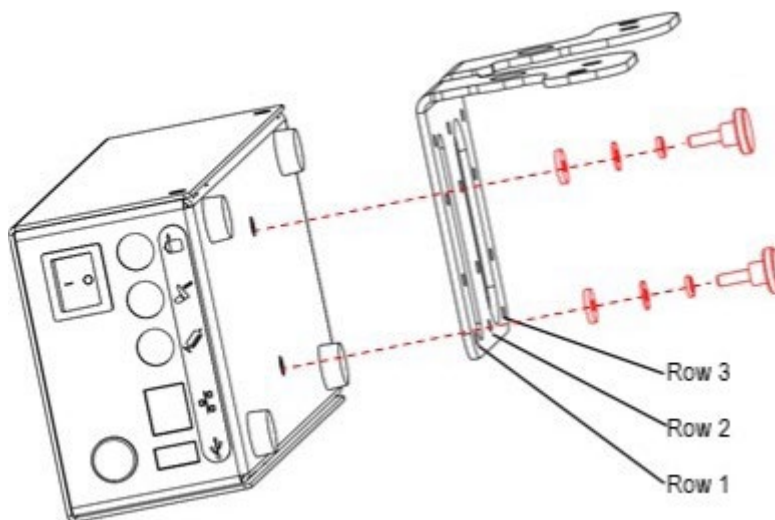

NOTE

To install the communication hub in alignment with the isolator (the default position), use the holes in row 2. To install the hub toward the front of the isolator, use the holes in row 1. To install the hub toward the rear of the isolator, use the holes in row 3.

2. Connect the end of the communication hub pump connection cord to the pump power inlet.
3. Use the large screws and washers to attach the holder to the bottom of the pump housing.

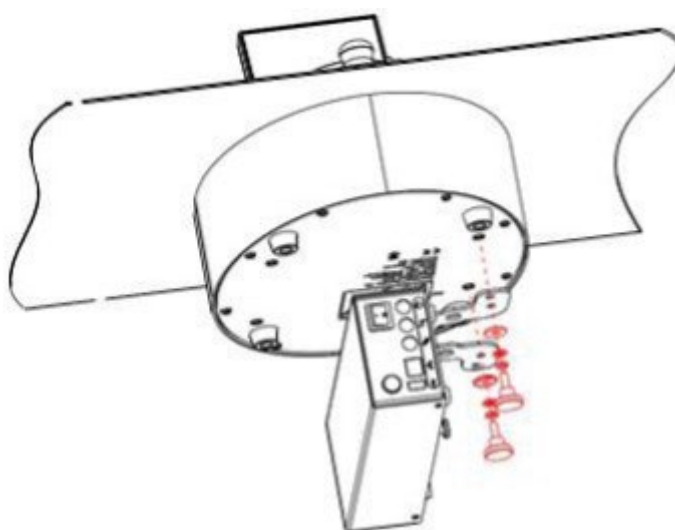

Installing the Pump in an Isolator: High Integration Configuration

NOTE

This procedure applies to isolator tables that are up to 7 mm thick. For thicker isolator tables, an adaptation kit is required. Contact our sales representative for more information.

Disassembling the Pump

1. Verify that the pump functions properly, and verify that the pump head is in its closed position (see Verifying that the Pump Functions Properly).
2. Retrieve the top wedging system from the packaging materials and place it on a flat, stable horizontal surface with the face in which the communication hub was located against the surface.
3. Turn the pump display to its transportation position (horizontal).
4. Turn the pump upside down and place it on the top wedging system.

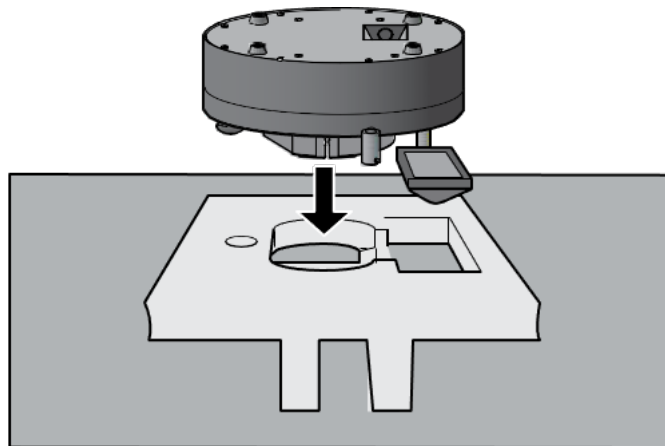

5. Locate the 8 screws that secure the pump bottom plate to the pump.

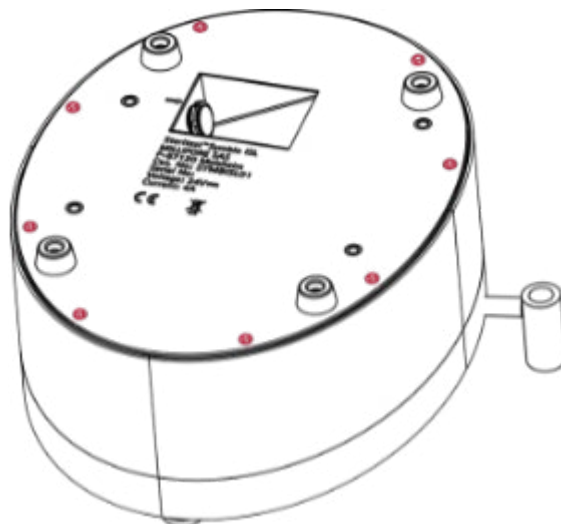

6. Use a T20 star screwdriver to remove the 8 screws.

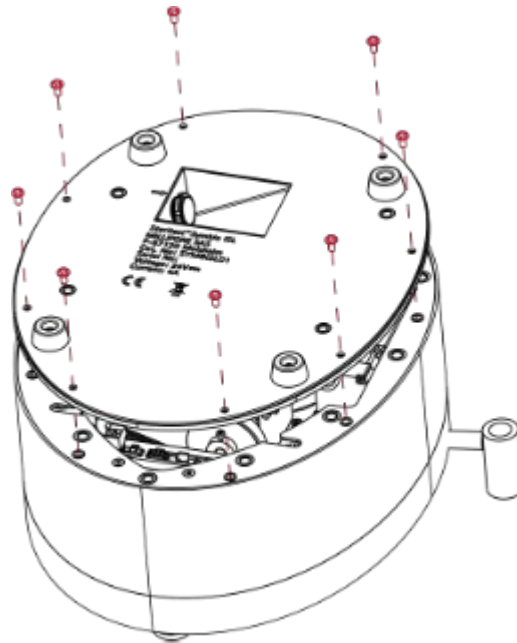

NOTE

The cable that connects the pump power inlet to the electronic board is attached to the pump bottom plate. It must be disconnected in order to remove the pump bottom plate.

7. Gently lift the pump bottom plate off the pump (1), disconnect the cable (2), and completely remove the bottom plate (3).

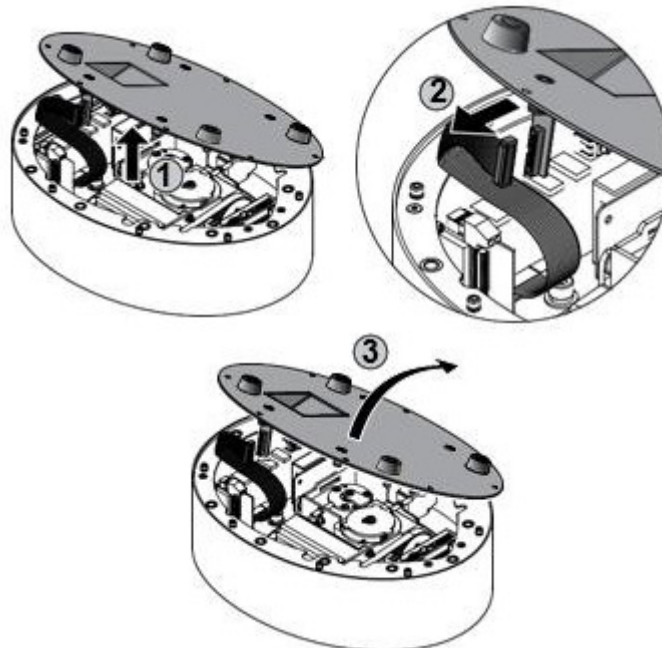

Installing the Pump in the Isolator

The Steritest® Symbio FLEX pump is compatible with standard round cutout (formerly used for the Steritest® Integral Pump and the Steritest® Equinox Isolator TQNXISL01 pump) and oval cutout (formerly used for the Steritest® Equinox Isofit pump).

Installing Using the Round Cutout

This procedure applies for the installation of a Steritest® Symbio FLEX pump on a new or existing standard round cutout. It also applies when a Steritest® Symbio FLEX pump replaces a Steritest® Integral Pump or a Steritest® Equinox Isolator TQNXISL01 pump.

To perform the installation, the Steritest® Symbio FLEX High Integration Kit for Round Cutout is required. This kit is not delivered with the Steritest® Symbio FLEX Pump (see Accessories and Replacement Parts). This kit contains:

- An upper adapter ring
- 10 M8 screws to attach the upper ring to the pump housing
- A lower adapter ring
- 6 M8 screws to attach the lower adapter ring to the upper adapter ring through the isolator table
- A special bottom plate
- 6 M4 screws to attach the bottom plate to the lower adapter ring
- A flat seal
- A special wrench
- A special drain tray support for high integration

NOTE

The upper adapter ring, the lower adapter ring, and bottom plate are delivered assembled together, using some of the screws listed above.

1. Locate the 6 screws that secure the bottom plate to the lower adapter ring.

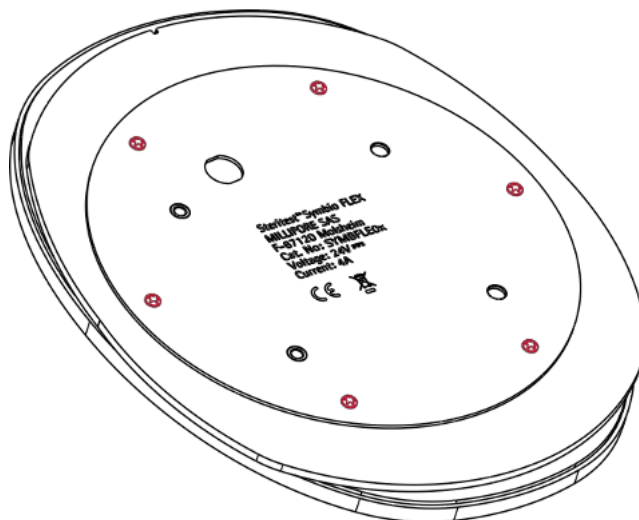

2. Use a T20 star screwdriver to remove these 6 screws.

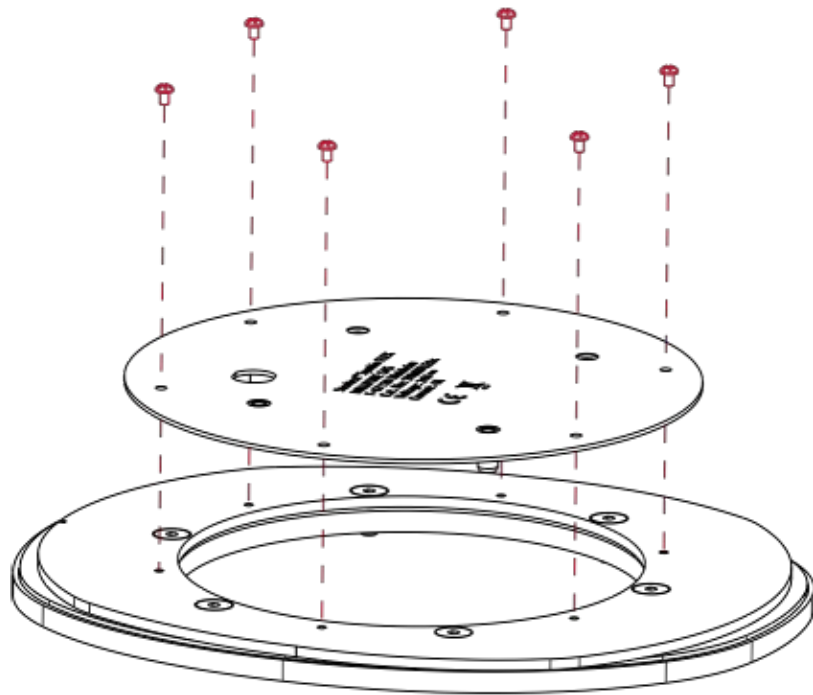

3. Locate the 6 screws that secure the lower adapter ring to upper adapter ring.

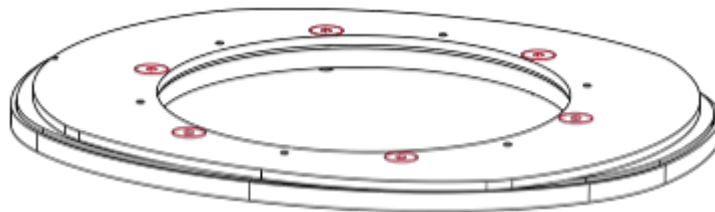

4. Use a #5 hex key to remove these 6 screws.

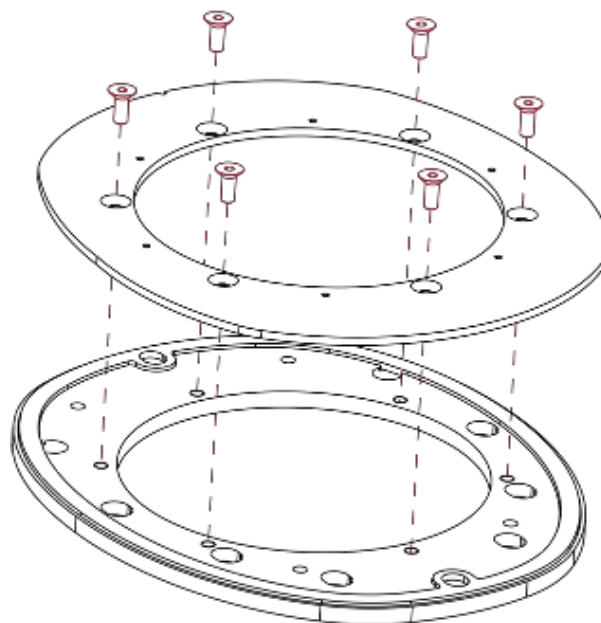

5. Remove the adhesive protector from the flat seal and place it at the top of the pump housing as shown in the following drawing.

NOTE

The seal delivered with the pump (in the accessories package) can also be used.

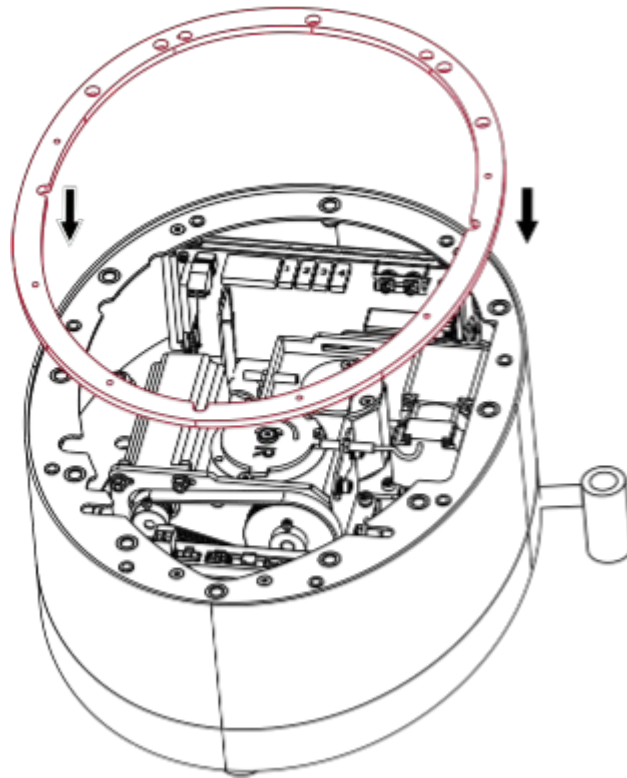

6. Place the upper adapter ring seal on the top of the pump housing.

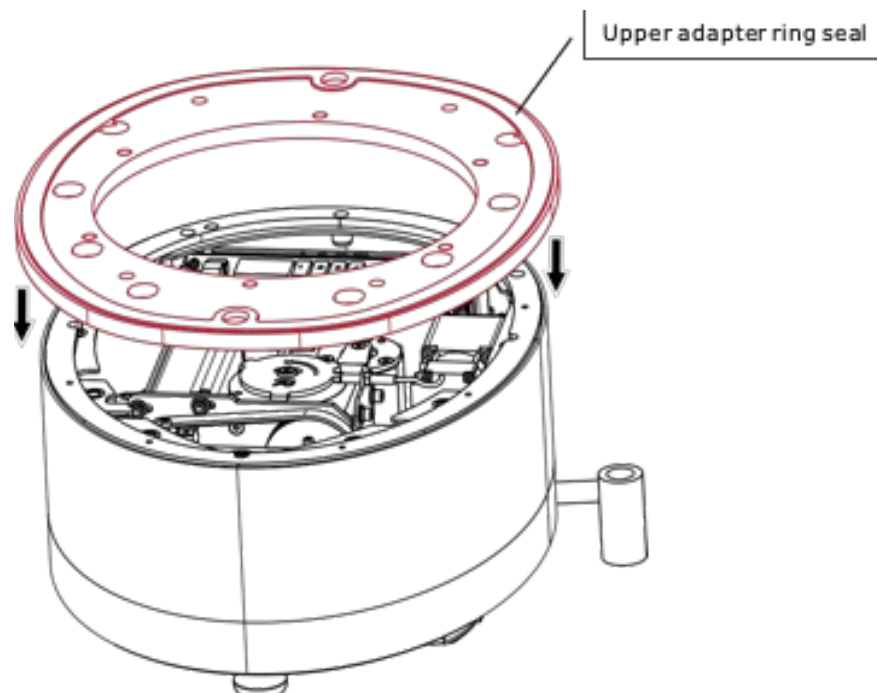

7. Use a #6 hex key to install the 10 screws that attach the upper adapter ring to the pump housing.

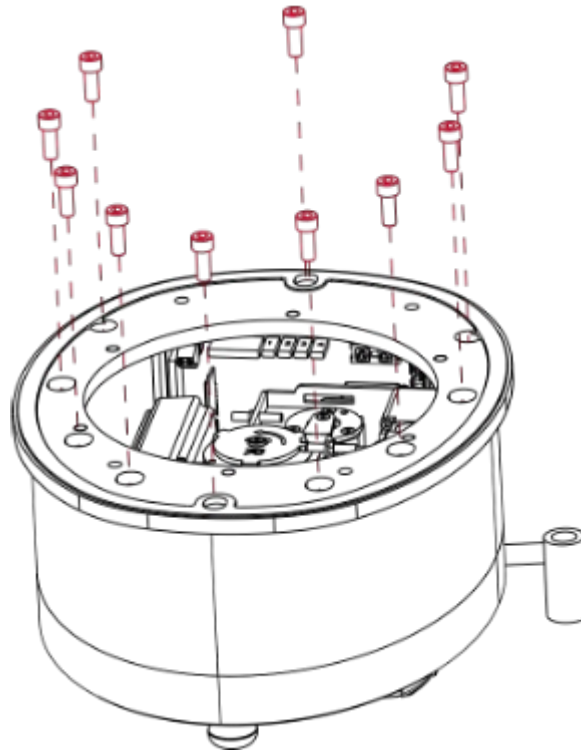

NOTE

Ensure that all the screws are fully tightened to ensure tightness of the pump.

8. Insert the two threaded stems into the two M8 holes indicated in the following drawing.

NOTE

The threaded stems are delivered with the pump in the accessories package.

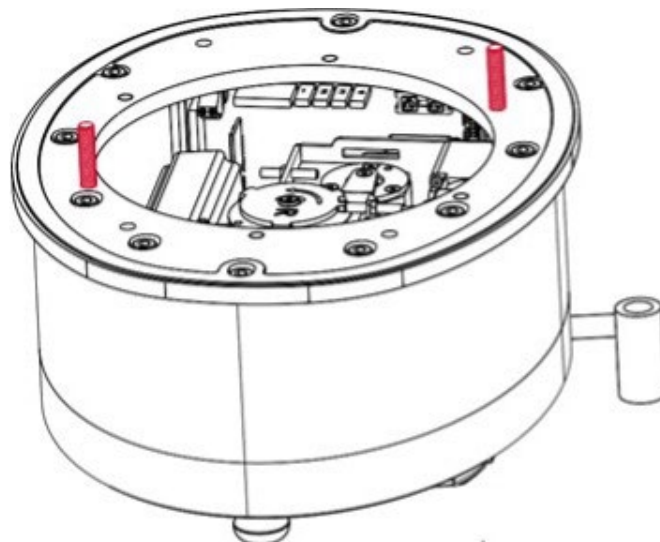

9. Turn the pump right side up and place it above the isolator cutout.

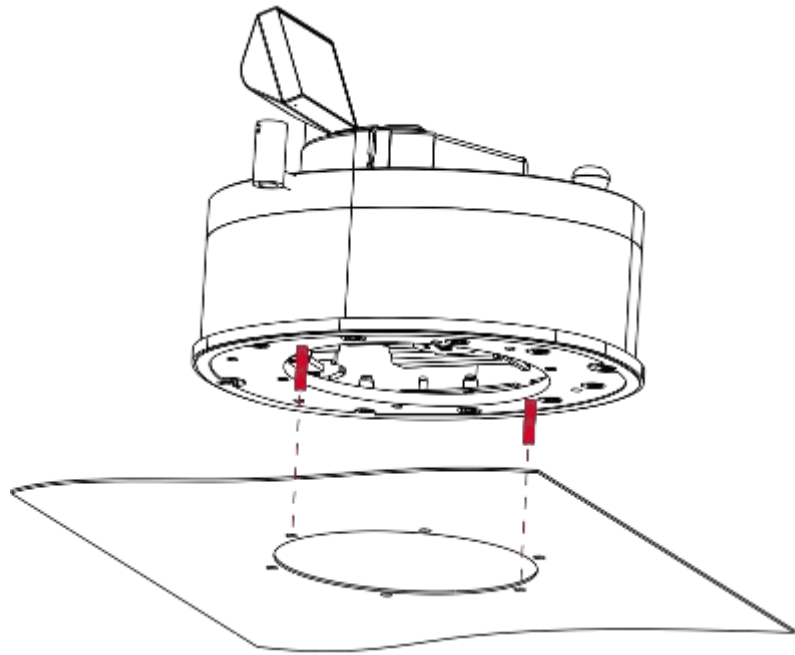

10. Center the pump by placing the two threaded stems in the dedicated holes of the cutout.

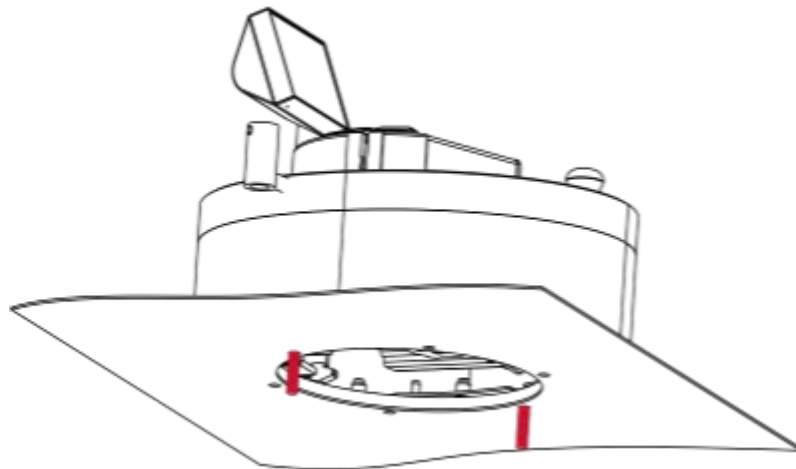

11. Place the lower ring below the isolator table as shown on the following drawing:

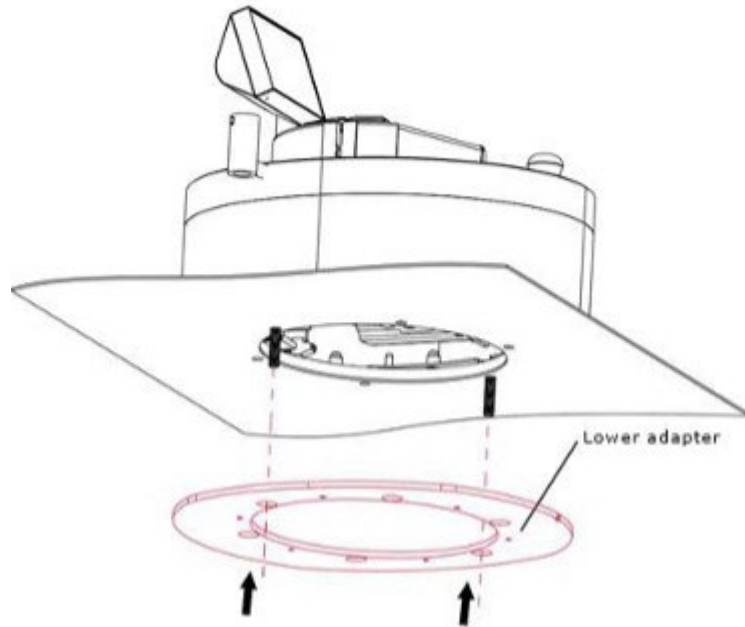

12. Use a #5 hex key to install 4 of the 6 screws that attach the lower adapter ring to the isolator table.

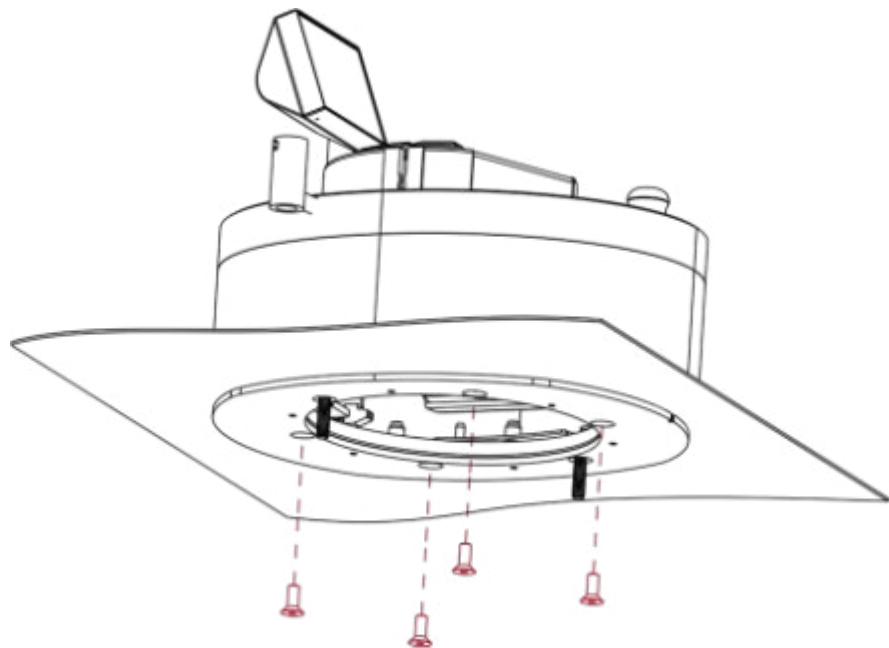

13. Remove the two threaded stems.

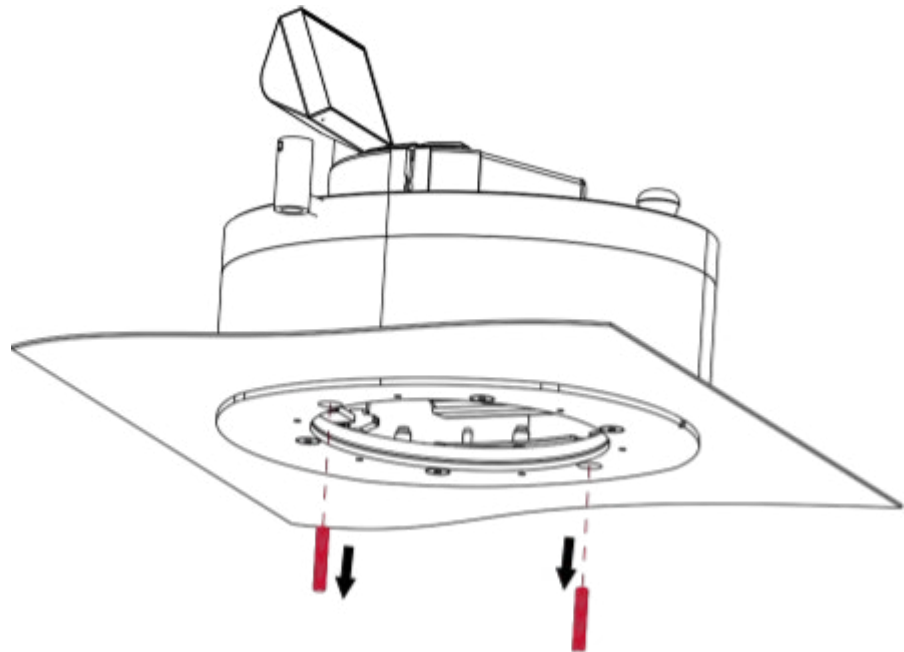

14. Use a #5 hex key to install 2 remaining screws that attach the lower adapter ring to the isolator table.

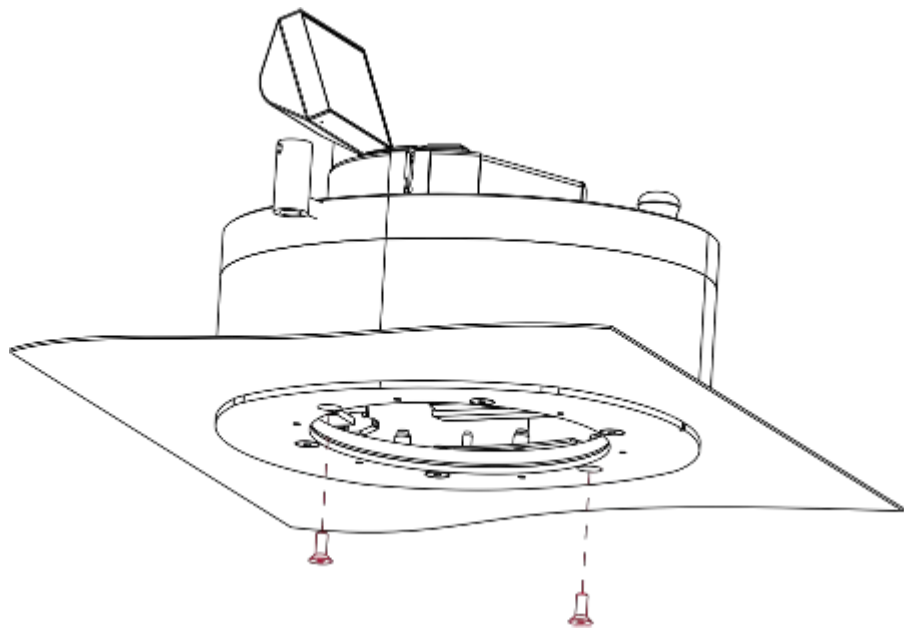

15. Retrieve the original pump bottom plate that was delivered with the pump.

16. Hold the power connector and use the special wrench delivered with the integration kit to unscrew the power connector nut.

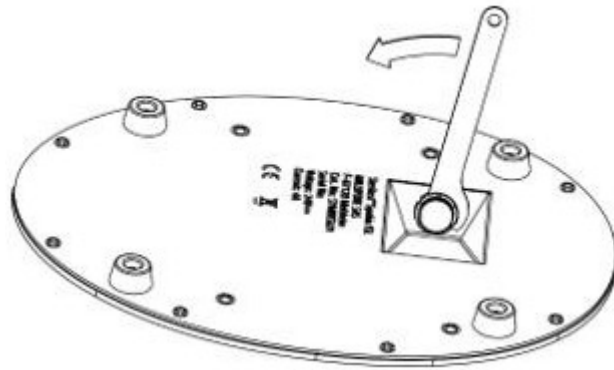

17. Remove the power connector nut.

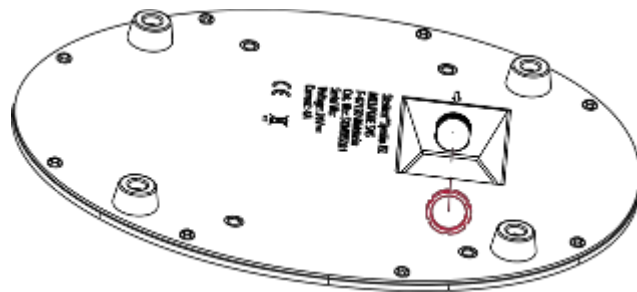

18. Remove the power connector with its O-ring from the bottom plate.

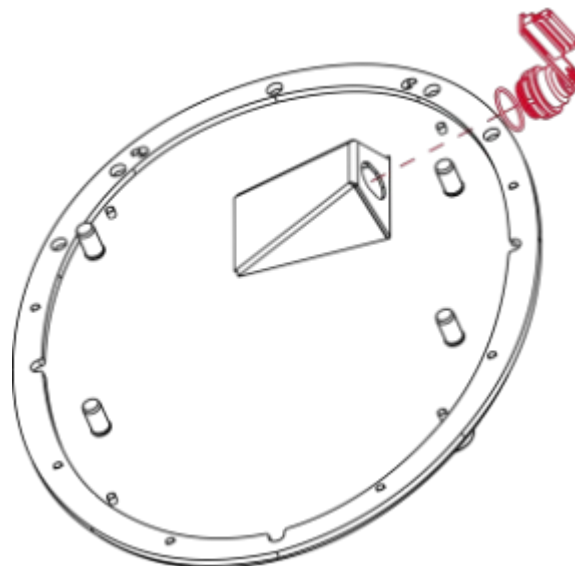

19. Insert the power connector with its O-ring through the hole on the bottom plate that was delivered with the integration kit.

NOTE

Maintain the orientation of the connector as shown in the following drawings.

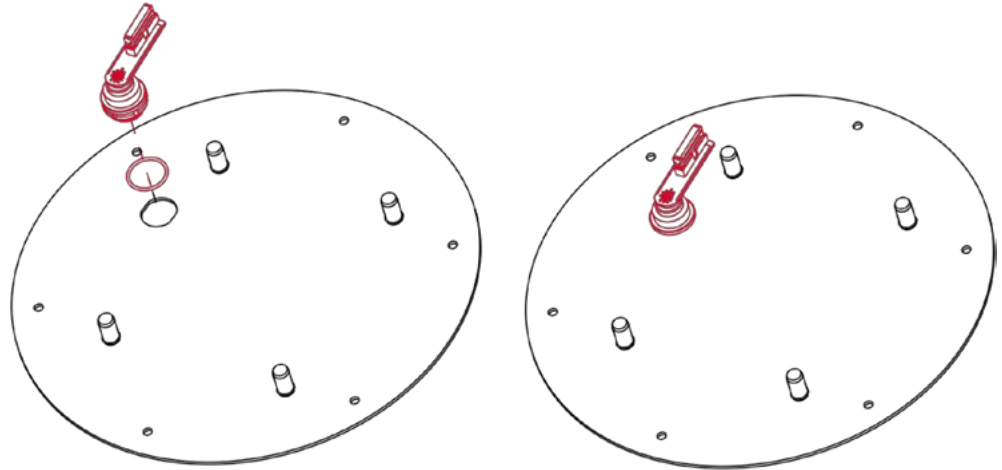

20. Place the power connector nut on the power connector.

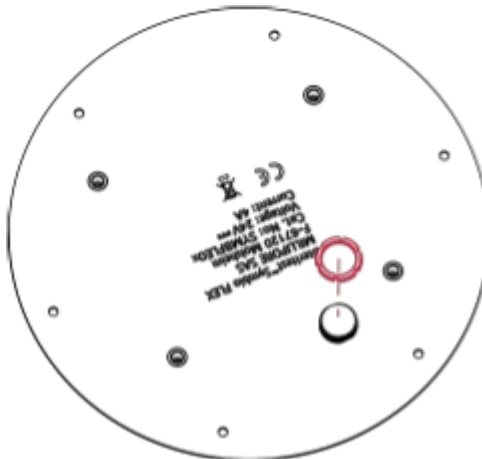

21. Hold the power connector and use the special wrench to fasten the power connector nut.

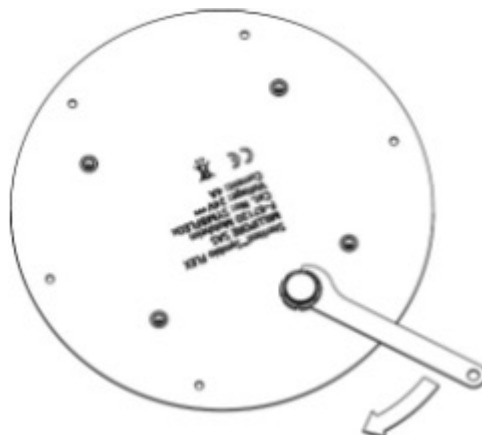

22. In the bottom plate that was delivered with the integration kit underneath the pump housing.

NOTE

Maintain the orientation of the bottom plate as shown in the following drawings.

23. Connect the power connector cable to the power connector located on the bottom plate, and then place the bottom plate under the pump housing.

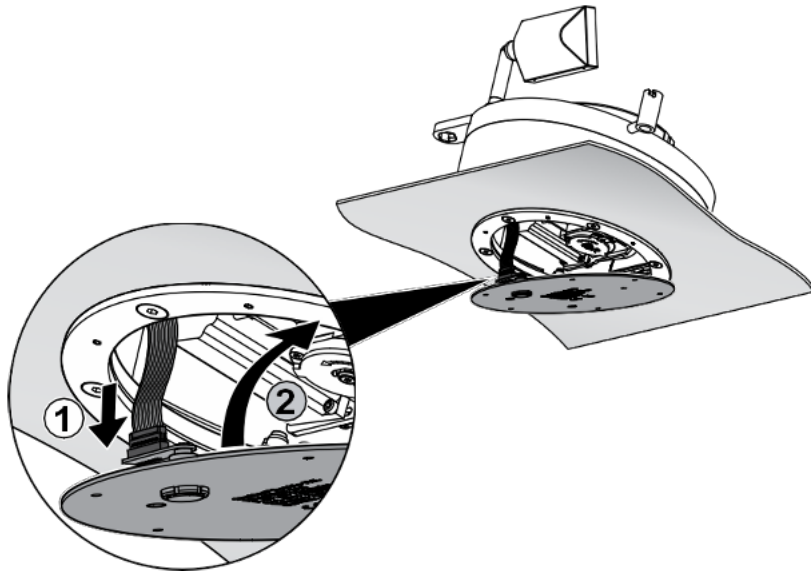

24. Use a T20 star screwdriver to install the 6 screws that attach the bottom plate to the lower adapter ring.

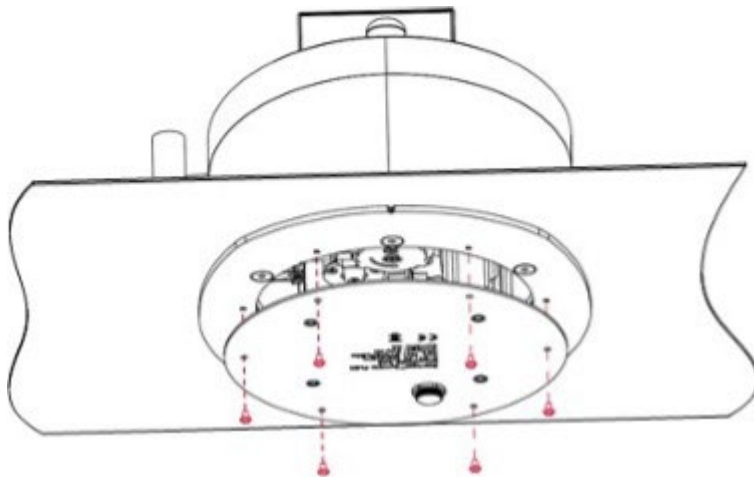

NOTE

In this configuration, the standard pump bottom plate and its 8 screws remain unused at the end of the installation.

25. Connect the communication hub pump connection cord to the pump power inlet.
26. Connect the communication hub to power source using the power cord delivered with the pump.

NOTE

The communication hub can be installed under the isolator using the optional communication hub holder for isolator (See Installing the Communication Hub under the Isolator: High Integration. It can also be fixed to one of the isolator feet, using the optional communication hub holder for hoods (see Accessories and Replacement Parts).

27. Switch on the communication hub by pressing the on/off switch (position I).

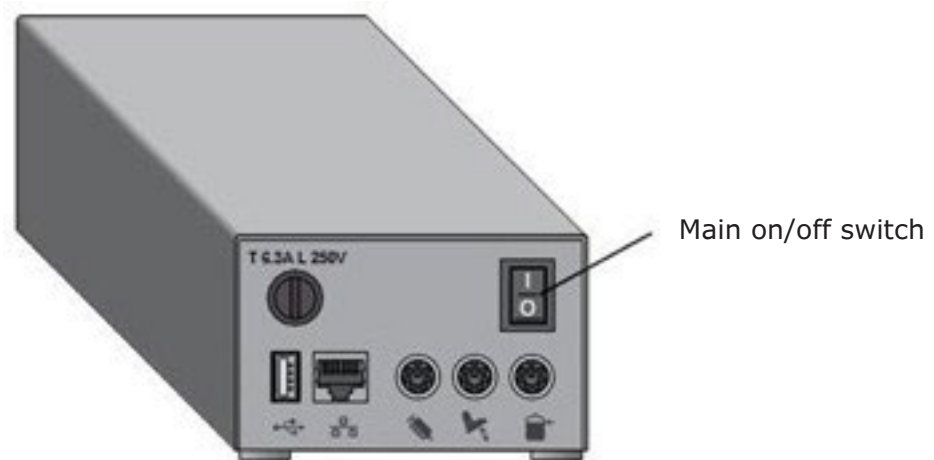

28. Verify that the pump functions properly (see Tests After Installation).
29. Replace the drain tray support delivered with the pump (in the accessories package) with the one contained in the integration kit.

Installing Using the Oval Cutout

This procedure applies when a Steritest® Symbio FLEX pump replaces a Steritest® Equinox Isofit pump.

To perform the installation, the Steritest® Symbio FLEX High Integration Kit for Oval Cutout is required. This kit is not delivered with the Steritest® Symbio FLEX Pump (see Accessories and Replacement Parts). This kit contains:

- An adapter ring
- 10 screws to attach the adapter ring to the pump through the isolator table
- A flat seal
- A special drain tray support for high integration

1. Remove the adhesive protector from the flat seal and place it at the top of the pump housing as shown in the following drawing (the seal delivered with the pump can also be used).

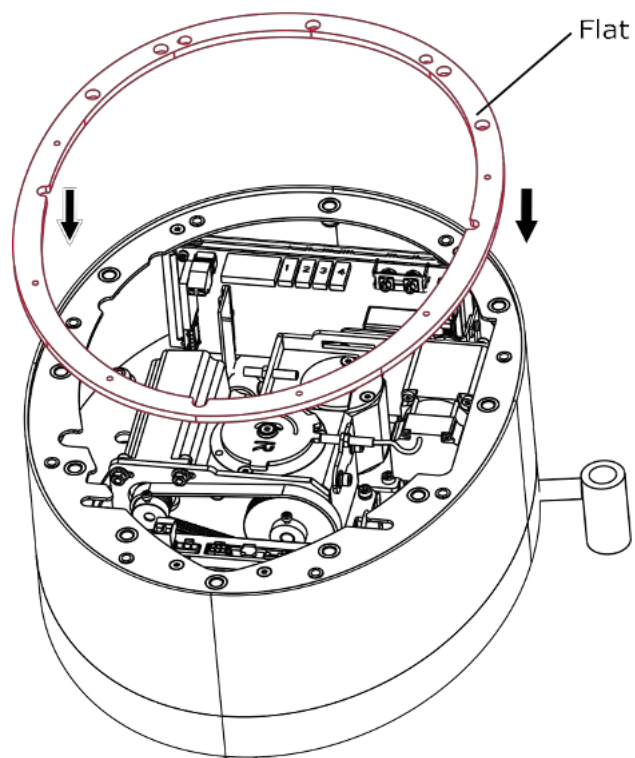

2. Insert the two threaded stems into the two M8 holes indicated in the following drawing:

NOTE

The threaded stems are delivered with the pump in the accessories package.

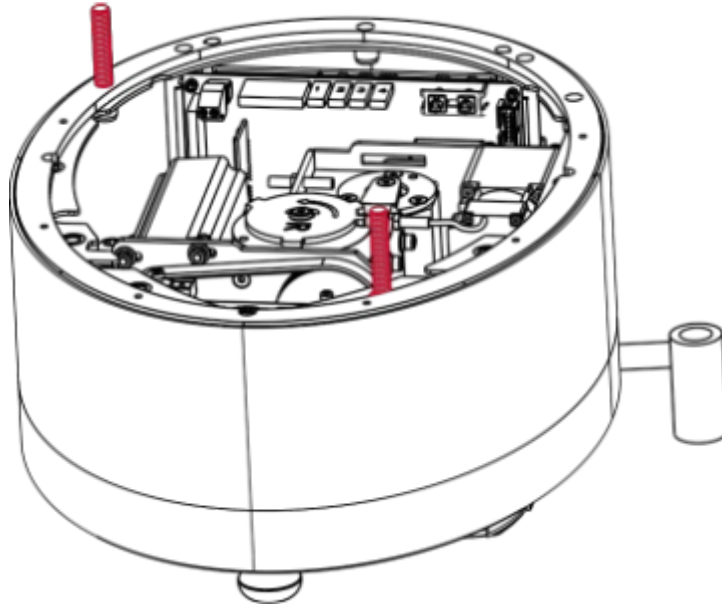

3. Turn the pump right side up and place it above the isolator cutout.

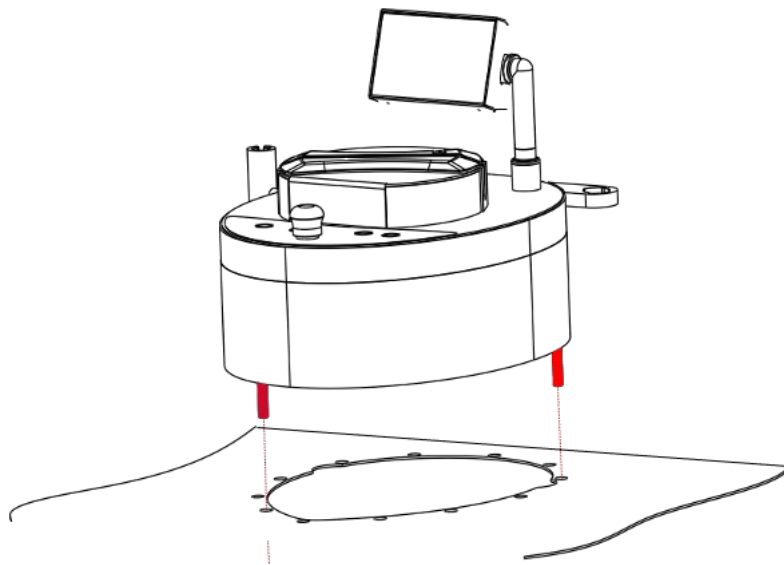

- Center the pump by placing the two threaded stems in the dedicated holes of the cutout.

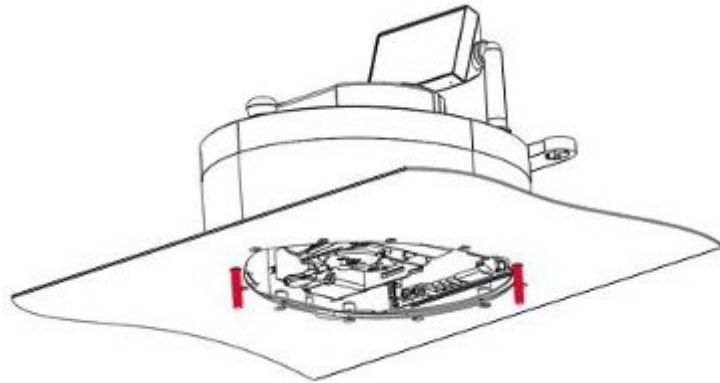

- Place the adapter ring below the isolator table as shown on the following drawing:

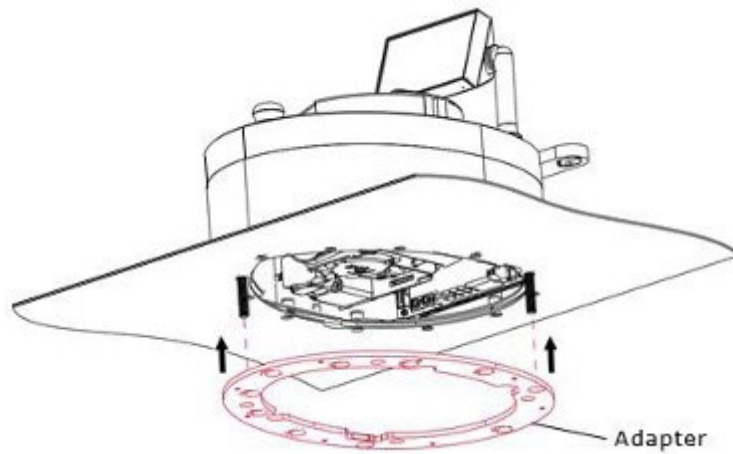

- Use a #5 hex key to install 8 of the 10 screws that attach the adapter ring to the pump through the isolator table.

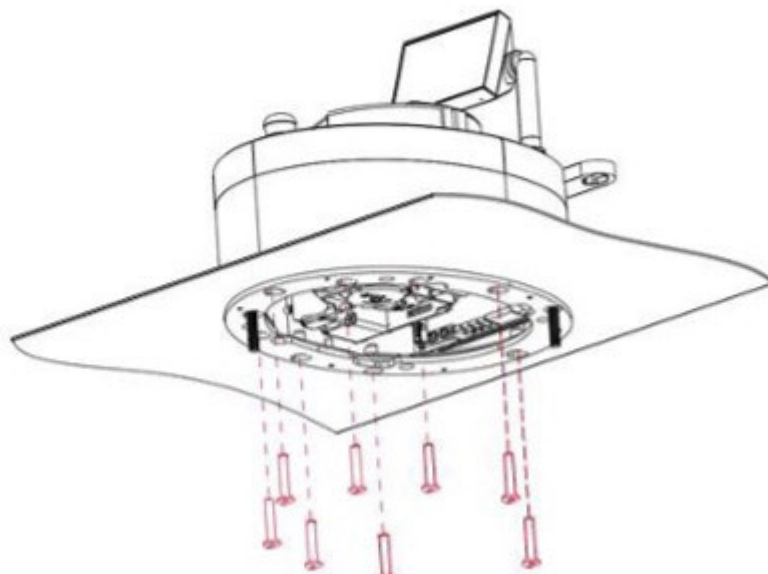

7. Remove the two threaded stems.

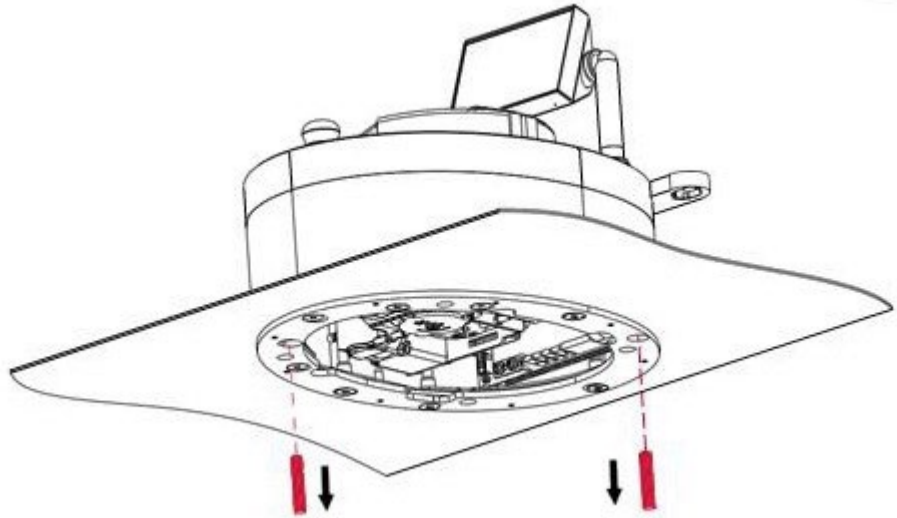

8. Use a #5 hex key to install 2 remaining screws that attach the adapter ring to the isolator table.

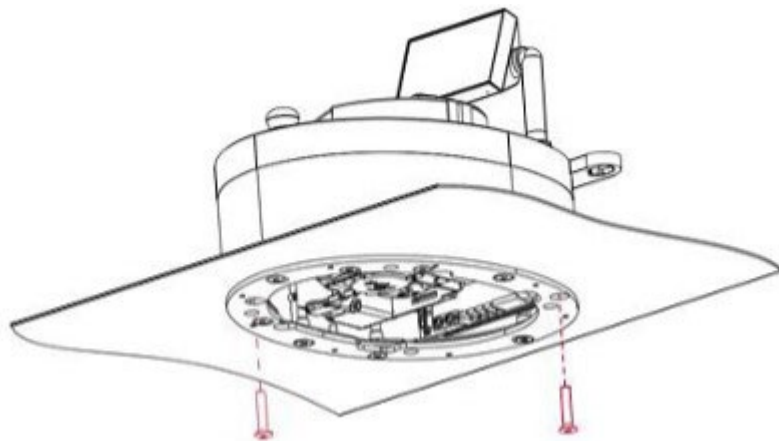

9. Position the pump bottom plate underneath the pump housing.
10. Connect the power connector cable to the power connector located on the bottom plate, and then place the bottom plate under the pump housing.

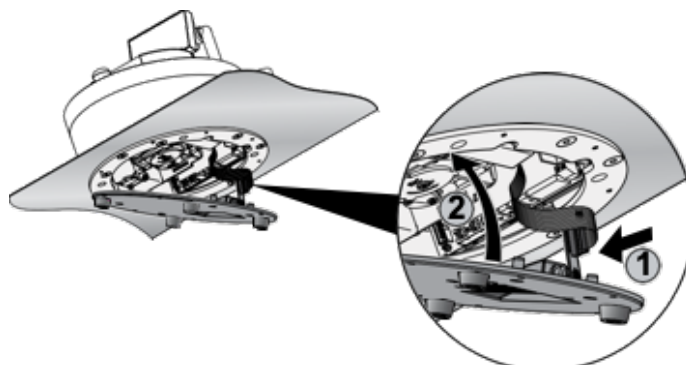

11. Use a T20 star screwdriver to install the 8 screws that attach the bottom plate to the adapter ring.

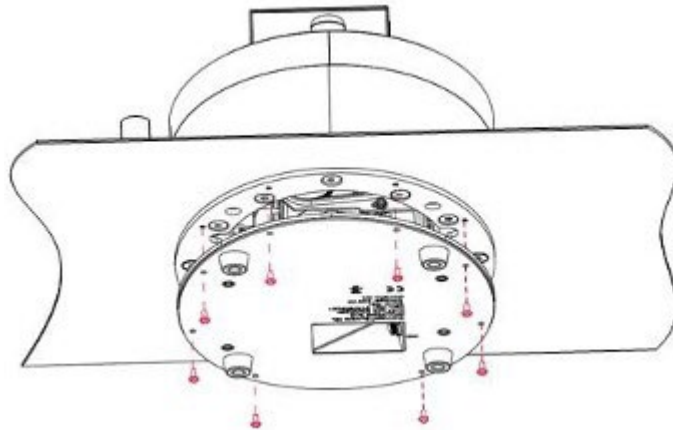

12. Connect the communication hub pump connection cord to the pump power inlet.
13. Connect the communication hub to power source using the power cord delivered with the pump.

NOTE

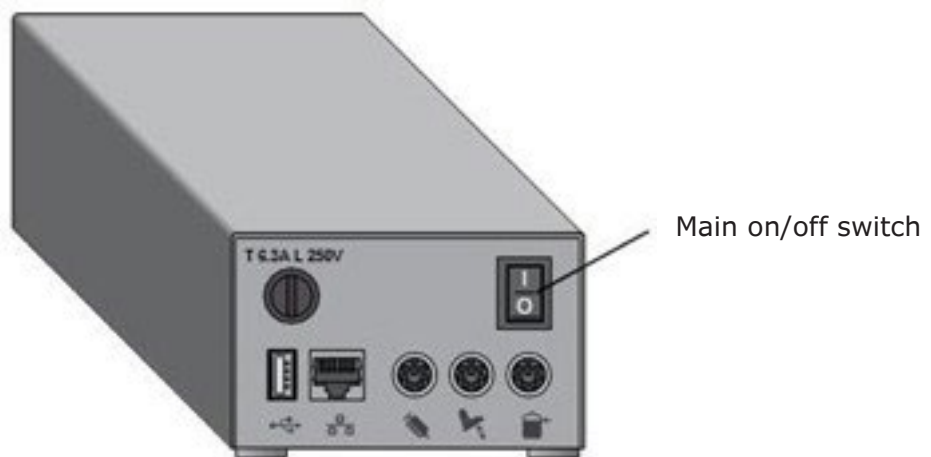

The communication hub can be installed under the isolator using the optional communication hub holder for isolator (See Installing the Communication Hub under the Isolator: High Integration). It can also be fixed to one of the isolator feet, using the optional communication hub holder for hoods (see Accessories and Replacement Parts.)

14. Switch on the communication hub by pressing the on/off switch (position I).



15. Verify that the pump functions properly (see Tests After Installation).

Tests After Installation

1. Simultaneously press and hold the pump on/off  and the open/close  buttons. The screen displays the range of Steritest® devices. This is followed by the welcome screen:



2. After a few seconds, the following screen displays:



3. When the autotest is complete, the following screen displays. A ✓ symbol in a check box indicates that an accessory or data source is connected to the communication hub.

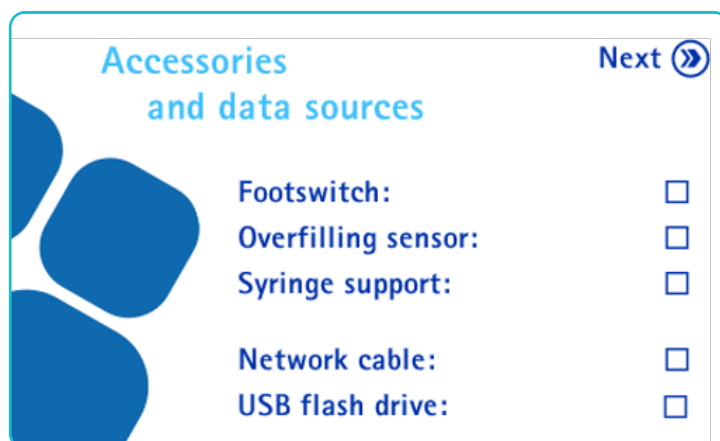

4. Press the  button. The installation menu displays.

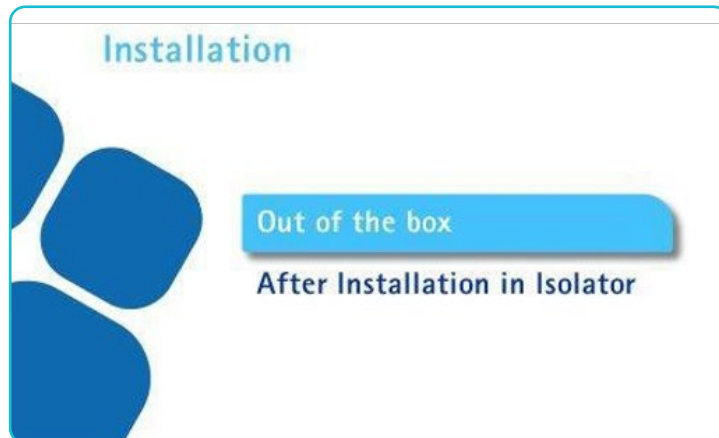

5. Turn the control knob to select **After Installation in Isolator**.

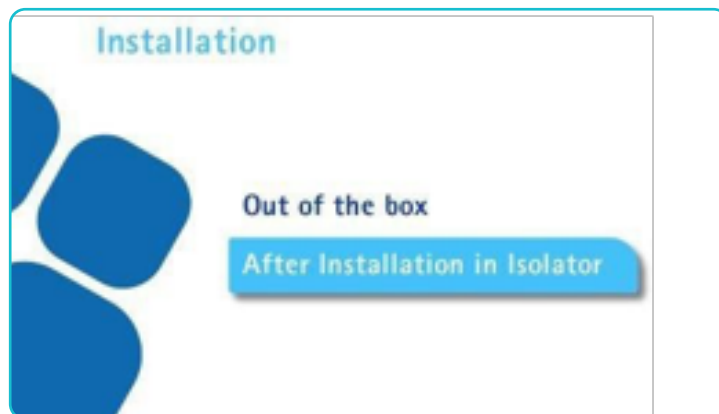

6. Press the control knob. The **After Installation in Isolator** screen displays.

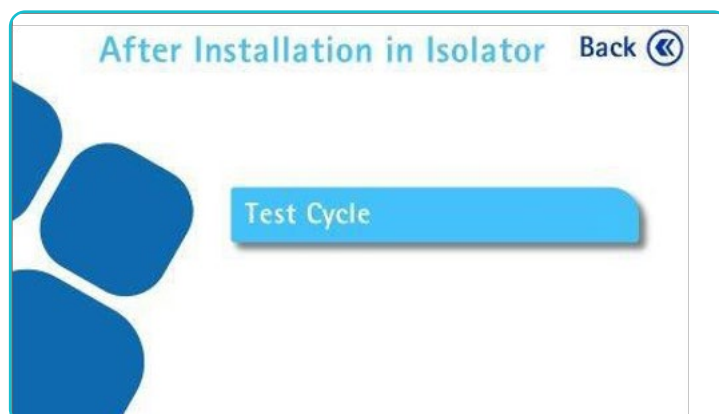

7. Press the control knob to begin the test cycles. Three cycles will be performed.

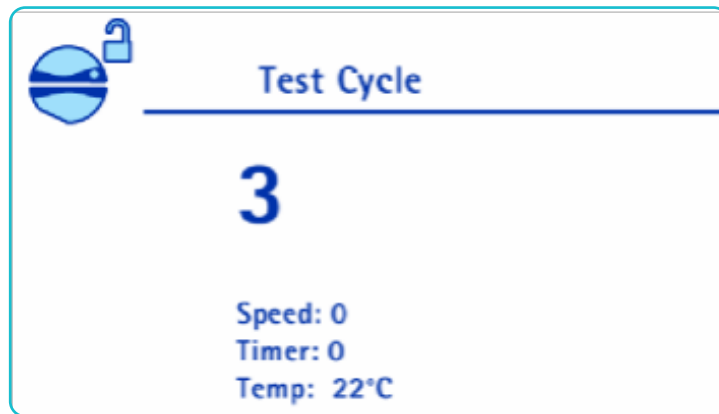

8. After the pump head closes, the pump starts automatically and 3 test cycles are performed.

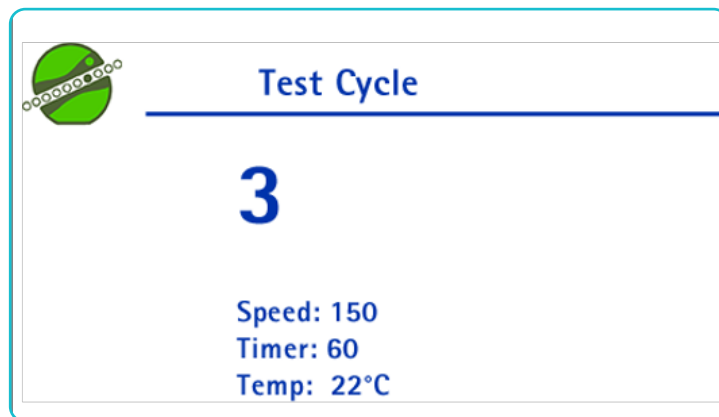

9. When the test cycles complete with no error, the following screen displays.



10. Switch off the communication hub by pressing the on/off switch (position O). The Shutdown screen displays.



11. Disconnect the communication hub pump connection cord from the pump power inlet.
12. Replace the drain tray support delivered with the pump (in the accessories package) with the one contained in the integration kit.

Installing the Communication Hub under the Isolator: High Integration

Use the optional communication hub holder for isolators to install the communication hub under the isolator table (see Accessories and Replacement Parts). Multiple configurations are possible. This procedure applies for both round and oval cutouts.

Installing the Communication Hub to the Left of the Pump

1. Use the small screws and washers to attach the holder to the bottom of the communication hub.

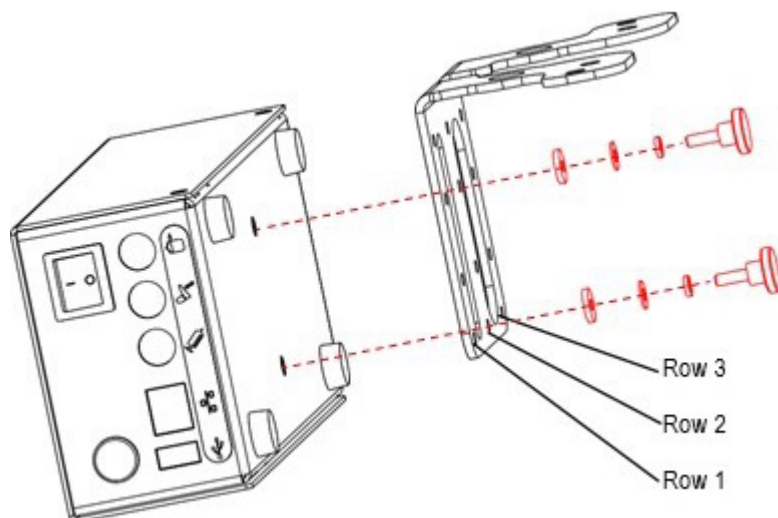

NOTE

To install the communication hub in alignment with the pump housing (the default position), use the holes in row 2. To install the hub toward the front of the isolator, use the holes in row 1. To install the hub toward the rear of the isolator, use the holes in row 3.

2. Use the large screws and washers to attach the holder to the bottom of the pump housing.

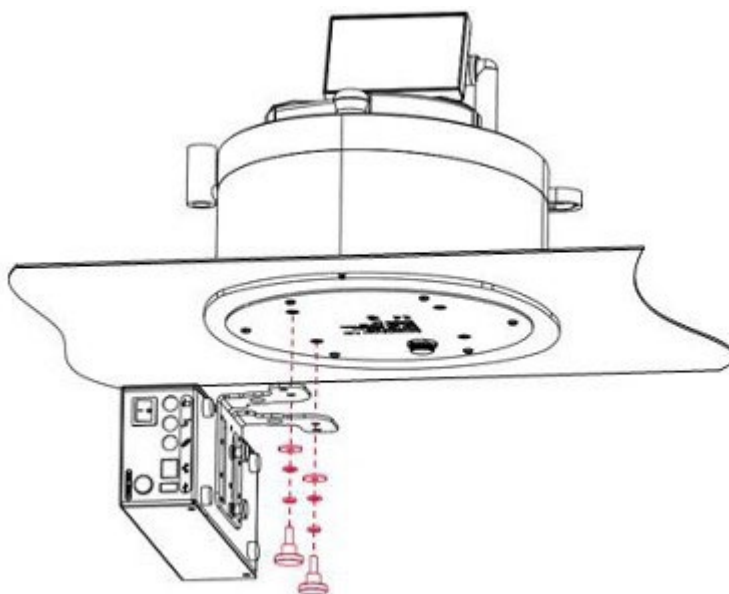

Installing the Communication Hub to the Right of the Pump

1. Use the small screws and washers to attach the holder to the bottom of the communication hub.

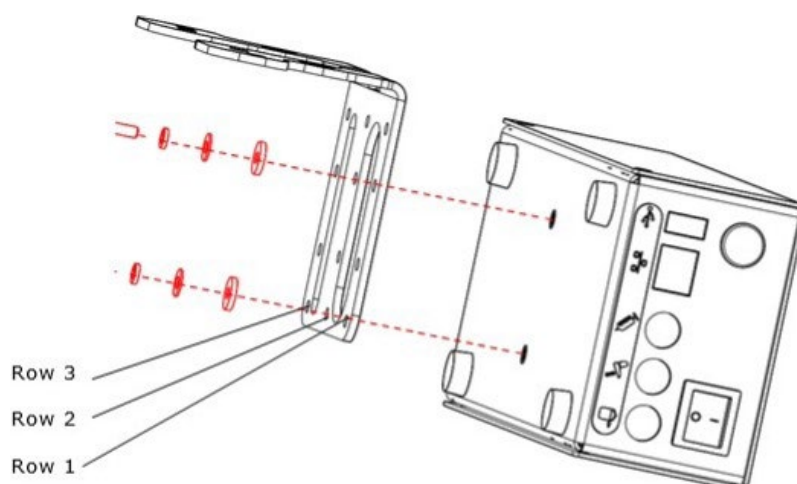

NOTE

To install the communication hub in alignment with the pump housing (the default position), use the holes in row 2. To install the hub toward the front of the isolator, use the holes in row 1. To install the hub toward the rear of the isolator, use the holes in row 3.

2. Use the large screws and washers to attach the holder to the bottom of the pump housing.

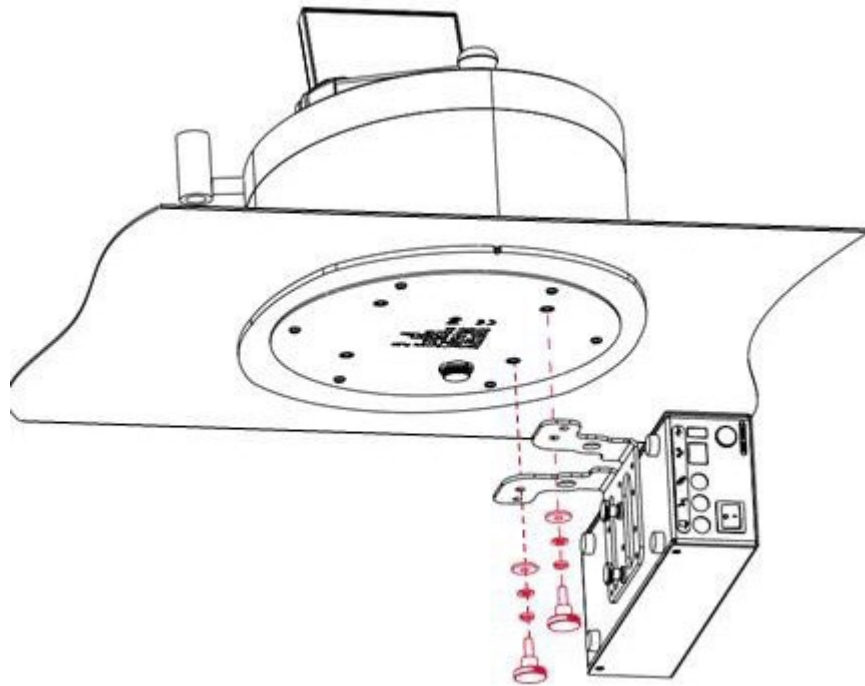

Installing the Communication Hub Centered under the Pump

1. Use the small screws and washers to attach the holder to the bottom of the communication hub.

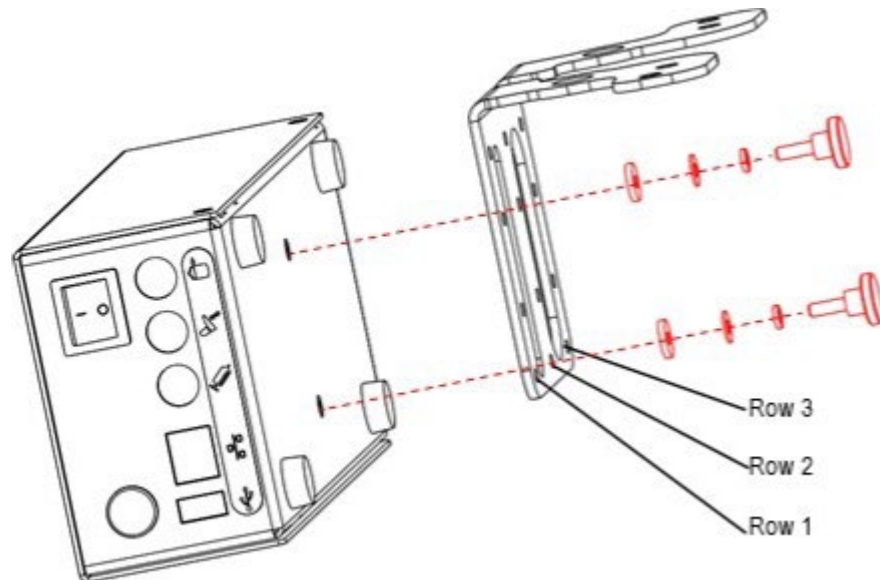

NOTE

To install the communication hub in alignment with the isolator (the default position), use the holes in row 2. To install the hub toward the front of the isolator, use the holes in row 1. To install the hub toward the rear of the isolator, use the holes in row 3.

2. Connect the end of the communication hub pump connection cord to the pump power inlet.
3. Use the large screws and washers to attach the holder to the bottom of the pump housing.

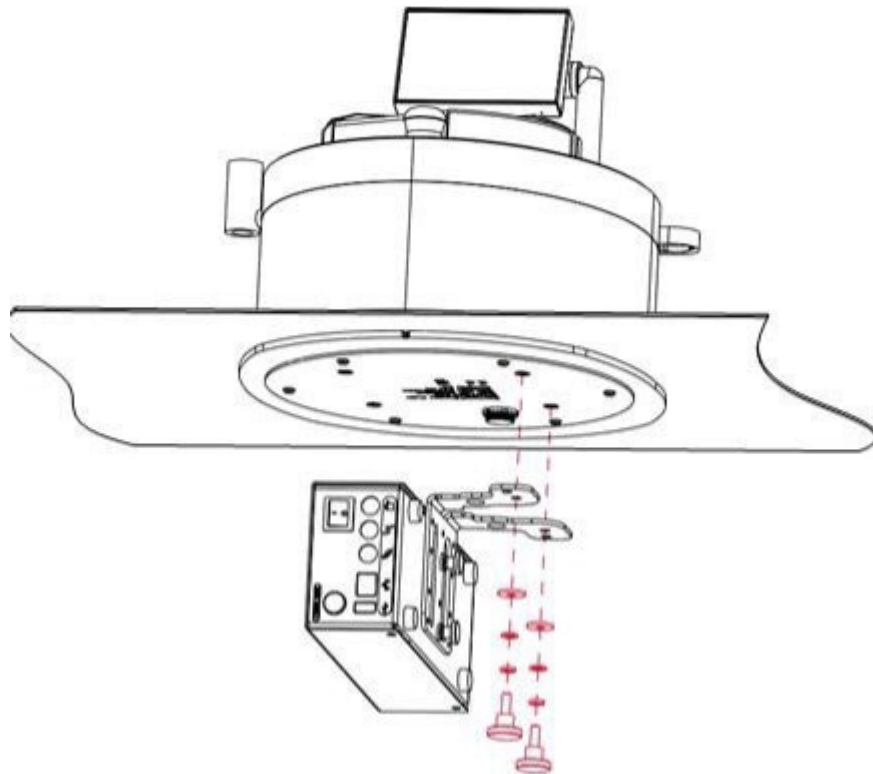

Installing the Pump in an Isolator: on Feet

To install the pump directly on its feet in an isolator, the standard pump feet must be replaced by the special feet for use in isolator, and the Steritest® Symbio connection cable extension with Tri-Clover® clamp must be used to connect the pump to the communication hub (see Accessories and Replacement Parts).

1. Verify that the pump functions properly and verify that the pump head is in its closed position (see Tests After Installation).
2. Retrieve the top wedging system from the packaging materials and place it on a flat, stable horizontal surface with the face in which the communication hub was located against the surface.
3. Turn the pump display to its transportation position (horizontal).

4. Turn the pump upside down and place it on the top wedging system.

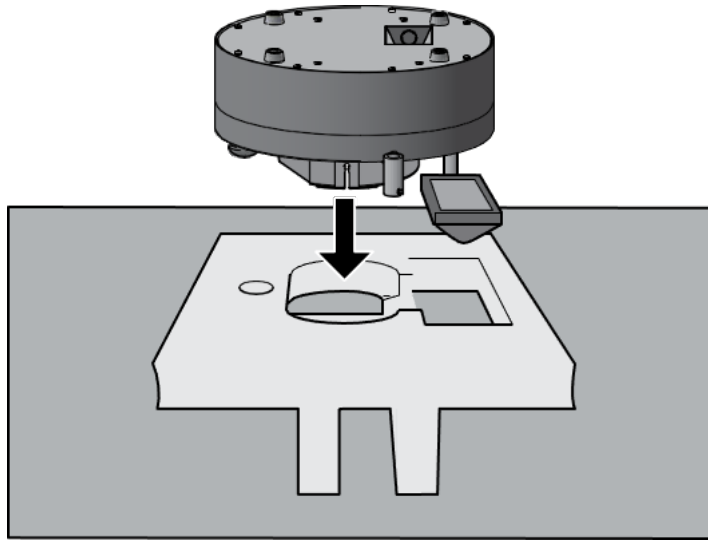

5. Use a T20 star screwdriver to remove the screws that attach the standard feet to the pump bottom plate.

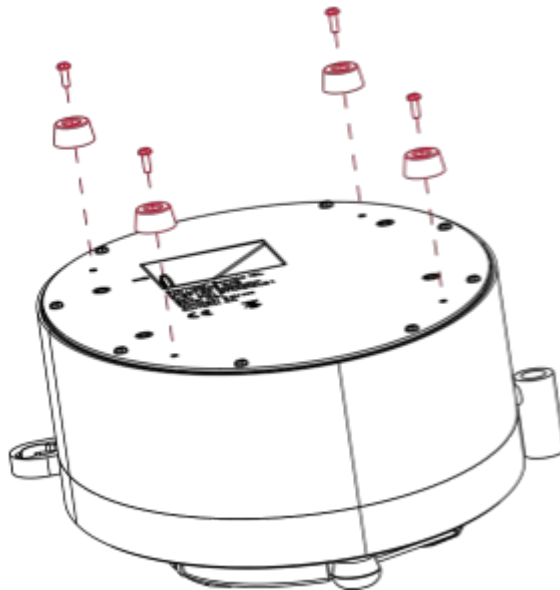

6. Use a #13 wrench to fasten the special feet for use in isolator to pump bottom plate.

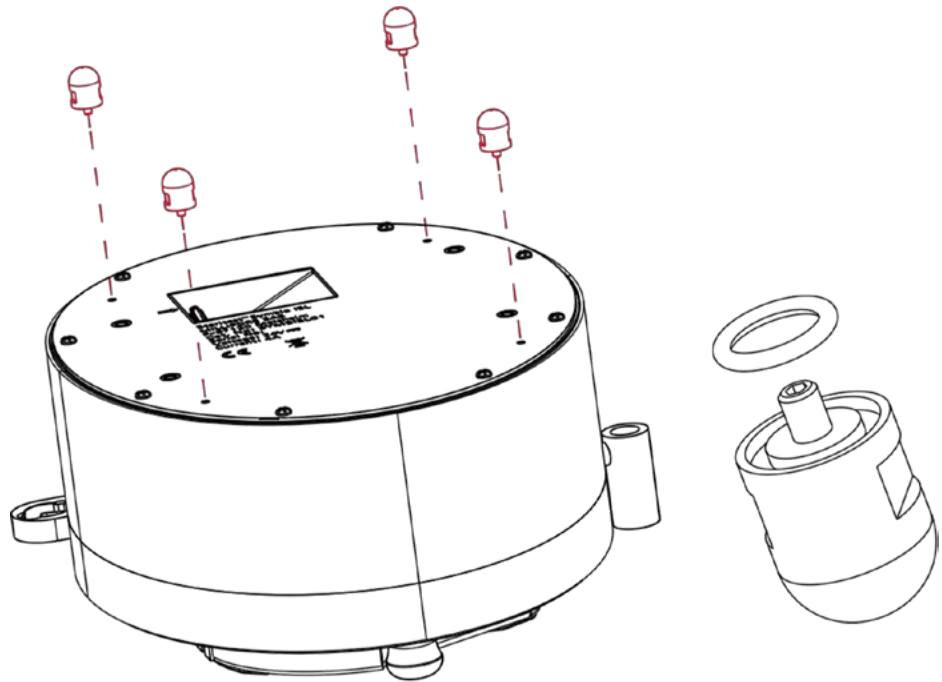

7. Turn the pump right side up and place it in the isolator.

NOTE

Use the optional carrying handles to facilitate handling of the pump (see Using the Optional Carrying Handles).

To optimize working comfort:

- Place the pump 160 mm (6.3 in.) from the front edge of the isolator wall.
- Replace the drain tray support delivered with the pump with the Steritest® Symbio drain tray support, FLEX pump, high integration (see Accessories and Replacement Parts).

The communication hub is not intended to be placed in the isolator. Connect the pump to the communication hub using the Steritest® Symbio connection cable extension with Tri-Clover® clamp (see Accessories and Replacement Parts).

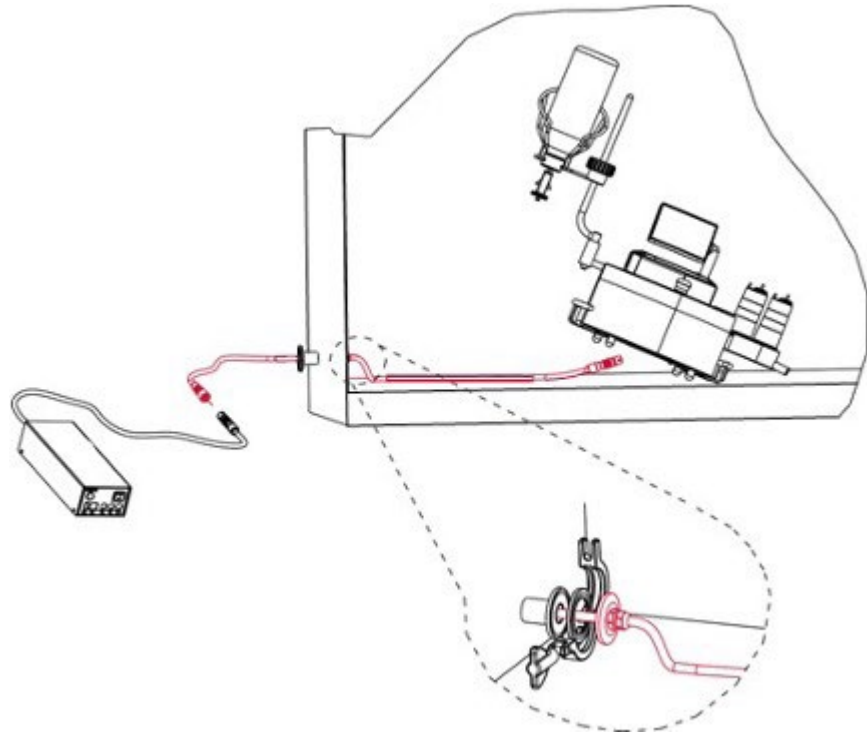

NOTE

To fix the communication hub to one of isolator feet, use the optional communication hub holder for hoods (see Accessories and Replacement Parts.)

8. Connect the communication hub to the power source using the power cord delivered with the pump.
9. Switch on the communication hub by pressing the on/off switch (position I).

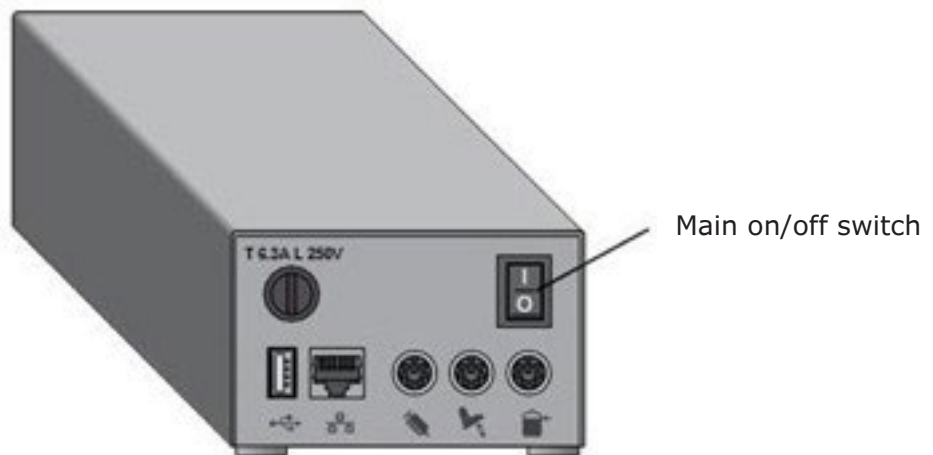

Using the Optional Carrying Handles

The carrying handles are an optional accessory (see Accessories and Replacement Parts). Use them to facilitate pump handling when the pump is installed in a vertical laminar flow environment on feet or in an isolator on feet.

1. Ensure that the pump head is in its closed position.
2. Retrieve the top wedging system from the packaging materials and place it on a flat, stable horizontal surface with the face in which the communication hub was located against the surface.
3. Turn the pump display to its transportation position (horizontal).
4. Turn the pump upside down and place it on the top wedging system.

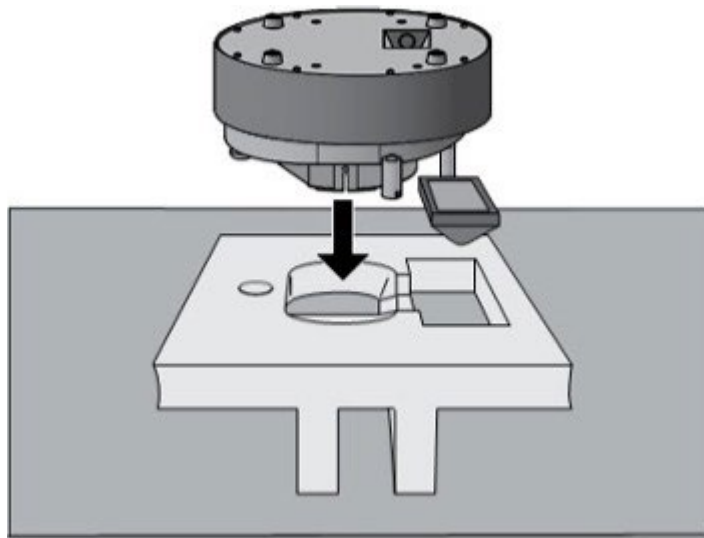

5. Use a #4 hex key to install the optional carrying handles as shown in the following drawing:

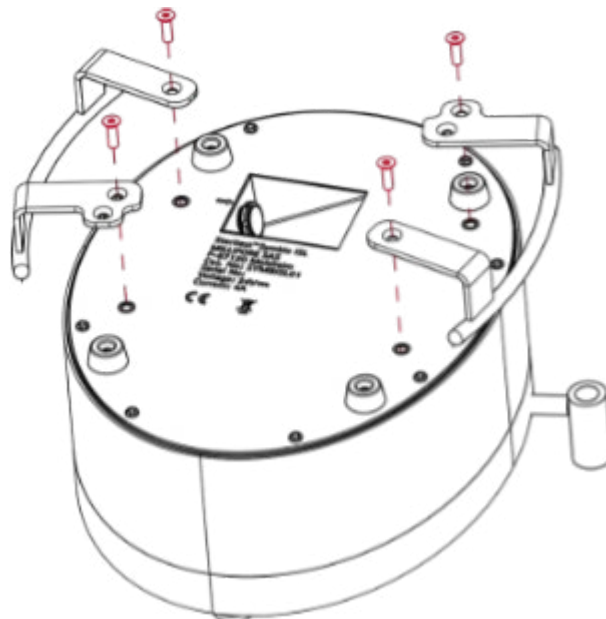

6. Turn the pump right side up and place it in its working environment.

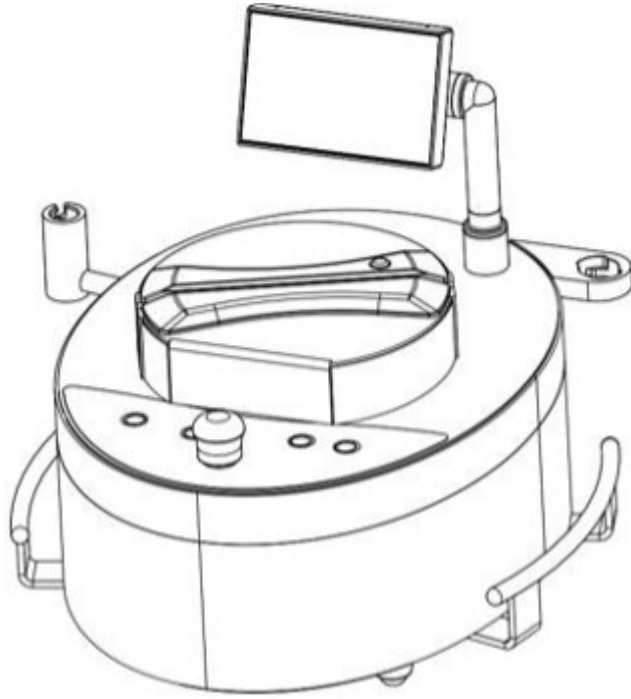

Installing the Pump in a Vertical Laminar Flow Environment: on Feet

1. Verify that the pump functions properly and verify that the pump head is in its closed position (see Tests After Installation).
2. Place the pump and accessories in the vertical laminar flow environment on a flat, stable, and horizontal surface.

NOTE

Use the optional carrying handles to facilitate handling of the pump (see Using the Optional Carrying Handles).

To optimize working comfort:

- Place the pump 160 mm (6.3 in.) from the front edge of the workbench.
 - Replace the drain tray support Using the Optional Carrying Handles with the Steritest® Symbio drain tray support, FLEX pump, high integration (see Accessories and Replacement Parts).
3. Connect the communication hub pump connection cord to the pump power inlet.

NOTE

The communication hub is not intended to be placed in a laminar flow hood or biosafety cabinet. To fix the communication hub to one of the hood/cabinet feet, use the optional communication hub holder for hoods (see Accessories and Replacement Parts.)

4. Connect the communication hub to the power source using the power cord delivered with the pump.
5. Switch on the communication hub by pressing the on/off switch (position I).

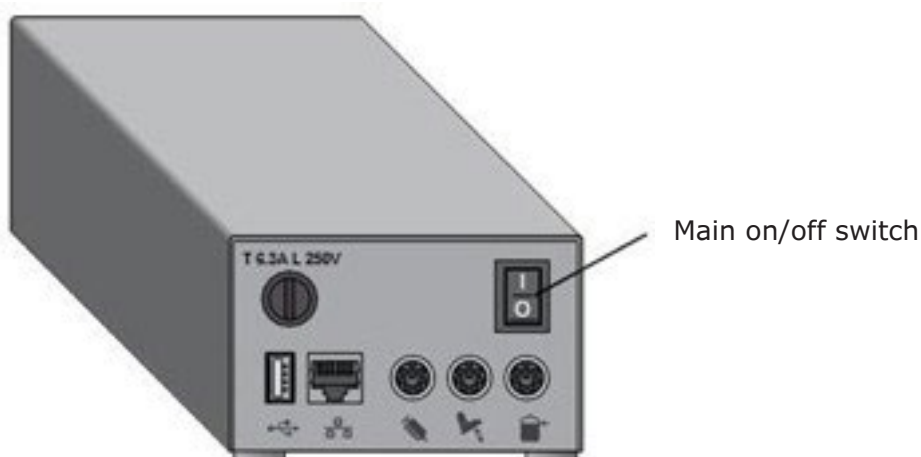

Accessories and Replacement Parts

Description	Quantity per pack	Catalogue Number
Steritest® Symbio Pump		
Steritest® Symbio FLEX Pump Kit, 2 media	1	SYMBFLE01WW**
Steritest® Symbio Pump Services		
Steritest® Symbio pumps validation protocol (A4 format)	1	SYMBA4VP1
Steritest® Symbio pumps validation protocol US (letter format)	1	SYMBLTVP1
NOTE: Contact our sales representative or Technical Service for more information about our application support, validation services, maintenance, and repair services.		
Steritest® Symbio Pump Accessories		
Steritest® Pump footswitch	1	SYMBFSW01
Steritest® glass ampoule breaker	1	SYMBABR01
Steritest® pumps syringe support	1	SYMBSYS01
Steritest® Symbio waste overflow sensor for solid containers	1	SYMBWFS01
Pressure control kit for Steritest® pumps	1	TQ00PSI01
Steritest® holder for sterile bags and Steridilutor vent chamber	1	SYMBSVB01
Steritest® Symbio communication hub holder for isolators	1	SYMBCHI01
Steritest® Symbio pumps universal shipment case	1	SYMBSCA01
Steritest® Symbio pump feet for use in isolator	4	SYMBFEE01
Steritest® Symbio pump feet, height 23 mm (used in laminar flow hood)	4	SYMBFEE02
Steritest® Symbio connection cable extension with Tri-Clover clamp	1	SYMBXTC01
Steritest® Symbio drain tray support for 2 canisters, FLEX pump, high integration	1	SYMBDSF02
Steritest® carrying trays for 5 canisters	8	SYMBCAN08**
Steritest® rack to hold up to 4 canister carrying trays	2	SYMBRACK2**
Steritest® Symbio FLEX optional handles	2	SYMBFHA01
Steritest® Symbio FLEX high integration kit for round cutout	1	SYMBFHR01
Steritest® Symbio FLEX high integration kit for oval cutout	1	SYMBFHV01
Replacement parts		
Steritest® Symbio bottle holder (basket and support rod)	1	SYMBBTH01
Steritest® Symbio bottle holder basket (with fastening screw)	1	SYMBCBH01
Steritest® Symbio accessories support rod	1	SYMBASR01
Steritest® Symbio accessories fastening screw	1	SYMBAFS01
Steritest® Symbio accessories fastening screw clip	1	SYMBFSC01
Steritest® Symbio 2 media drain tray container	1	SYMBDTC01
Steritest® Symbio drain tray support for 2 canisters, FLEX pump, low integration	1	SYMBDSF01
Steritest® Symbio drain tray support for 2 canisters, FLEX pump, high integration	1 1	SYMBDSF02
Steritest® Symbio drain tray support O-rings	5	SYMBDSR02
Steritest® Symbio drain tray support express coupling	1	SYMBSEC01
Steritest® Symbio complete drain tray for 2 canisters, FLEX pump, low integration	1	SYMBDTF01
Steritest® Symbio complete drain tray for 2 canisters, FLEX pump, high integration	1	SYMBDTF02
Drain tubing for Steritest® pumps, silicone, 1.5 meters	1	SYMBTBG01
Steritest® Symbio control knob	1	SYMBKNB01
Steritest® Symbio communication hub	1	SYMBCHB01
Steritest® Symbio communication hub fuses kit, 6.3 A	2	SYMBHF6A
Steritest® Symbio communication hub fuses kit, 3.15 A	2	SYMBHF3A
Pump head cover for Steritest® Symbio 2 media	1	SYMBHEC01

Description	Quantity per pack	Catalogue Number
Power cord for North America, Central America, Mexico	1	FTPF02471
Power cord for Europe	1	FTPF01866
Power cord for United Kingdom, Ireland, Malaysia, Singapore, Hong Kong	1	SIMCABLE1
Power cord for Denmark	1	SIMCABLE2
Power cord for South Africa	1	SIMCABLE3
Power cord for Switzerland	1	SIMCABLE4
Power cord for China	1	SIMCABLE5
Power cord for India	1	SIMCABLE6
Power cord for Japan	1	SIMCABLE7
Power cord for Australia, New Zealand, Argentina	1	SIMCABLE8
Power cord for Italy	1	SIMCABLE9
Power cord for Brazil	1	SIMCABLE11
Steritest® Symbio flat seal for FLEX pump	1	SYMBFSF01
Software (Available at www.millipore.com/steritest-software)		
Steritest® Symbio Software	—	—
Consumables		
Steritest® devices, culture media and rinsing fluids	—	Visit our website or contact our sales representative.
Documentation (Available at www.millipore.com/steritest-symbio)		
Steritest® Symbio Pumps User Guide	1	PF16598
Steritest® Symbio FLEX Pump Installation Guide	1	PF17222
Steritest® Symbio Software User Guide	1	PF16600
Steritest® Symbio Pump Startup Quick Guide	1	PF16601
Steritest® Symbio Pump User Interface Quick Guide	1	PF16602
Steritest® Symbio Software Quick Guide	1	PF16603
Steritest® Symbio pumps low integration installation checklist	1	PF17360
Steritest® Symbio Pumps Isolator Installation Checklist	1	PF17360

* Country code to be defined at ordering step

** Coming soon. Check our website for availability

Symbols Referenced



The presence of this logo on the product testifies the compliance of the Steritest® Symbio Pump with the following European Union directives:

- Electromagnetic compatibility 2014/30/EU
- Low voltage directive 2014/35/EU
- Restriction of the use of certain Hazardous Substances in electrical equipment (RoHS) 2011/65/EU



- In accordance to the European Union Directive 2012/19/EC on Waste Electric and Electronic Equipment (WEEE), the presence of this logo on the product indicates that it should not be disposed of in the normal waste stream but collected separately.

Go to www.sigmaaldrich.com/weee for details on how to ensure proper treatment of the product in different countries.



UK Statutory Instruments and their amendments:



- 2016 No 1101 The Electrical Equipment Safety Regulations 2016
 - 2016 No 1091 The Electromagnetic compatibility Regulations 2016
 - 2017 No.1206 The Radio Equipment Regulations 2017
 - 2012 no 3032 The Restriction of the Use of hazardous Substances in Electrical and Electronic Equipment Regulations 2012
-

Standard Product Warranty

The applicable warranty for the products listed in this publication may be found at: www.millipore.com/ec/cp3/terms (within the “Terms and Conditions of Sale” applicable to your purchase transaction).

Warning:

The pump must be opened to proceed to the installation. This operation does not void the warranty. However, to preserve this warranty, it is mandatory to execute the short test cycles (before and after installation) described in this installation guide.

Use the Steritest® Symbio Pumps Isolator Installation Checklist (PF17360) to document the proper execution of the installation steps and test cycles.

(Download the checklist at www.sigmaaldrich.com)

Deliver this document to the end user of the pump.

Technical Assistance

For more information: www.sigmaaldrich.com/techservice

Technical Assistance

For more information, please visit SigmaAldrich.com
for up-to-date worldwide contact information

