

Protocol Guide

Pellicon[®] Ultrafiltration (UF)/ Diafiltration (DF) Operations



Pellicon[®] Ultrafiltration (UF)/ Diafiltration (DF) Operations Protocol Guide

Introduction.....	3
Objectives, Methods and Materials.....	4
Installation.....	6
Pre-use Flushing Procedure	7
Normalized Water Permeability (NWP) Measurement.....	9
Determination of System Hold-up Volume.....	11
System Equilibration	12
Determination of Optimum TMP	13
Concentration	14
Diafiltration	15
Recovery Operations	17
Clean In Place (CIP)	19
Post CIP Normalized Water Permeability Measurement	20
Storage.....	21
Appendix 1: Diafiltration Buffer Volume Requirements.....	22

Introduction

This guide was created to help scientists and engineers set-up and perform basic operations with Ultrafiltration/ Diafiltration systems. Outlined are the methods and equipment used to perform a TFF sizing study. Consult your local Account Manager for more advanced topics and training.

Objectives, Methods and Materials

Objectives of a UF/DF Study

The objectives of a UF/DF study include determination of cassette capacity (volume/area) and sizing estimations for large volume processing of a given feed stream.

Methods of a UF/DF Study

Feed Stream

The feed stream used in the study should be as representative (as possible) to the actual process (temperature, concentration, density, etc.). Initial and filtrate (post-testing) samples should be taken and tested for product recovery.

Materials

Pellicon® 3 88 cm² Cassettes with Ultracel® Membrane

Description	Catalog Number
3kD NMWL with C-Screen	P3C003C00
5kD NMWL with C-Screen	P3C005C00
10kD NMWL with C-Screen	P3C010C00
30kD NMWL with C-Screen	P3C030C00
30kD NMWL with D-Screen	P3C030D00

Pellicon® 3 88 cm² Cassettes with Biomax® Membrane

Description	Catalog Number
10kD NMWL with A-Screen	P3B 010 A00
30kD NMWL with A-Screen	P3B 030 A00
50kD NMWL with A-Screen	P3B 050 A00

Pellicon® 2 Mini Cassettes with Ultracel® Membrane

Membrane	Catalog Number
5 kD NMWL with C-Screen	P2C0 05C 01
10 kD NMWL with C-Screen	P2C0 10C 01
30 kD NMWL with C-Screen	P2C0 30C 01
100 kD NMWL with C-Screen	P2C1 00C 01
5 kD NMWL with C-Screen	P2C0 05V 01
10 kD NMWL with C-Screen	P2C0 10V 01
30 kD NMWL with C-Screen	P2C0 30V 01
100 kD NMWL with C-Screen	P2C1 00V 01

Objectives, Methods and Materials

Accessories

Description	Quantity	Catalog Number
LabScale® Tank (Retentate Tank)	1	XX42LSS11
Pellicon® Mini Holder	1	XX42PMINI
Pellicon® Mini spacers	1 package of 4	XX42PMPSP
3/4 in. sanitary gaskets (silicone)	1 bag	FTPF03342
Torque wrench	1	XX42PMITW
9/16 in. deep socket	1	XX42PMISR
3/4 in. TC clamps plastic	4	XX42T1900
Feed Pressure Gauge (0-60psi)	1	XX42LSP20
Retentate Pressure Gauge (0-60psi)	1	XX42LSP20
Plastic Gauge Tee	2	XX42LSP29

Additional Ordering Information

Description	Quantity	Vendor	Catalog Number
Nalgene® Square PETG Media Bottles with Closure: Non-sterile, Shrink Wrapped Trays	1	Thermo Scientific	322020-500
Thermo Scientific Nalgene® Top Works 38-430 Cap 1/4 in. ID	1	Cole-Parmer	GH-13070-02
Masterflex® Pharmed BPT Tubing (size 16)	1 pack of 25 feet	Cole-Parmer	GH-06508-16
Masterflex® Silicone Tubing (size 16)	1 pack of 25 feet	Cole-Parmer	GH-96400-16
3/4 in. Tubing Adapter	4	Cole-Parmer	31200-50
Manual Pinch Valve (5/32 to 1/4 in. tube OD)	1	Cole-Parmer	EW-98002-00
Luer Stopcocks	10	Cole-Parmer	31200-91
StableTemp® Ceramic Stirrer	1	Cole-Parmer	GH-03406-00
Masterflex® Pump (0-600 rpm)	1	Cole-Parmer	EW-07522-20
Masterflex® Pump Head	1	Cole-Parmer	GH-77200-60
Stopwatch	1	Cole-Parmer	GH-35002-15
Mettler Toledo® NewClassic ML Toploading Balance	1	Cole-Parmer	GH-11334-87
Luer Fittings	1 bag	Value Plastic	MTLL230
Luer Fittings	1 bag	Value Plastic	FTLL230
Luer Stopcocks	10	Cole-Parmer	31200-91
60mL Syringe with Luer-Lok™ Fitting	1	Fisher Scientific	22-031-375

Installation

- 1.1 Set up system per general arrangement drawing. In principle, the tubing lengths should be minimized so as to minimize the working volume of the system. This enhances the ability to reach higher concentrations and lowers non-recoverable volumes (recovery loss).

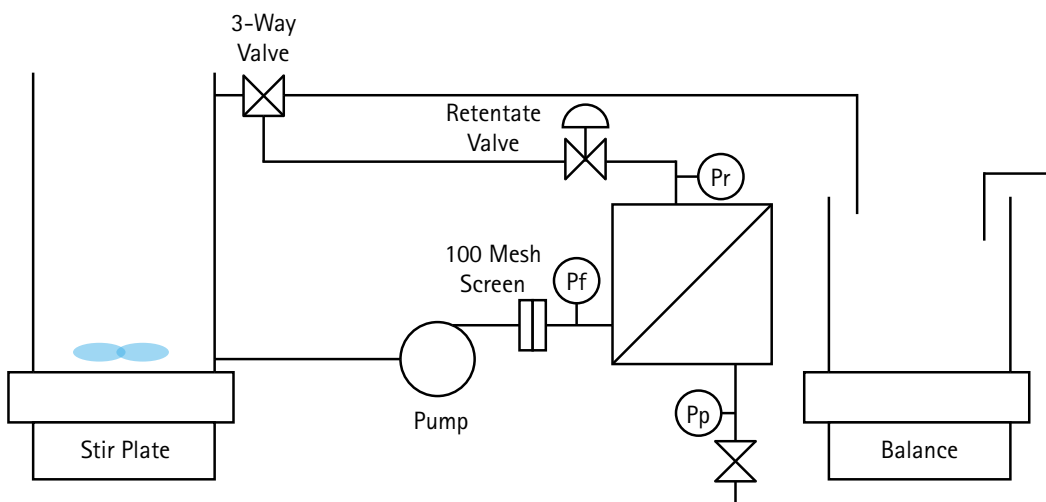

Figure 1.
UF/DF System
General Arrangement

- 1.2 The permeate (or filtrate) pressure gauge may be omitted in standard UF operation since there should not be any filtrate pressure in this line.
- 1.3 Install the membrane as per the installation guide included in the membrane device box. Silicone gaskets are included in the Pellicon® 2 Device Box and must be used with the Pellicon® 2 membranes to achieve a proper device to holder seal. Pellicon® 3 devices (mini and micro) have gaskets that are integral to the device that make the device to holder seal.
 - 1.3.1 When working with micro (0.88cm²) devices the required torque might be lower than the specification. If during the flushing procedure a high feed pressure (≥ 14 psig) is observed loosen the membrane from the holder and re-torque to 140 in-pounds.

Pre-use Flushing Procedure

2.1 Pellicon® devices come from the factory pre-wet with preservative solution that must be removed before processing product. See Table 1 for flush volume recommendations.

Recommendations Step	Flow path	Solution	Minimum Volume Required (L/m ²)	Time (min)
Flushing preservative	Single Pass	RO water	20	30
CIP / Sanitization	Single Pass	Ultracel® 3kDa, 5kDa membrane 0.1N NaOH <hr/> Ultracel® 10kDa, 30kDa membrane 0.2N NaOH <hr/> Biomax® 10kDa, 30kDa membrane 0.5N NaOH	10	
CIP / Sanitization	Total Recycle	Ultracel® 3kDa, 5kDa membrane 0.1N NaOH <hr/> Ultracel® 10kDa, 30kDa membrane 0.2N NaOH <hr/> Biomax® 10kDa, 30kDa membrane 0.5N NaOH	5	30
Flushing sanitization solution	Single Pass	RO water	10	30
Flushing and NWP test	Total Recycle	RO water	5	
Equilibration	Single pass	Equilibration buffer	15	10 -15
Equilibration	Total Recycle	Equilibration buffer	10	

Table 1. Sanitization Solution and Flushing Volume

2.2 Arrange the system flowpath into the Single-Pass Filtrate Open mode (SPFO) as shown in Figure 2.

2.3 Fill the feed vessel with the required purified water volume from Table 1.

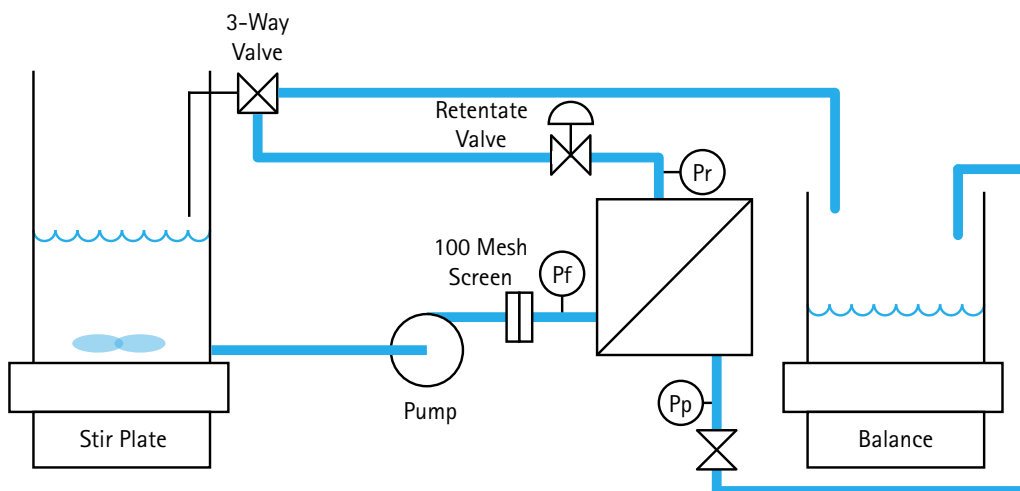

Figure 2. Single-Pass Filtrate Open mode (SPFO) Arrangement

Methods

- 2.4 Set the retentate Valve to fully open. Set the pump to supply 5 LMM (L/min/m²) feed flow rate.
- 2.5 Start the pump and monitor the feed pressure gauge. The pressure should stabilize to between 5-14 psig. If the pressure is outside this guideline, re-check the installation and torque wrench settings.
- 2.6 Set the retentate pressure to 5 psig so as to ensure that the membrane is being fully flushed. Continue until the volume in the feed vessel is minimized, then stop the pump. Do not entrain air into the system.
- 2.7 See Table 1 and add required volume of sanitization solution, to the feed vessel. Set the system in 'Single Pass' flow path. Start the pump to displace the water from the lines and the internal volume of the membrane to avoid dilution. When the sanitization solution level in the feed vessel had been minimized, stop the pump before air is entrained into the system.
- 2.8 Set the system flowpath to the total recycle mode (Figure 3). Fill the vessel with required volume of sanitization solution, see Table 1.

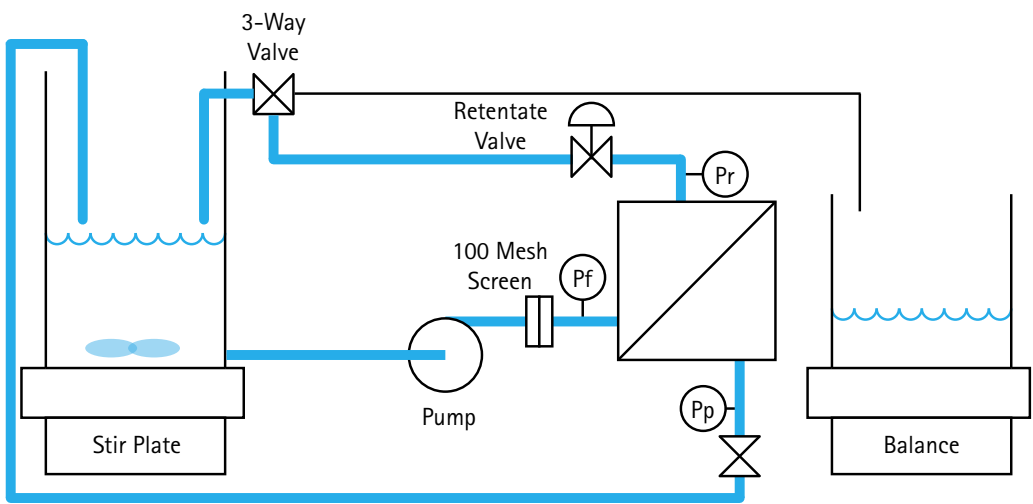

Figure 3.
Total Recycle Mode

- 2.9 Recirculate at 5 LMM feed flowrate for 30-60 min. Set the retentate pressure to ~5 psig to ensure CIP (Clean-In-Place) of the full membrane area.
- 2.10 Stop the pump after the CIP time interval. Return the system flowpath to the SPFO mode (Figure 2). Start the pump again and pump the feed vessel out to the receiver vessel. When CIP solution level in the feed vessel had been minimized, stop the pump before air is entrained into the system.
- 2.11 Fill the feed vessel with purified water and start the pump. Flush the system to drain back to neutral pH. A microcassette based system will require approximately 1 L of purified water. Monitor pH with a meter or pH paper that sensitive in the neutral range. Check both retentate and permeate lines separately to ensure the system is truly back to neutral pH. Stop the pump.

Normalized Water Permeability (NWP) Measurement

- 3.1 Add additional purified water to the feed vessel if necessary to ensure that the NWP measurement can be made without entraining air into the system.
- 3.2 Set the system flowpath to the total recycle mode. Start the pump and manipulating the feedflow, set the system feed pressure to read 10 psig and the retentate pressure to read 5 psig.
- 3.3 Allow the system to recirculate for a minute or two. Measure the temperature of the feed vessel contents. Set the system flowpath to the UF concentration mode (Figure 4) and measure the change in mass over an elapsed time of 1 min, to find the permeate flowrate.

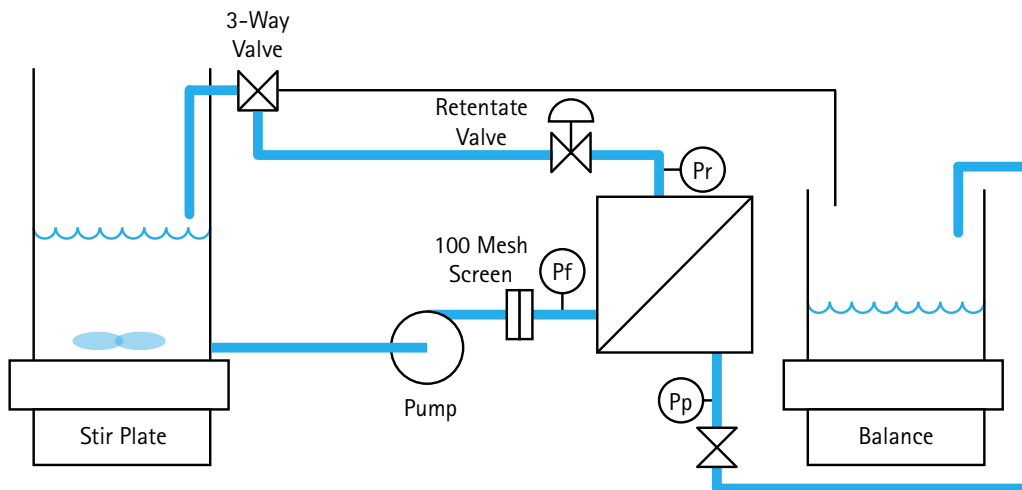

Figure 4.
Concentration Mode

- 3.4 Calculate the Normalized Water Permeability of the membrane using the following formulas:

Equation 1 $J = Q_p/A$

Where:

J = Volumetric Flux (L/M²/Hr)

Q_p = permeate flow rate in L/hr

A = Area of the membrane device(s)

and

Equation 2 $NWP = J * F / \text{Transmembrane pressure (TMP)}$

Where:

NWP = Normalized Water Permeability (L/M²/Hr/psid)

J = Volumetric Flux (L/M²/Hr)

F = Temperature Correction Factor

TMP = Transmembrane pressure $(P_{\text{feed}} + P_{\text{ret}})/2 - P_{\text{perm}}$ (pressure drop across the membrane in psid)

Normalized Water Permeability (NWP) Measurement

Temperature		F	Temperature		F	Temperature		F
(°F)	(°C)		(°F)	(°C)		(°F)	(°C)	
125.6	52	0.595	96.8	36	0.793	68.0	20	1.125
123.8	51	0.605	95.0	35	0.808	66.2	19	1.152
122.0	50	0.615	93.2	34	0.825	64.4	18	1.181
120.2	49	0.625	91.4	33	0.842	62.6	17	1.212
118.4	48	0.636	89.6	32	0.859	60.8	16	1.243
116.6	47	0.647	87.8	31	0.877	59.0	15	1.276
114.8	46	0.658	86.0	30	0.896	57.2	14	1.310
113.0	45	0.670	84.2	29	0.915	55.4	13	1.346
111.2	44	0.682	82.4	28	0.935	53.6	12	1.383
109.4	43	0.694	80.6	27	0.956	51.8	11	1.422
107.6	42	0.707	78.8	26	0.978	50.0	10	1.463
105.8	41	0.720	77.0	25	1.000	48.2	9	1.506
104.0	40	0.720	75.2	24	1.023	46.4	8	1.551
102.2	39	0.748	73.4	23	1.047	44.6	7	1.598
100.4	38	0.762	71.6	22	1.072	42.8	6	1.648
98.6	37	0.777	69.8	21	1.098	41.0	5	1.699

Table 2.
Normalized Water
Permeability Temperature
Correction Factor (F)*

*Based on Water Fluidity Relative to 25°C (77°F) Fluidity Value $F = (\mu_{T_c} / \mu_{25^\circ C})$ or $(\mu_{T_f} / \mu_{77^\circ F})$

3.5 This is now the baseline permeability of the device. Record this value in the experimental notebook or runsheet.

Determination of System Hold-up Volume

- 4.1 Set the retentate valve to fully open. Adjust the feedflow to 5 LMM and reduce the volume in the feed vessel to just above the vessel discharge. Stop the system pump.
- 4.2 Obtain a suitable container to capture the remaining volume in the system (50 mL tube for a microcassette based system). Record the tare weight of the container. Set the system feed rate to 2-3 LMM.
- 4.3 Set the system flowpath to the recovery mode (Figure 5). Close the permeate isolation valve. Start the pump and collect all of the remaining liquid in the system into the sample container.

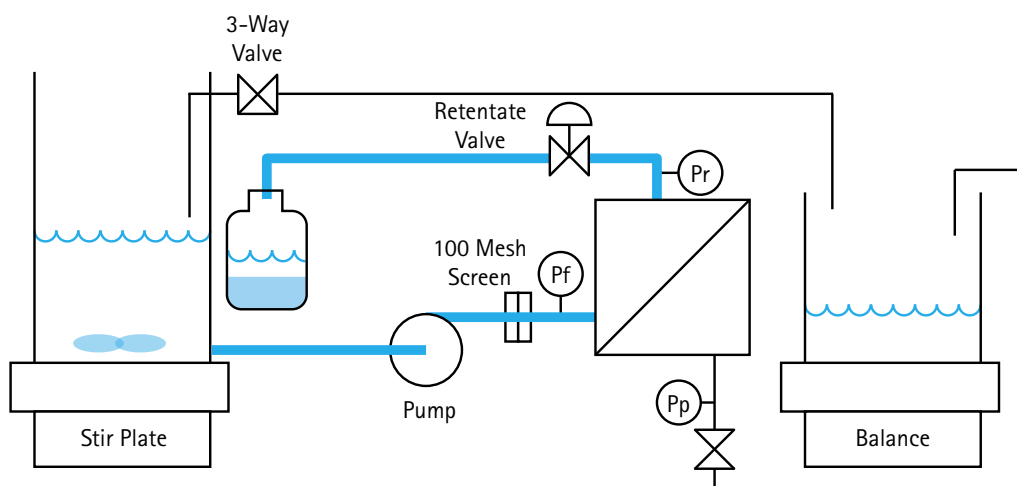

Figure 5.
Recovery Mode

- 4.4 Weigh the gross weight of the container and record the net weight of container and convert this to volume. Add 5 mL to the amount to calculate the total hold-up volume in the system for a micro-cassette based system. Add 31 mL to the amount to calculate the total hold up volume for a mini-cassette based system.

System Equilibration

- 5.1 Arrange the system flowpath into the Single-Pass, Filtrate Open mode (Figure 2). Open the permeate isolation valve.
- 5.2 Fill the feed vessel with the equilibration buffer volume (see recommended volumes in Table 1).
- 5.3 Set the pump to supply 5 LMM feed flow rate. Set the retentate pressure to 5 psig by restricting retentate flow with the retentate valve. Collect ~ 3 working volumes into the receiver.
- 5.4 Fully open retentate valve, then stop the pump and place the system into the total recycle mode. Start the pump, set retentate pressure to 5psi, and operate in total recycle for ~5 min.
- 5.5 Stop the pump and reset the system in to the SPFO mode. Set the Transmembrane pressure of the system to ~15 psid (e.g., $P_{\text{feed}}=20$ psig, $P_{\text{ret}}=10$ psig). Start the pump and reduce the volume in the feed vessel to just above the vessel discharge. Do not withdraw too much liquid from the feed vessel and entrain air into the system. Stop the pump. Open the retentate valve to full open. The system now has just the hold-up volume of buffer in it and is ready to accept the protein feed.
- 5.6 Add the feed to the feed vessel. The total system volume = amount of feed added + the hold-up volume. The total system volume is considered V_0 and is used to calculate concentration factor, diafiltration number, etc.

Determination of Optimum TMP

- 6.1 Set the system flowpath to the total recycle mode (Figure 3).
- 6.2 Start the agitator. The agitator should spin fast enough to cause a slight depression in the surface of the liquid in the vessel. The agitator should be monitored during the process and never be allowed to vortex the liquid and entrain air or cause foaming.
- 6.3 Set the feedflow to 5 LMM. Allow the system to operate in the total recycle mode for ~5 minutes with the retentate valve fully open. Record temperature, Feed pressure, Retentate pressure and elapsed time.
- 6.4 Measure the permeate flowrate by redirecting the permeate line to a receiver on a balance or by collecting in a graduate cylinder. Measure the volume (mass) for 1 min. Record the volume and calculate flux.
- 6.5 Manipulating the retentate valve, increase the Transmembrane pressure by 5 psid. The TMP should increase but the DP ($P_{\text{feed}} - P_{\text{ret}}$) should remain constant (see the example in Table 3).

P_{feed}	P_{ret}	P_{perm}	TMP	P	Flux
15	0	0	7.5	15	10
20	5	0	12.5	15	18
25	10	0	17.5	15	23
30	15	0	22.5	15	26
35	20	0	27.5	15	27
40	25	0	32.5	15	27.5
45	30	0	37.5	15	27.5

Table 3.
Flux Excursion Data

- 6.6 Repeat this measurement until the membrane flux becomes insensitive with the change in TMP. Reduce the TMP to and re-measure 1-2 of the flux measurements. If they are different by greater than 10% the membrane may have become polarized or fouled. Generally, avoid operating too far into the flux insensitive region.
 - 6.6.1 If polarization has occurred a depolarization step is recommended. To achieve this, lower the flow rate to ~10% of the operating feed flow rate and let the system run in total recycle for a minimum of 5 minutes. After the time has elapse re-measure the flux and compare to the original value. If the re-measured flux continues to differ by more than 20% the membrane may be fouled. At this point it is likely that the flux can only be restored by stopping the experiment and cleaning. (See section 9 for more on depolarization)
- 6.7 The optimum TMP is found by selecting a pressure slightly below the "knee" of the flux vs. TMP curve. In the example the knee of the curve is 23-24 psid (Figure 7). The optimum TMP at this concentration is 20 psid.

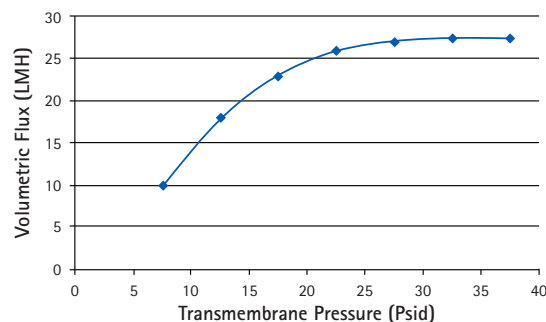

Figure 6.
Flux and TMP Excursion
Example at 5 LMM

- 6.8 The Optimum TMP experiment may be repeated at an intermediate concentration and at the final concentration or just the final concentration to find an over-all process TMP optimum.

Concentration

- 7.1 Determine the required permeate volume needed to be collected to achieve the target concentration.

Equation 3 $V_p = V_{si} - (V_{si} \times \text{Conc}_i / \text{Conc}_t)$

Where:

V_{si} = Initial System Volume (Feed Volume + Hold-up Volume)

Conc_i = Initial Concentration

Conc_t = Target Concentration

V_p = Target Permeate Volume

- 7.2 Zero the balance and set the system flowpath to concentration mode and start the pump and the timer.
- 7.3 Set the TMP to the previously determined optimum TMP. Record time, temperature, the pressures and the permeate weight.
- 7.4 As the concentration step progresses, the feed pressure (and TMP) may rise due to viscosity increase as a function of concentration. Adjust the retentate valve to hold TMP constant. The retentate valve may be fully open before the concentration step is finished. Adjust the pump to hold TMP constant. At higher concentrations the viscosity may become so high, it is not possible to control TMP with the pump. This is a concentration end point for the fluid & membrane pair. If a higher concentration is still desired, it may be necessary to select a more open screen type.
- 7.5 Once the concentration target is reached, open the retentate valve to full open. Stop the pump and close off the permeate isolation valve.

Diafiltration

8.1 Arrange the system flowpath to the Vacuum Diafiltration mode (Figure 8).

8.1.1 If creating a vacuum is not possible with the equipment being used a second pump can be used to draw the DF buffer into the retentate vessel. The flowrate on the DF buffer pump must be set to match the flowrate of the permeate line. Adjustments to the flowrate of the DF buffer pump might be necessary throughout the process. This will ensure that the concentration within the system remains constant throughout the diafiltration step.

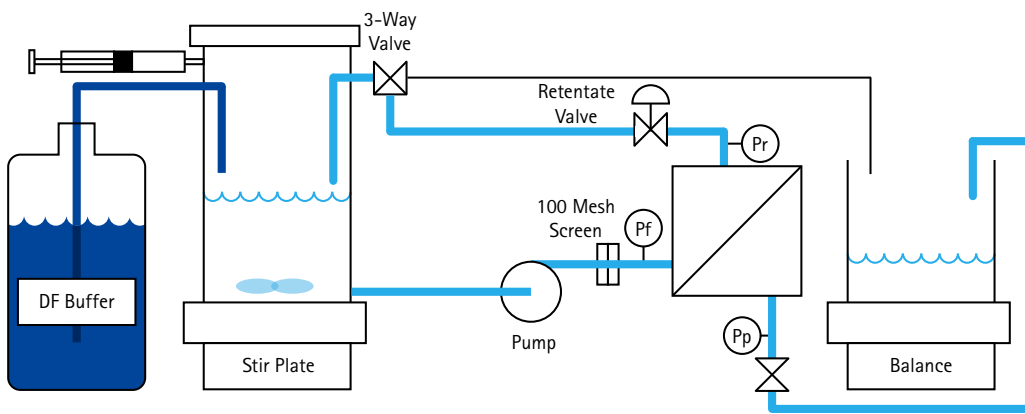

Figure 7.
Vacuum Diafiltration Mode

8.2 The amount of diavolumes used for purification of a target impurity is usually selected as the minimum amount of diavolumes required to achieve the purity target, plus a 2 diavolume safety factor. For example, if 6 diavolumes are required to achieve the purity target, then 8 diavolumes are used in the DF step. 1 diavolume is equivalent to the amount of fluid in the system ($V_f + V_h - V_p$). The number of diavolumes, N required for purification can be calculated by the following equation. Alternatively the figure in Appendix 1 can be used.

Equation 4 $C_f = C_i e^{-S \cdot N}$

Where:

- C_f = Final concentration of solute being diafiltered out
- C_i = Initial concentration of solute being diafiltered out
- S = sieving/passage coefficient = $C_{\text{permeate}}/C_{\text{retentate}}$
- N = Number of diavolumes

The target permeate volume required to achieve the number of calculated diavolumes can be determined using equation 5.

Equation 5 $N \cdot V_s = V_p$

Where:

- N = Number of diavolumes
- V_s = Volume in the system post concentration
- V_p = Target permeate volume

Diafiltration

- 8.3 Mark the level in the vessel with a marker or piece of lab tape to be sure that the volume remains constant during diafiltration. Obtain a container with the required amount of DF buffer. Attach the DF line to the feed vessel. Cap off the vessel and pull a vacuum on the vessel headspace with a syringe to prime the diafiltration line.
- 8.4 Start the pump. Adjust the TMP to match the TMP at the end of the concentration step. Record temperature, Feed pressure, Retentate pressure temperature, elapsed time and permeate weight (volume).
- 8.5 When the diafiltration target volume has been reached, open the retentate valve, stop the pump, stop the agitator and close the permeate isolation valve.

Recovery Operations

- 9.1 The first step in the recovery operation is depolarization of the membrane. Polarization is a concentration gradient that occurs due to convective transport of protein towards the membrane wall. The depolarization step is recirculation under low feedflow and TMP conditions with the permeate isolation valve shut. Running with the permeate isolation valve closed can give rise to reverse pressure within the device. Limit the ΔP to ≤ 20 psid for Pellicon® 3 devices and ≤ 10 psid for Pellicon® 2 devices.
- 9.2 Arrange the system flowpath to the Depolarization mode (Figure 8) by closing the permeate isolation valve, setting the retentate valve fully open and starting the pump. Operate the pump at low feedflow rates – low enough to avoid the ΔP limits outline in step 9.1.

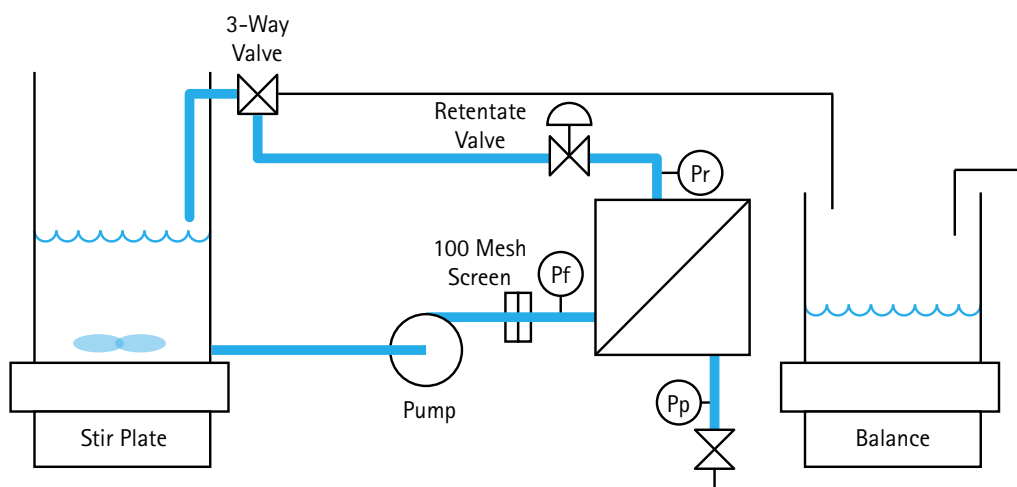

Figure 8.
Depolarization Mode

- 9.3 Recirculate the system in the depolarization mode for 5-10 min. Stop the pump after the recirculation time limit.
- 9.4 Set the system flowpath to the blowdown/recovery mode as shown in Figure 9. Pump the protein product out at low ΔP into an appropriate sized container. When air bubbles appear stop the pump. Do not allow the protein product to foam.
- 9.5 Add to the feed vessel 1 minimum working volume of buffer. Start the pump and recover this pool separately in container. As before, when air bubbles appear stop the pump. Do not allow the protein product to foam. Add this buffer chase pool to the recovery pool to increase recovery if the pool can tolerate dilution.
- 9.6 Set the system into the total recycle mode (Figure 3). Add to the feed vessel 1-2 diavolumes of buffer to the system. Set the retentate valve to fully open. Set the feed flowrate to 2-3 LMM and recirculate for 5-10 min.
- 9.7 Set the system flowpath to the blowdown/recovery mode as shown in Figure 9 (next page). Pump the recirculated buffer out at low ΔP into an appropriate sized container. When air bubbles appear stop the pump.

Recovery Operations

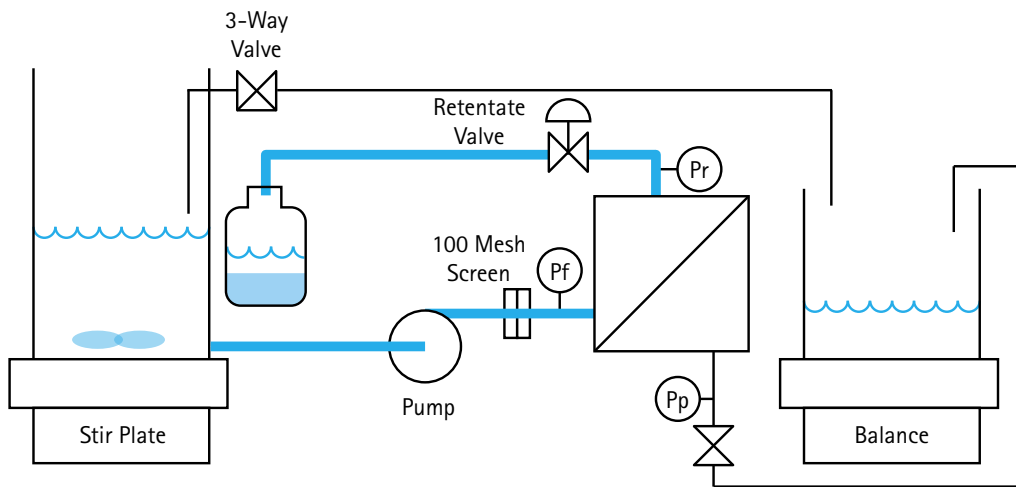

Figure 9.
Recovery Mode

Clean In Place (CIP)

- 10.1 Add 200-300 mL of recommended CIP / Sanitization (Table 1) solution to the feed vessel. Set the system flowpath to the total recycle mode (Figure 3).
- 10.2 Recirculate at 5 LMM feed flowrate for 30-60 min. Set TMP to approximately 15psid.
- 10.3 Stop the pump after the CIP time interval. Return the system flowpath to the SPFO mode (Figure 2). Start the pump again and pump the feed vessel out to the receiver vessel.
- 10.4 Add purified water to the feed vessel and start the pump. Flush the system to drain back to neutral pH. A microcassette based system will require approximately 1 L of purified water. Monitor pH with a meter or pH paper that sensitive in the neutral range. Check both retentate and permeate lines separately to ensure the system is truly back to neutral pH. Stop the pump.

Post CIP Normalized Water Permeability Measurement

- 11.1 Add additional purified water to the feed vessel if necessary to ensure that the NWP measurement can be made without entraining air into the system.
- 11.2 Set the system flowpath to the total recycle mode. Start the pump and manipulating the feedflow, set the system feed pressure to read 10 psig and the retentate pressure to read 5 psig.
- 11.3 Allow the system to recirculate for a minute or two. Measure the temperature of the feed vessel contents. Set the system flowpath to the UF concentration mode (Figure 4) and measure the change in mass over an elapsed time of 1 min, to find the permeate flowrate.
- 11.4 Calculate the post CIP Normalized Water Permeability as we did in Section 3 using equations 1 and 2.
- 11.5 Compare the Base-line NWP to the post CIP NWP. The Post CIP NWP should be $\geq 80\%$ of the Base-line NWP. $(\text{Post CIP NWP} / \text{Base-line NWP} * 100\%)$. If the comparison is less than 80%, then the membrane can be re-cleaned. CIP at an elevated temperature may be more effective at restoring NWP. NWP is a single indicator of membrane cleaning success. Data such as batch to batch process time, product quality and carryover studies should be used to determine criteria for successful membrane CIP processes.

Storage

- 12.1 Arrange the system flowpath into the Single-Pass, Filtrate Open mode (Figure 2). Open the permeate isolation valve.
- 12.2 Fill the feed vessel with 4 diavolumes of 0.1N NaOH solution.
- 12.3 Set the pump to supply 5 LMM feed flow rate. Set the retentate pressure to 5 psig by restricting retentate flow with the retentate valve. Collect ~ 2 diavolumes into the receiver.
- 12.4 Fully open retentate valve, then stop the pump and place the system into the total recycle mode (Figure 3).
- 12.5 Start the pump, recirculate the remaining 2 diavolumes at 5LMM for 5-10 min. Set TMP to approximately 15 psid.
- 12.6 Remove membrane and store in 0.1N NaOH in a 2-8° C refrigerator.

Appendix 1: Diafiltration Buffer Volume Requirements

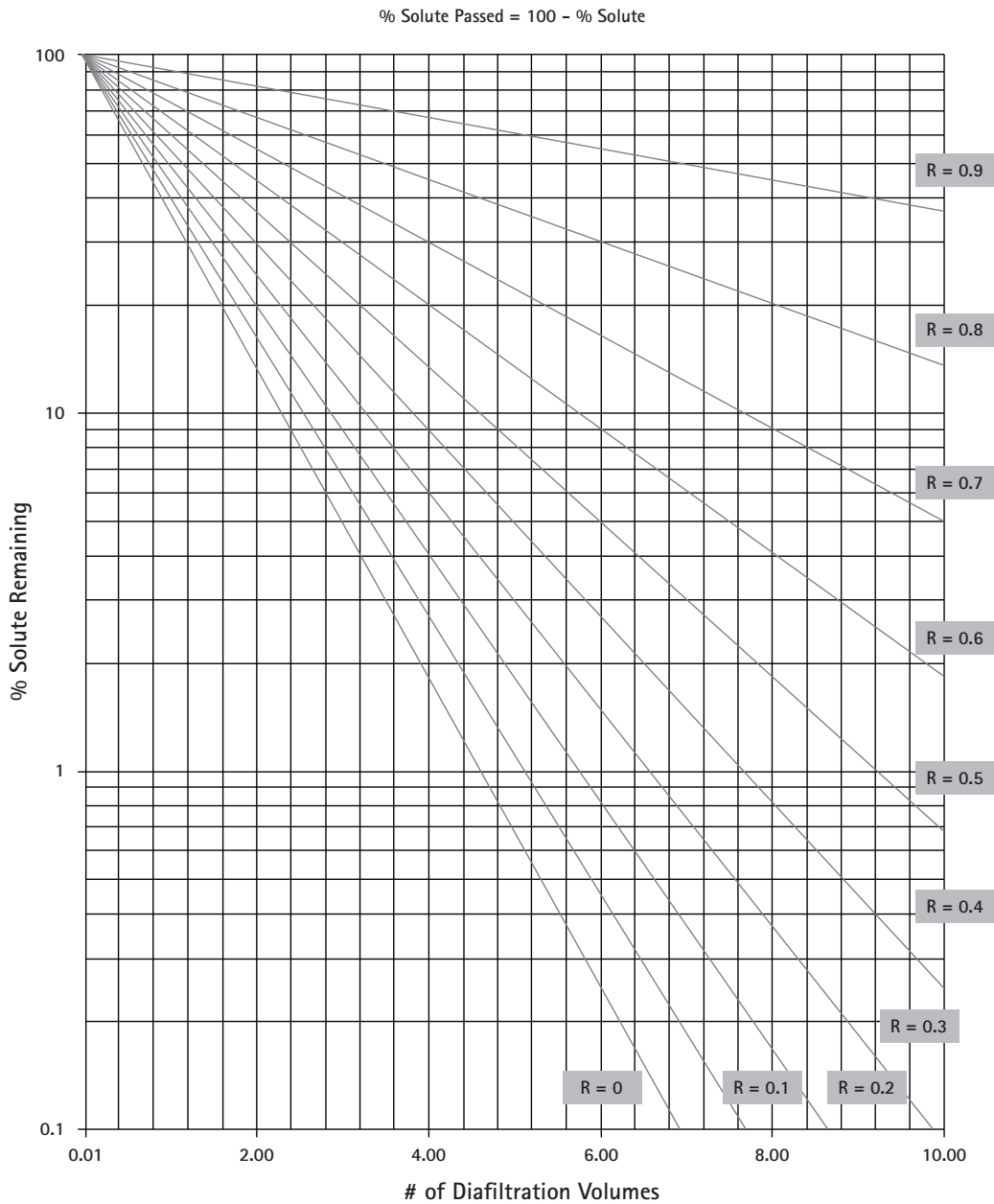

Figure 10.
Solute remaining
versus number of
diafiltration volumes



www.emdmillipore.com

EMD Millipore, the M logo, Ultracel, Biomax, Labscale and Pellicon are registered trademarks of Merck KGaA, Darmstadt, Germany.

Masterflex and StableTemp are registered trademarks of Cole-Palmer Instrument Company.

Luer-Lok is a trademark of Becton Dickinson.

MICROMETER is a registered trademark of RMFPT, Inc.

Nalgene is a registered trademark of Nalge Nunc International Corporation.

Lit No. RF1159EN00 Ver. 3.0 4/2016

© 2016 EMD Millipore Corporation, Billerica, MA USA. All rights reserved.

To Place an Order or Receive Technical Assistance

In the U.S. and Canada, call toll-free 1-800-645-5476

For other countries across Europe and the world,
please visit: www.emdmillipore.com/offices

For Technical Service, please visit:
www.emdmillipore.com/techservice