

EZ-Pak™

Membrane Dispenser – Distributeur de membranes
Membran-Dispenser – Dispensador de membranas
Dispensatore di membrane – Membrane Dispenser
メンブレンディスペンサー



Operation and Maintenance Instructions – Manuel d'utilisation et d'entretien
Betriebs- und Wartungsanleitung – Instrucciones de utilización y mantenimiento
Manuale operativo e di manutenzione

取扱説明書

MILLIPORE

ENGLISH



EZ-Pak

Membrane Dispenser

Operation and Maintenance Instructions

CONTENTS

	Page
1 - Introduction	4
2 - Component Parts	5
3 - Start-up	6 to 8
4 - Using the Membrane Dispenser	9
5 - Maintenance	10
6 - Specifications	10
7 - Troubleshooting	11 to 13
8 - Replacing Wear Parts	14 to 16
9 - Ordering Information	17
10 - Warranty	18

Millipore Offices Worldwide

1 INTRODUCTION

Congratulations for your choice of **EZ-Pak™** membranes and dispenser for microbiological analysis of liquid samples.

The **EZ-Pak** system consists of sterile membranes packed in a special pleated band within a cartridge and specially designed equipment to allow individual membrane dispensing.

EZ-Pak is designed to be used under standard «clean conditions» and with traditional membrane filtration methods.

With **EZ-Pak**, three delicate manipulations are eliminated: opening individual sterile envelopes, separating the membrane from its protective papers and removing the fragile membranes from their packaging.

The **EZ-Pak** cartridges contain 150 black or white gridded 47-mm or 50-mm diameter membranes, and should be used with the Microfil™ filtration system for maximum ease of use, speed and cleanliness. Of course, **EZ-Pak** is also an ideal complement to traditional filtration equipment.



2 COMPONENT PARTS

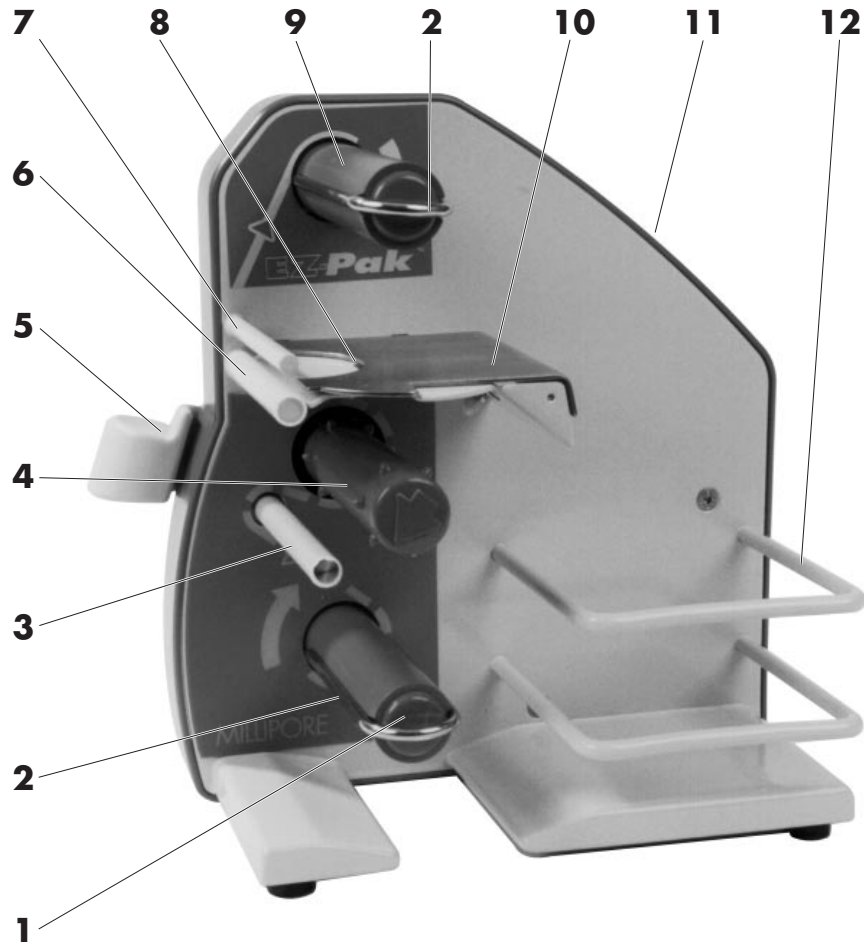

FIGURE 1 - Assembly and component parts

- | | |
|----------------------------|---------------------------------------------------------|
| 1 - Paper spool | 8 - Tensioning spring
(located under the back cover) |
| 2 - Film/paper spool clips | 9 - Film spool |
| 3 - Paper guide | 10 - Metal cover |
| 4 - Drive roller | 11 - Carrying handle
(moulded in the external case) |
| 5 - Actuator | 12 - Membrane cartridge holder |
| 6 - Plate | |
| 7 - Separating bar | |

3 START-UP

.....

1. Remove the dispenser from its packaging and place it on the work surface with the dispensing mechanism facing you.
2. Check that all the component parts are undamaged and in place as shown in Figure 1.

3. Open an **EZ-Pak** membranes cartridge by detaching the pre-cut top cover and folding it over backwards (see Fig. 2).



Fig. 2

4. Insert the cartridge in the holder so that the label is visible (see Fig. 3).



Fig. 3

5. **Important operation:** Fully depress the *actuator* before proceeding to ensure correct indexing of the *drive roller*. The arrow on the *drive roller* must point vertically upwards.

Caution: Avoid letting the actuator spring back into place. Slow the movement with the finger.

6. Remove the *metal cover* by separating the cover tab from the *plate tab* (see Fig. 4).



Fig. 4

.....

-
7. Pull out the band until the first cell containing a membrane is visible (see Fig. 5).

Note: *The first cells on the band do not contain membranes. This avoids wasting membranes when installing the band.*

8. Introduce the **EZ-Pak** band under the *separating bar*. Pull gently on the band to pass 3 empty cells under the *separating bar*.



Fig. 5

9. Reinstall the *metal cover* by inserting the pins in the housings, then aligning the *cover tab* with the *plate tab* (see Fig. 6). The locking ball should audibly «snap» into place.



Fig. 6

10. Peel away the transparent plastic film from the paper backing of the first cells up to the *separating bar*.

11. Pull the backing paper through the mechanism as shown in Figure 1.

Important operation:

Make sure the red arrow on the paper after the second fold is located above the vertical arrow on the *drive roller*. Engage the backing paper on the sprockets.



Fig. 7

.....

12. Rotate the *paper spool* until the *clip* is horizontal. Remove the *paper spool clip*. Place the backing paper on the spool and secure it with the *clip*. If necessary, manually rotate the *paper spool* clockwise to take up any slack.

13. If necessary, slightly pull the backing paper back from the *cover* toward the *holder* until there is no slack left in the paper between the *separating bar* and the *drive roller*.



Fig. 8

14. Remove the *film spool clip*, place the end of the *film* on the *film spool* and secure it with the *clip*, being careful not to twist the film. The film should be firmly held between the *clip* and spool.

Manually rotate the *film spool* clockwise to take up the slack (see Fig. 7).

15. Fully depress the *actuator* once then release it, slowing the upward movement with the finger.

16. Verify that the membrane band is correctly installed by checking that the cell dispensed is approximately one-third open (the bluish seal should be peeled off around one-third of the edge) and that there is no slack in either the film or the backing paper.

The **EZ-Pak** membrane dispenser is now ready for use.

.....

4 USING THE MEMBRANE DISPENSER

1. Position the dispenser on the left-hand side* of your workstation with the Millipore logo directly facing you as shown in Figure 9.
2. To aseptically dispense a membrane, fully depress the *actuator* with your left* hand. Repeat this step if the cell released does not contain a membrane. The number 001 indicating the first membrane can be seen on the film above the *separating bar*. During these operations, avoid letting the actuator spring back into place. Slow the movement with the finger.
3. The membrane will be dispensed horizontally and held in place in the semi-opened cell (see Fig. 9). Use a flamed and cooled forceps (see Fig. 9) to remove the membrane with the right hand* by pulling it straight out from the cell and setting it on a Microfil or conventional Millipore filtration support.
4. Proceed with filtration in the normal manner.
5. After dispensing the last membrane, pull off the *clips* and remove the rolls of used packaging.

* invert if the operator is left handed



Fig. 9

5 MAINTENANCE

The case surfaces may be cleaned using a mild detergent or decontaminated with alcohol. No other maintenance is required.

If the outside case was exposed to UV rays often for relatively long periods, it may have become slightly dull. Wiping it off with a cloth moistened with alcohol will restore its original appearance almost completely.

Precautions

- Avoid spraying liquids into the mechanism.
- Do not autoclave.
- Never use the *film spool* to lift or carry the dispenser. Use only the *carrying handle* for this purpose.
- If it proves necessary to lubricate certain mechanical parts, use only thick silicone grease, never oil, and be careful not to allow the grease to come in contact with the spools and drive belts.

6 SPECIFICATIONS

Materials of construction

External case: Ultem®.

Internal case: Stainless steel.

Paint: Epoxy-baked.

Dimensions and Weight

Height: 240 mm.

Width: 160 mm.

Depth: 235 mm.

Weight empty: 2.4 kg.

7 TROUBLESHOOTING

Symptom	Probable cause	Corrective action
<p>Refer to Figures 10 and 11 on the page 13 for the list of component parts.</p> <p>Membranes not dispensed correctly</p>		
<p>1. The film is not separated from the paper backing on the <i>plate</i> edge (the film is pulled by the backing).</p>	<p>Separate the film from the paper backing up to the separating bar. If the fault persists, the <i>film spool</i> driving belt is worn</p>	<p>Replace the driving belts and the <i>tensioning spring</i>.</p>
<p>2. The paper backing catches on the sprockets (slack in the backing between <i>drive roller</i> and paper spool).</p>	<p>The <i>film spool</i> driving belt is worn.</p>	<p>Replace the driving belts and the <i>tensioning spring</i>.</p>
<p>3. There is slack in the paper backing between the <i>plate</i> and the <i>drive roller</i>:</p>		
<p>■ The film is no longer separated from the backing at the <i>plate</i> edge.</p>	<p>The <i>film spool</i> driving belt is worn.</p>	<p>Replace the driving belts and the <i>tensioning spring</i>.</p>
<p>■ The film is separated from the backing at the <i>plate</i> edge.</p>	<p>The <i>tensioning spring</i> is not taut enough.</p>	<p>Replace the <i>tensioning spring</i> and the driving belts.</p>
<p>4. The <i>actuator</i> does not drive the <i>drive roller</i>:</p>		<p>Check whether the symptom persists after fully depressing the <i>pushbutton</i> all the way down against the stop.</p>
<p>■ The symptom persists, but disappears when the <i>actuator</i> is raised all the way against the stop.</p>	<p>The lever spring is no longer taut enough.</p>	<p>Replace the lever spring.</p>
<p>■ The symptom persists when the <i>actuator</i> is depressed then raised fully against the stop.</p>	<p>The latch springs are damaged.</p>	<p>Replace the latch springs. It is recommended that the <i>driving belts</i> and <i>tensioning spring</i> be replaced at the same time.</p>



Symptom	Probable cause	Corrective action
The <i>metal cover</i> is difficult to install or is not securely held in the housing.	The locking ball is out of adjustment.	Adjust the position of the locking ball with a screwdriver.

Removing a partially used band from the spools and reinstalling it after repair:

1. Rotate the *paper spool* counterclockwise by two turns to slacken the paper backing.
2. Remove the *paper spool clip*.
3. Remove the paper backing by pulling it straight out of the *paper spool*.
4. Take the paper backing off the sprockets on the *drive roller* and the *paper guide*.
5. To remove the film, repeat steps 1 to 3 above on the film spool.
6. Lay the film on the paper backing.
7. Cut the film and paper off at the fourth empty cell (the fourth cell ahead of the first membrane).
8. Repeat steps 11 to 16 (page 7–8) to reinstall the band. To position the backing paper (step 11), the vertical arrow must be located two sprocket holes ahead of a fold (the closest fold is located to the left of the arrowhead).

For additional information, contact your nearest Millipore office, specifying the catalogue number and serial number on the nameplate under the dispenser.



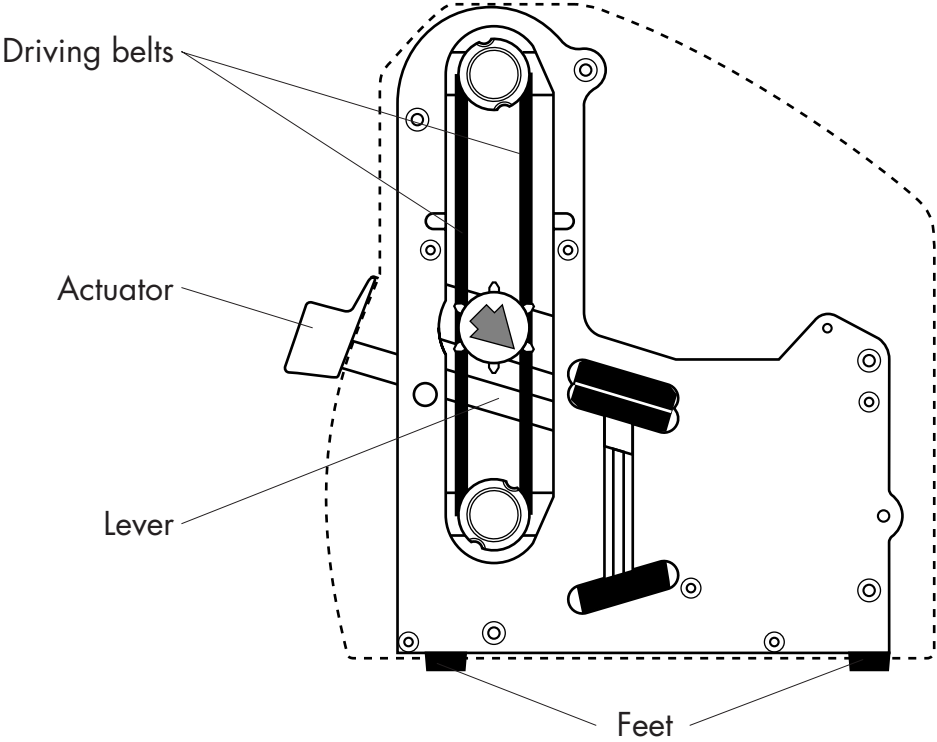

FIGURE 10

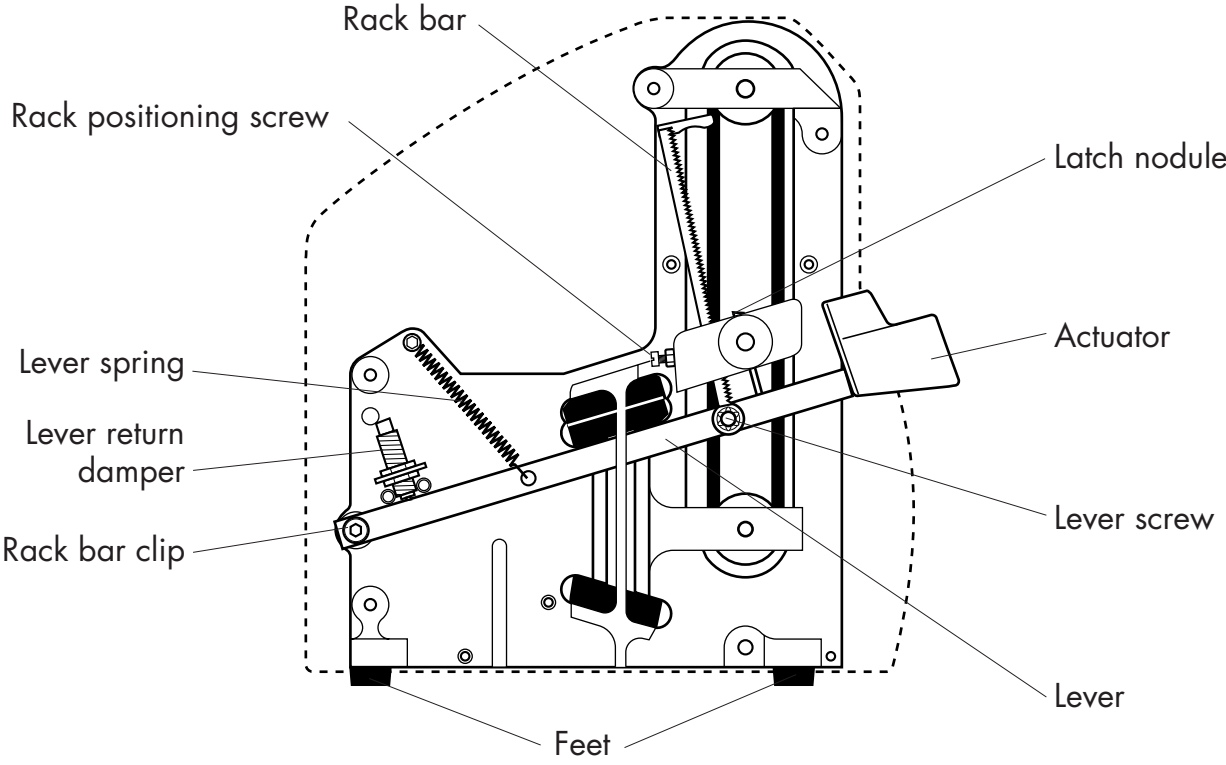

FIGURE 11



8 REPLACING WEAR PARTS

Driving Belts and Latch Springs

These parts should be replaced together.

Tools

- 2.5 mm and 3 mm Allen keys
- Latch spring installation tool
- Set of latch belts and springs
- Scissors or cutter
- Cloth and cleaning agent

Procedure

1. Unscrew the 6 socket head screws with the 2.5 mm Allen key and remove the inside cover (located on the side of the spools).
2. Remove the outside cover as follows:
 - Break the retaining tab located under the actuator with a screwdriver or other strong pointed object and remove the actuator.
 - Remove the two feet by **pushing** the internal shaft and pulling on the feet.
 - Unscrew the five socket head screws from the cover with the 3 mm Allen key.
 - Push the lever down against the stop and hold it there.
 - Remove the cover.
3. Cut the two drive belts.

Replacing the Latch Springs

4. Lift the latch and cut the two retaining springs.
5. Remove the latch.
6. Engage the spring installation tool on the *drive roller*.
7. Fit two new springs on the tool to place them in their grooves.
8. Remove the installation tool.
9. Lift the two springs and fit the latch in its housing.

.....

Replacing the Driving Belts

- 10.** Clean the spool grooves with a clean cloth slightly moistened with a cleaning agent (e.g. acetone).
- 11.** Set the two belts on a flat surface, one inside the other.
- 12.** Engage the larger belt (the outside one) on the *film spool* and *drive roller*.
- 13.** Move the belt along the spools, fitting it over the sprockets, until it is in the grooves.
- 14.** Engage the second, smaller belt on the *paper spool* and *drive roller*.
- 15.** Move the belt along the spools, fitting it over the sprockets, until it is in the grooves.
- 16.** Install the inside and outside covers by carrying out steps 1 and 2 of page 14 in reverse order.
- 17.** Check that the belts are correctly positioned by operating the *actuator* several times.

Tensioning Spring

The *tensioning spring* should always be replaced at the same time as the latch belts and springs.

Tools

- Adjustable wrench
- *Tensioning spring*

Procedure

- 1.** Unscrew the spring-nut and lock-nut located under the *plate*. Remove the two washers and the old spring.
- 2.** Install a new spring, the flat washer then the self-locking washer, the nut and the lock-nut.
- 3.** Check that the spring does not rub against the sides of the oblong hole.

.....

Lever Spring

Tools

- 2.5 mm Allen key
- 3 mm Allen key
- Lever spring

Procedure

1. Unscrew the 6 socket head screws with a 2.5 mm Allen key and remove the inside cover (located on the side of the spools).
2. Remove the outside cover as follows:
 - Break the retaining tab located under the actuator with a screwdriver or other strong pointed object and remove the actuator.
 - Remove the two feet by **pushing** the internal shaft and pulling on the feet.
 - Unscrew the five socket head screws from the cover with the 3 mm Allen key.
 - Push the lever down against the stop and hold it there.
 - Remove the cover.
3. The spring is then accessible and can be replaced without using any tools.
4. Install the inside and outside covers by carrying out steps 1 and 2 on in reverse order.

For additional information, contact your nearest Millipore office, specifying the catalogue number and serial number on the nameplate under the dispenser.

9 ORDERING INFORMATION

Ordering Information

Description	Catalogue No.
EZ-Pak membrane dispenser (Qty 1)	<u>EZDI SPO 01</u>
Kit of spare parts including: <ul style="list-style-type: none">- 3 actuators- 1 clip- 4 feet- 2 sets of latch springs- 2 sets of driving belts- 2.5 mm and 3 mm Allen keys- latch spring installation tool- latch- cover attaching screws- 2 tensioning springs	<u>EZDI KIT 01</u>
EZ-Pak Membranes (4 cartridges, each containing 150 membranes)	
EZ-Pak membranes, 0.45 µm, white, gridded, 47 mm diameter, Q 600	<u>MSP0 008 13</u>
EZ-Pak membranes, 0.45 µm, black, gridded, 47 mm diameter, Q 600	<u>MSP0 008 14</u>
EZ-Pak Membranes (150 membranes with 150 Microfil funnels)	
EZ-Pak membranes, 0.45 µm, white, gridded, diameter 47 mm, Q150 and 6 packets of 25 Microfil funnels, 100 ml	<u>MZHA WG1 01</u>
EZ-Pak membranes, 0.45 µm, white, gridded, diameter 47 mm, Q150 and 5 packets of 30 Microfil funnels, 250 ml	<u>MZHA WG2 51</u>
EZ-Pak membranes, 0.45 µm, black, gridded, diameter 47 mm, Q150 and 6 packets of 25 Microfil funnels, 100 ml	<u>MZHA BG1 01</u>
EZ-Pak membranes, 0.45 µm, black, gridded, diameter 47 mm, Q150 and 5 packets of 30 Microfil funnels, 250 ml	<u>MZHA BG2 51</u>

The range of available membranes is growing rapidly. Contact your nearest Millipore office for further information on the other types of EZ-Pak membranes or to place an order.

10 WARRANTY

Millipore warrants its products against defects in manufacturing and workmanship for a period of one (1) year from the date of delivery, provided that they have been used under the conditions described in this manual.

Millipore offers no other warranty neither explicit nor implicit, in particular no warranty of merchantability or fitness for a particular purpose. The terms of this warranty, as well as information, characteristics and descriptions of Millipore products shown on brochures and catalogues published by the Company may not be modified without express authorization signed by a duly qualified Millipore representative. Any written or oral interpretation not in accordance with this warranty or to the said publications shall be considered null and void.

In case of non-respect of the terms of the above-mentioned warranty, Millipore's sole obligation shall be to repair or replace, at its discretion, all or part of a product found to be defective during the period of warranty, due to defects in workmanship or manufacturing, on condition that the customer notifies the fault immediately.

The present service obligation cannot be considered as not having been fulfilled if Millipore has demonstrated its good faith in repairing or replacing any defective Millipore product or part.

Millipore cannot be held responsible for prejudice due to non-operation or damage to property where its products could have been the cause, nor consequently be required to award indirect damages.

The terms of this warranty do not affect the buyer's statutory rights.

Millipore Worldwide – Millipore dans le monde – Millipore weltweit – Millipore en el mundo – Millipore nel mondo – ミリポア事務所所在地

AUSTRALIA

Millipore Australia Pty. Ltd.
A.C.N. 001 239 818
Private Bag No. 18
87-89 Mars Road
Lane Cove, N.S.W.2066
Tel. Toll-Free: (008) 222-111
In Sydney Area (02) 428-7333
FAX (02) 427-0611

AUSTRIA, CENTRAL EUROPE, C.I.S., AFRICA, MIDDLE EAST AND GULF

Millipore Ges.m.b.H.
Hiefzinger Hauptstraße 145
A-1130 Wien, Austria
Tel. (43) 1 877 8926
Telex 131464 miliv a
FAX (43) 1 877 1654

BALTIC REPUBLICS

Millipore Oy
Lanttikatu 2
FIN-02770 Espoo
Finland
Tel. 358-0-804 51 10
FAX 358-0-859 66 16

BELGIUM AND LUXEMBURG

Millipore S.A.-N.V.
Rue de la Fusée 60
Raketstraat 60
B-1130 Bruxelles-Brussels
Tel. (02) 726.88.40
FAX (02) 726.98.84

BRAZIL

Millipore Indústria
e Comércio Ltda.
Rua Prof. Campos
de Oliveira, 430
CEP 04675
São Paulo-SP
Tel. (011) 548-7011
Telex (011) 57751 MILY BR
FAX (011) 548-7923

CANADA

Millipore (Canada) Ltd.
36 Antares Drive/
Suite 700/
Nepean, Ontario, K2E 7W5
Tel. Toll-Free 1-800 Millipore
FAX (613) 225-9366

CHINA

PEOPLE'S REPUBLIC OF
Millipore China Ltd.
Room 302 Office Bldg.
Asia Jinjiang Hotel
8 Xinzhong Xijie Gongti
Bei Lu, Beijing (100027)
Tel. (86-1) 5008063
FAX (86-1) 5007372

Millipore China Ltd.
Room 615
China Hotel Office Tower
Linhua Lu
Guangzhou
Postal Code 510015
Tel. (86) 20-686217

CHINA

PEOPLE'S REPUBLIC OF
Millipore China Ltd.
Suite 2806, Union Building
100 Yan An Road (E)
Shanghai 200002, P.R.C.
Tel. (86) 21-3737256
FAX (86) 21-3200236

CZECH REPUBLIC

Millipore spol.s.r.o
Obchodní Zastoupení
Ricanova 21
CZ-169 00 Praha 6
Tel. 42-2 205 13841
FAX 42-2-235 2375

DENMARK

Millipore A/S
Baldersbuen 46
DK-2640 Hedehusene
Tel. 46 59 00 23
FAX 46 59 13 14

FINLAND

Millipore Oy
Lanttikatu 2
FIN-02770 Espoo
Tel. (90) 804 51 10
FAX (90) 859 66 16

FRANCE

Millipore S.A.
BP 307
F-78054 Saint-Quentin
Yvelines Cedex
Tel. 01.30.12.70.00
Telex 698 371 F
FAX 01.30.12.71.80

GERMANY

Millipore GmbH
Hauptstraße 87
D-65760 Eschbom
Tel. 49-6196494 0
Telex 40 72 704 mil d
FAX 49-6196 439 01

HONG KONG

Millipore China Ltd.
Millipore Asia Ltd.
1406 Cityplaza 4
12 Taikoo Wan Road
Hong Kong
Tel. (852)-2-803 9111
Telex 331 40 MWBHK HX
FAX (852)-2-513 0313

HUNGARY

Millipore kft
Andor u. 47-49
H-1119 Budapest
Tel. (1) 166 86 74
(1) 185 11 22
Telex 22 30 57
FAX (1) 185 32 36

INDIA

Millipore (India) Pvt. Ltd.
50-A, 2nd Phase,
Ring Road Peenya
Bangalore 560 058
Tel. 91 (808) 394657, 396320
Telex 845-5089 MLPR IN
Cable: Millipore
FAX 91 (808) 396345

ITALY

Millipore S.p.A.
Via B. Buozzi, 4
I-20090 Vimodrone MI
Tel. (02) 25078.1
FAX (02) 2650324

Millipore S.p.A.
Via D. Sansotta 100
I-00144 Roma
Tel. (06) 5203600
FAX (06) 5295735

JAPAN

Nihon Millipore Ltd.
Dai 5 Koike Bldg. 3-12
Kitashinagawa 1-Chome
Shinagawa-Ku
Tokyo 140
Tel. (03) 3474-9111
Telex 24948 MILLIPOR J
FAX (03) 3474-9130

KOREA

Millipore Korea Ltd.
13F, Yusing Bldg.
706-25, Yoksam-Dong
Kangnam-Ku, Seoul 135-080
Tel. (82-2) 5386211
FAX (82-2) 5636253

MALAYSIA

Millipore Asia Ltd.
Malaysia Branch
B4 - 05/06, P.J. Industrial Park
Section 13 Jalan Kemajuan
46200 Petaling Jaya, Selangor
Tel. (603) 757 1322
FAX (603) 757 1711

MEXICO

Millipore S.A. de C.V.
Avenida Ingenieros Militares 85-PB
México 11230 D.F.
Tel. (525) 576-96-88
FAX (525) 576-87-06

THE NETHERLANDS

Millipore B.V.
Penningweg 33
Postbus 166
NL-4870 AD Etten-Leur (N.B.)
Tel. (076) 5022000
Telex 54 840 milwa nl
FAX (076) 5022436

NORWAY

Millipore AS
Postboks 39, Simensbraten
N-1107 Oslo
Tel. (47) 22 67 82 53
FAX (47) 22 68 53 15

POLAND

Millipore Sp.z.o.o.
Oddział w Warszawie
Ul. Jasnodworska 7
PL-01-745 Warszawa
Tel. 22 669 12-25/663 70 31
Telex 825 422
FAX 22 663 70 33

PUERTO RICO

Millipore Corporation
Puerto Rico Branch
P.O. Box 11977
Cidra, Puerto Rico 00739
Tel. (809) 273-8495
FAX (809) 747-8449

SINGAPORE

Millipore Asia Ltd.
Singapore Branch
#07-01/02 Jumbo Industrial Bldg.
19 Kim Keat Road
Singapore 328804
Tel. (65) 253-2733
FAX (65) 254-4056

SPAIN AND PORTUGAL

Millipore Ibérica, S.A.
Avda. del Llano Castellano, 13-3°
E-28034 Madrid
Tel. 91-729 03 00
FAX 91-729 29 09

Millipore Ibérica, S.A.
Entenza, 28°
E-08015 Barcelona
Tel. 93-325 96 16
FAX 93-325 98 96

SWEDEN

Millipore AB
Box 7090
S-172 07 Sundbyberg
Tel. 08-628 69 60
FAX 08-628 64 57

SWITZERLAND

Millipore AG
Chriesbaumstrasse 6
CH-8604 Volketswil
Tel. (01) 908 30 60
Telex 82 94 08 MLAG CH
FAX (01) 908 30 80

Millipore SA
Avenue de Maillefer 43
CH-1052 Le Mont-sur-Lausanne
Tel. (021) 648 51 18
FAX (021) 648 51 37

TAIWAN

Millipore Asia Ltd.
Unit #707, 7/th, fl
136 Jen-Ai Road, Sec. 3
Taipei Tawai R.O.C.
Tel. (886-2) 7001742
FAX (886-2) 7553267

U.K. AND IRELAND

Millipore (U.K.) Ltd.
"The Boulevard"
Blackmoor Lane Watford,
Hertfordshire WD1 8YW
Tel. (01923) 816375
Telex 24191 milpor g
FAX (01923) 818297

U.S.A.

Millipore Corporation
P.O. Box 255
Bedford, MA 01730
Tel. Toll-Free
(including Massachusetts)
1-800 Millipore
or 1-800-645-5476
In Western States,
Alaska & Hawaii
800-632-2708
In Puerto Rico (809) 273-8495

IN ALL OTHER COUNTRIES

Millipore Intertech
80 Ashby Road
Bedford, MA 01730
U.S.A.
Tel. 1-617 275 9200
FAX 1-617 275 5550