

NovAseptic® Mixer Tank Plate, HS T60 ATEX

Product Description

NovAseptic® mixers offer a complete solution for mixing throughout the process line and are designed for a wide variety of mixing applications in the pharmaceutical and biotechnology industries.

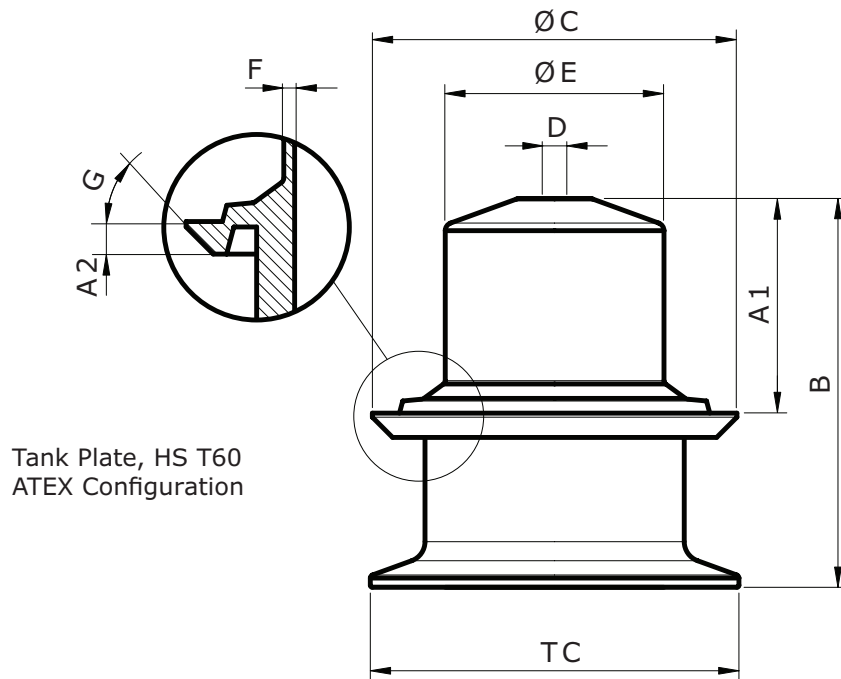

Nominal Dimensions in mm (in.)

AX30-###*	A1	A2	B	C	D	E	F	G	TTC	Compatible Mixer
AX30-009	53 (2.09)	6 (0.24)	96 (3.78)	90 (3.54)	M8x1	54 (2.13)	2 (0.08)	45°	91 (3.58)	HS T60 ATEX

*Note: NovAseptic® Gauge 1 (G91-###) and NovAseptic® Gauge 2 (G92-###) are mandatory for tank plate deformation check and shall be ordered separately

Specifications

Net Weight (approximate)	
Tank Plate	AX 30-009
Weight kg (lb)	0.9 (2.0)

Welding Diameter	
Tank Plate	AX 30-009
Diameter mm (in)	Ø90 (03.54)

Material		
Bar	Stainless steel in compliance with	
Material Code	316L	EN 1.4435
Technical Requirements	ASME® SA-479	EN 10272

Additional Information	
Surface Roughness	Surface Ra ≤ 0.38 µm (15 µin)
Surface Treatment	Liquid contact surface, manually polished
Design Temperature	-80 to 135°C (-112 to 275°F)
Design Pressure	-1 to 10 bar(g) (-14.5 to 145 psi(g))
Note	The assembled NovAseptic® Mixer may have different design temperature and/or pressure limits. The weakest component in the assembled product determines the maximum temperature and pressure limits.
Labeling	Each tank plate is individually labeled for full traceability and heat number according to our QA routines.
Packaging	The tank plate is packaged in a closed box.
Quality Control	Our Quality Assurance System guarantees the control and traceability at all stages of the manufacturing.
Liquid viscosity	1 to 800 cP max
Requirements	The tank plate is designed to meet requirements for USA, ASME® VIII Div 2. Stresses in tank plate due to internal pressure have been analysed by FEM. The NovAseptic® Tank plate is not in the scope of the PED directive 2014/68/UE. However they have been designed and evaluated for assembly by welding at a bottom of a vessel with a max allowable pressure of 10 bar and a max allowable temperature of 200°C

The tank plate must be used with the appropriate ATEX HS drive unit, rotor and stator

Technical Assistance

For more information, please visit SigmaAldrich.com
for up-to-date worldwide contact information

